



**College of Engineering & Technology**

**University of Sargodha**

**Department of Electrical Engineering Technology**

**ET-314**

**Telecommunication Technology**

**Lecture 08**

***Angle Modulation***

***Instructor: Engr. Erum Rehman***

# Angle Modulation (Phase & Frequency Modulation)

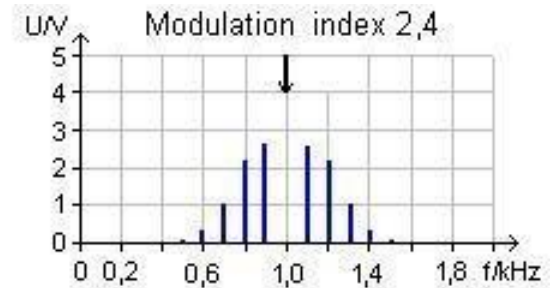
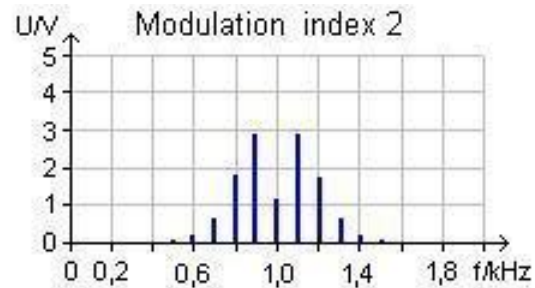
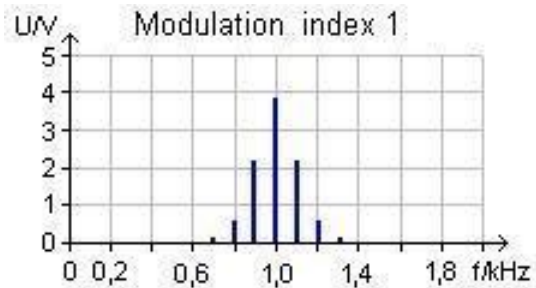

# Amplitude, Frequency and Phase Modulation

Amplitude Modulation



Phase Modulation

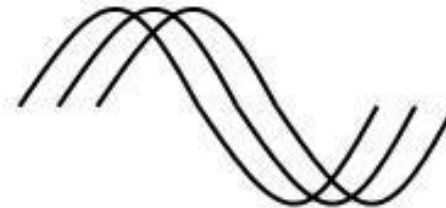

Frequency Modulation

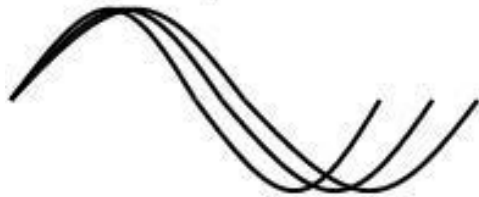

**With few exceptions,  
Phase Modulation  
(PM) is used  
primarily in digital  
communication**

## Why Use a Carrier Signal?

Carrier signals are used for two reasons:

(1) To **reduce the wavelength** for efficient transmission and reception (the optimum antenna size is  $\frac{1}{4}$  of a wavelength). A typical audio frequency of 3000 Hz has a wavelength of 100 m and would need an effective antenna length of 25 m! By comparison, a typical FM carrier is 100 MHz, with a wavelength of 3 meters, and would have an 80 cm long antenna (that is 31.5 inches long).

(2) To allow simultaneous use of the same channel, called **multiplexing**. Each unique message signal has a different assigned carrier frequency (*e.g.*, radio stations) and share the same channel. The telephone company invented modulation to allow phone conversations to be transmitted over common phone lines. Mandated by the FCC.

# Illustrating AM, PM and FM

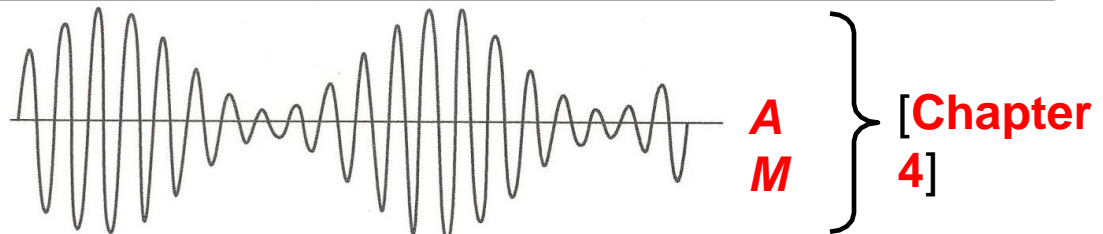
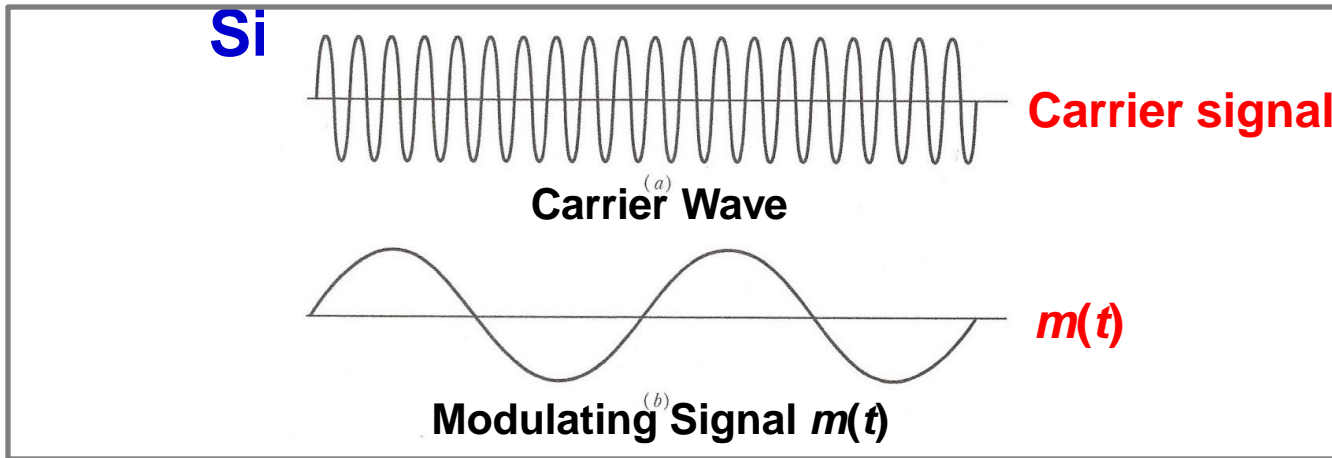

**AM Modulated Signal** <sup>(c)</sup>

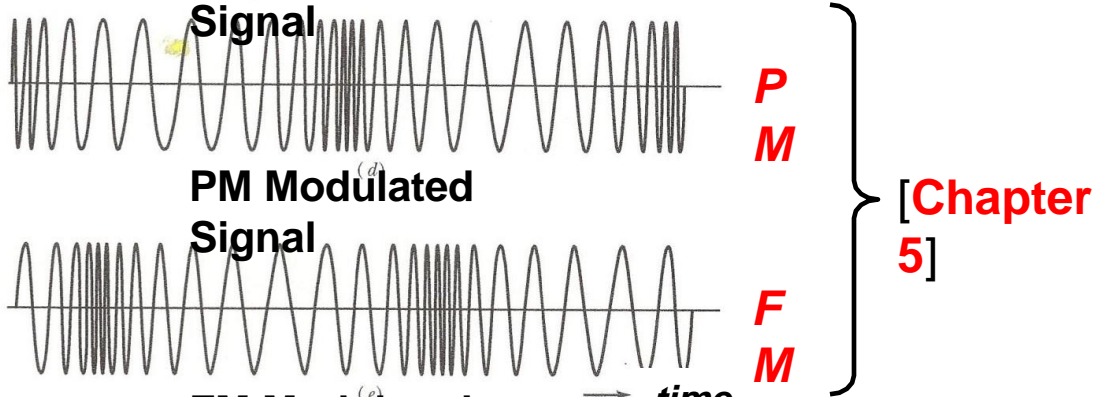

**FM Modulated Signal** <sup>(e)</sup> → **time**

**Lathi &  
Ding;  
Page 252-  
292**

# Phase-Frequency Relationship When Frequency is Constant

$$\varphi(t) = A\cos(\theta(t))$$

$\theta(t)$  is generalized angle

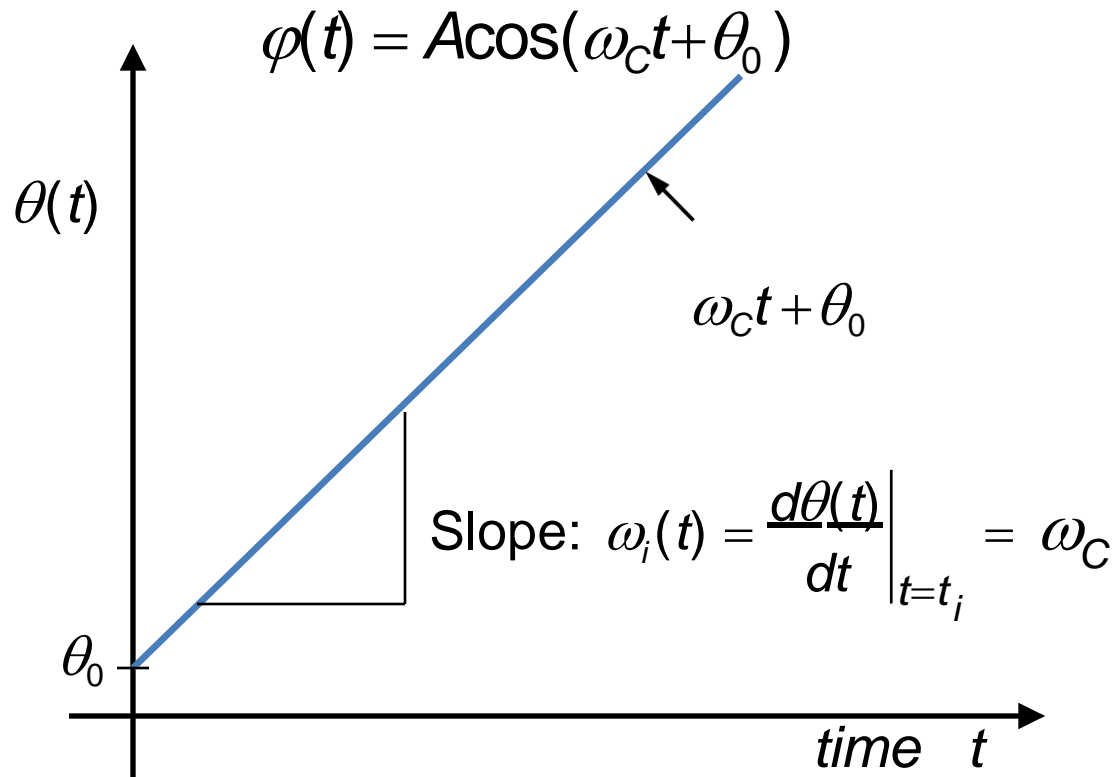

# Concept of Instantaneous Frequency

Angl  
Modulatio  
n

$$\varphi(t) = A \cos(\theta(t))$$

↑  
 $\theta(t)$  is generalized angle

$$\varphi(t) = A \cos(\omega_c t + \theta_0)$$

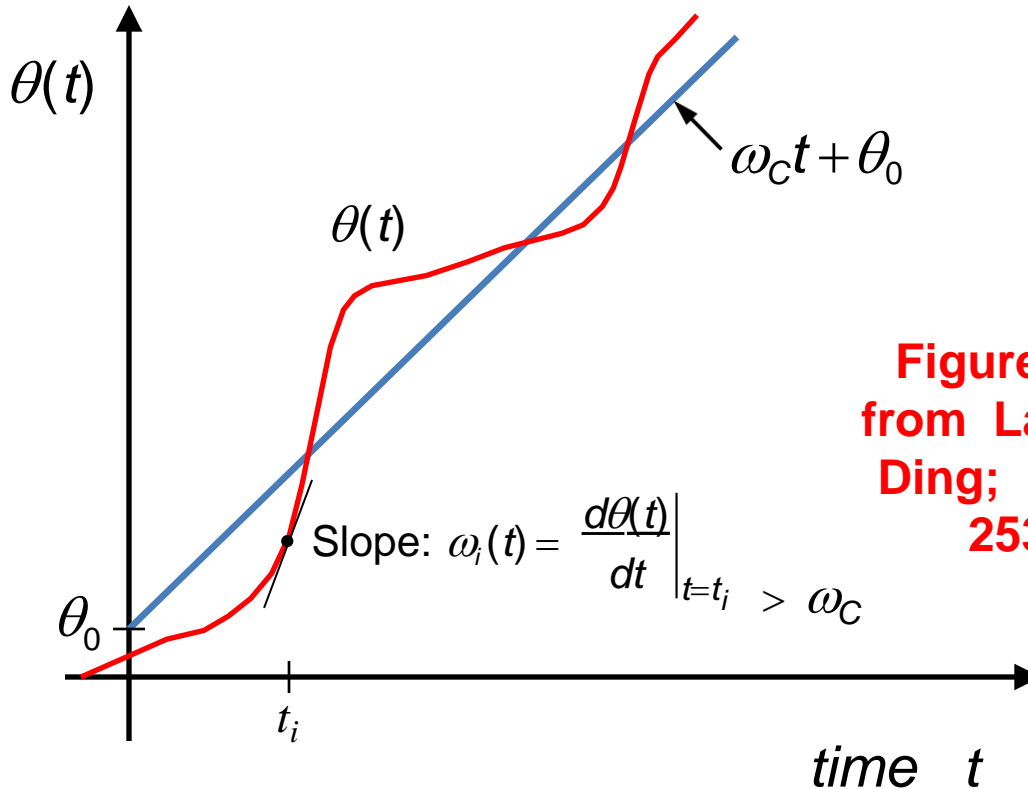
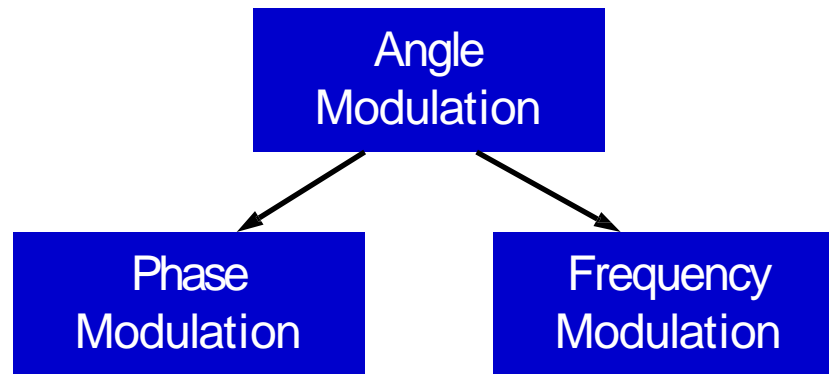

Figure 5.1  
from Lathi &  
Ding; Page  
253

# Angle Modulation Gives PM and FM

$$\omega_i(t) = \left. \frac{d\theta(t)}{dt} \right|_{t=t_i} \quad \text{and} \quad \theta(t) = \int_{-\infty}^t \omega_i(\alpha) d\alpha$$



Frequency modulation and phase modulation are closely related!



# Comparing Frequency Modulation to Phase Modulation

#	Frequency Modulation (FM)	Phase Modulation (PM)
1	Frequency deviation is proportional to modulating signal $m(t)$	Phase deviation is proportional to modulating signal $m(t)$
2	Noise immunity is superior to PM (and of course AM)	Noise immunity better than AM but not FM
3	Signal-to-noise ratio (SNR) is better than in PM	Signal-to-noise ratio (SNR) is not as good as in FM
4	FM is widely used for commercial broadcast radio (88 MHz to 108 MHz)	PM is primarily for some mobile radio services
5	Modulation index is proportional to modulating signal $m(t)$ as well as modulating frequency $f_m$	Modulation index is proportional to modulating signal $m(t)$

# Phase Modulation

$$\theta(t) = \omega_c t + \theta_0 + k_p m(t) \quad \text{Generally we let } \theta_0 = 0.$$

Let  $\theta_0 = 0$

$$\varphi_{PM}(t) = A \cos(\omega_c t + k_p m(t))$$

**Equation  
(5.3b) Lathi  
& Ding;  
Page 254**

The instantaneous angular frequency (in radians/second) is

$$\omega_i(t) = \frac{d\theta(t)}{dt} = \omega_c + k_p \frac{m(t)}{dt} = \omega_c + k_p \dot{m}(t)$$

In phase modulation (PM) the instantaneous angular frequency  $\omega_i$  varies linearly with the derivative of the message signal  $m(t)$  (denoted here by  $\dot{m}(t)$ ).

$k_p$  is phase-deviation (sensitivity) constant. Units: radians/volt  
[Actually in radians/unit of the parameter  $m(t)$ .]

# Frequency Modulation (FM)

But in frequency modulation the instantaneous angular frequency  $\omega_i$  varies linearly with the modulating signal  $m(t)$ ,

$$\omega_i = \omega_c + k_f m(t)$$

$$\theta(t) = \int_{-\infty}^t (\omega_c + k_f m(\alpha)) d\alpha = \omega_c t + k_f \int_{-\infty}^t m(\alpha) d\alpha$$

$k_f$  is frequency-deviation (sensitivity) constant. Units: radians/volt-sec.

Then

$$\varphi_{FM}(t) = A \cos \left( \omega_c t + k_f \int_{-\infty}^t m(\alpha) d\alpha \right)$$

**Equation  
(5.5) Lathi  
& Ding;  
Page 254**

FM and PM are very much related to each other.



In PM the angle is directly proportional to  $m(t)$ .

In FM the angle is directly proportional to the integral of  $m(t)$ , i.e.,  $\int m(t) dt$

# Summary

Definition: Instantaneous frequency is

$$\omega_i(t) = \frac{d\theta(t)}{dt}$$

	Phase Modulation	Frequency Modulation
Angle	$\theta(t) = \omega_C t + k_p m(t)$ 	$\theta(t) = \omega_C t + k_f \int_{-\infty}^t m(\alpha) d\alpha$
Frequency	$\omega_i = \omega_C + k_p \frac{dm(t)}{dt}$	$\omega_i = \omega_C + k_f m(t)$ 

In phase modulation  $m(t)$  drives the variation of phase  $\theta$ .

In frequency modulation  $m(t)$  drives the variation of frequency  $f$ .

# A Pictorial Way to View the Generation of FM and PM

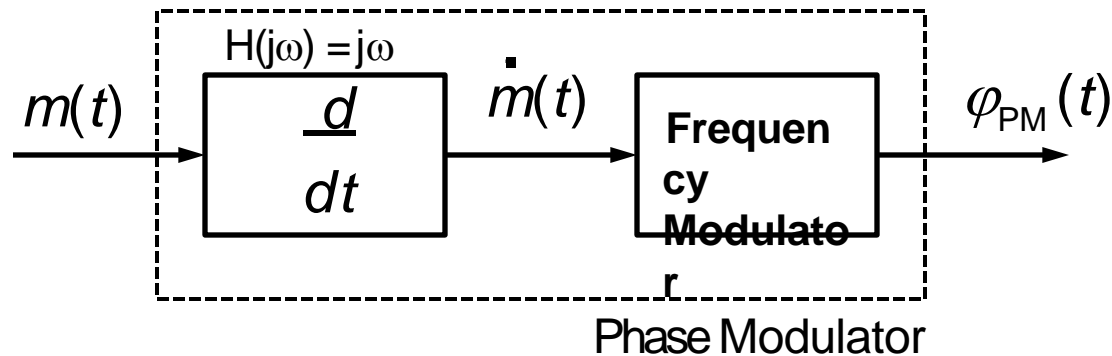
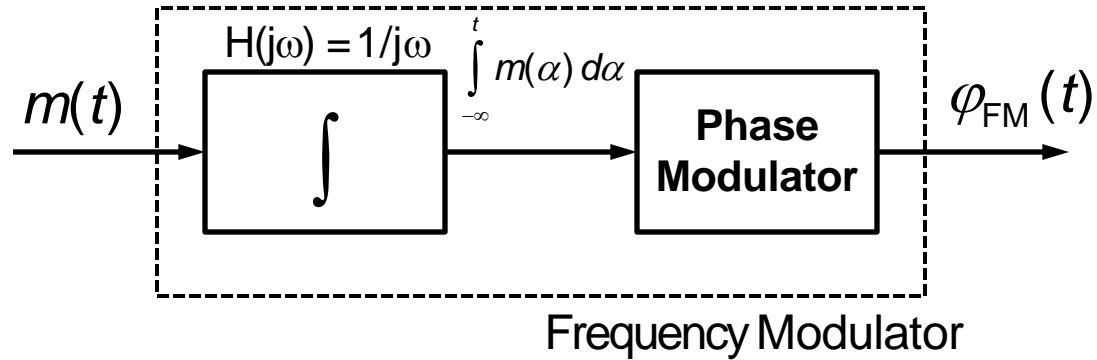

We require that  $H(j\omega)$  be a reversible (or invertible) operation so that  $m(t)$  is recoverable.

# Equations for FM Wave with Single Tone Modulation

Carrier signal

$$A_c \cos(\omega_c t)$$

Carrier frequency

$$\omega_c = 2\pi f_c$$

Modulating wave  $m(t)$

$$A_m \cos(\omega_m t) \quad \text{A single tone frequency}$$

Modulating frequency

$$\omega_m = 2\pi f_m \quad (\text{radians/sec})$$

Deviation sensitivity

$$k_f$$

Frequency deviation

$$\Delta f = k_f A_m = k_f \left( \frac{m_{\max} - m_{\min}}{2 \cdot 2\pi} \right)$$

Modulation Index

$$\beta = \frac{\Delta f}{f_m}$$

Instantaneous frequency

$$f_i = f_c + k_f A_m \cos(\omega_m t) = f_c + \Delta f \cos(\omega_m t)$$

Remember

$$\varphi_{FM}(t) = A_c \left[ \cos \left( \omega_c t + k_f \left( \int_{-\infty}^t m(\alpha) d\alpha \right) \right) \right], \text{ generally}$$

Modulated wave

$$\varphi_{FM}(t) = A_c \left[ \cos \left( \omega_c t + \frac{k_f A_m}{f_m} \sin(\omega_m t) \right) \right]$$

or

$$\varphi_{FM}(t) = A_c \left[ \cos(\omega_c t + \beta \sin(\omega_m t)) \right]$$

**Handout**

# Generalized Angle Modulation

The first block can be any linear time-invariant (LTI) operator – it need only be invertible so that we can recover  $m(t)$ . In general, we have

Note:  $h(t)$  is the unit impulse response

$$\varphi_{GAM}(t) = A \cos \left[ \omega_c t + \int_{-\infty}^t m(\alpha) h(t - \alpha) d\alpha \right]$$

Phase Modulation:  $h(t) = k_p \delta(t)$ ,

Frequency Modulation:  $h(t) = k_f u(t)$

We shall focus more on Frequency Modulation in this course and less on Phase Modulation.

## Average Power of a FM or PM Wave

The amplitude  $A$  is constant in a phase modulated or a frequency modulated signal. RF power does not depend upon the frequency or the phase of the waveform.

$$\varphi_{FM \text{ or } PM}(t) = A \cos [\omega_c t + f(k, m(t))]$$

$$\text{Average Power} = \frac{A^2}{2} \text{ (always)}$$

**This is a result of FM and PM signals being constant amplitude.**



## Comparison of FM (or PM) to AM

#	Frequency Modulation (FM)	Amplitude Modulation (AM)
1	FM receivers have better noise immunity	AM receivers are very susceptible to noise
2	Noise immunity can be improved by increasing the frequency deviation	No such option exists in AM
3	Bandwidth requirement is greater and depends upon modulation index	Bandwidth is less than FM or PM and doesn't depend upon a modulation index
4	FM (or PM) transmitters and receivers are more complex than for AM	AM transmitters and receivers are less complex than for FM (or PM)
5	All transmitted power is useful so FM is very efficient	Power is wasted in transmitting the carrier and double sidebands in DSB (but DSB-SC addresses this)

# Phasor Interpretation of AM DSB with Carrier

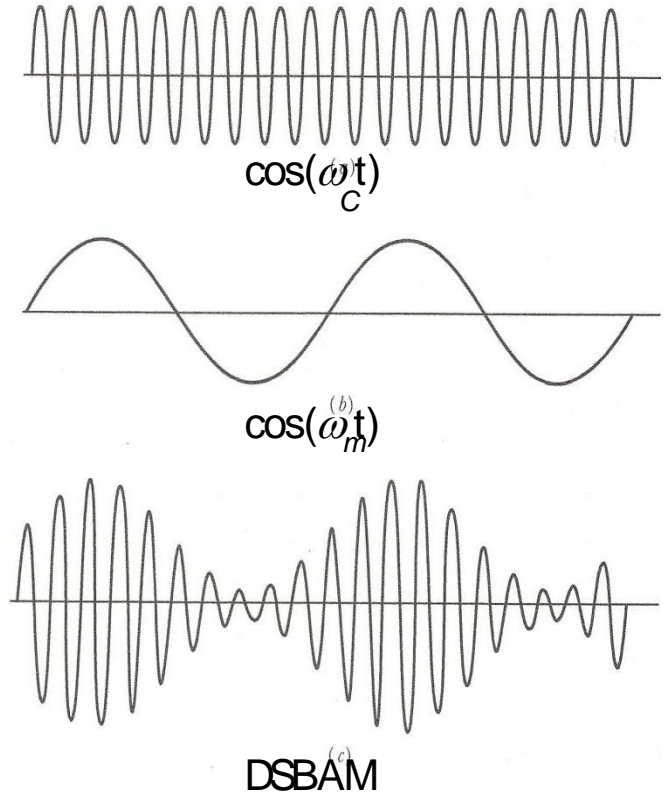
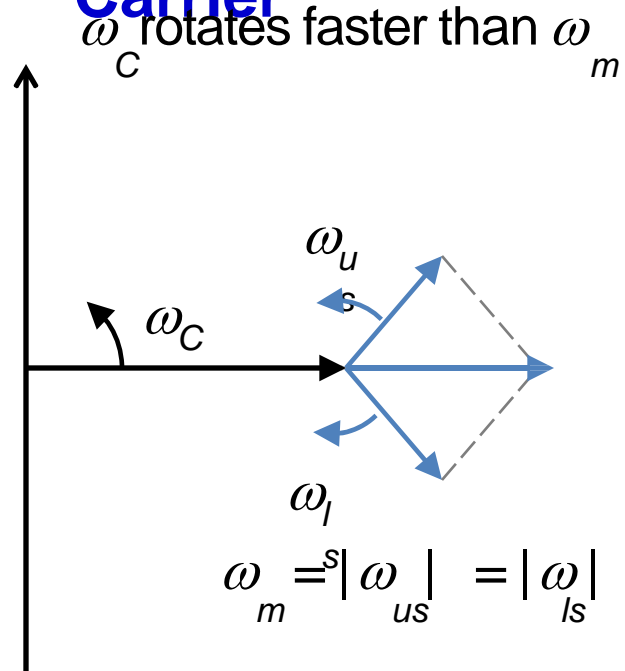

Spectrum:

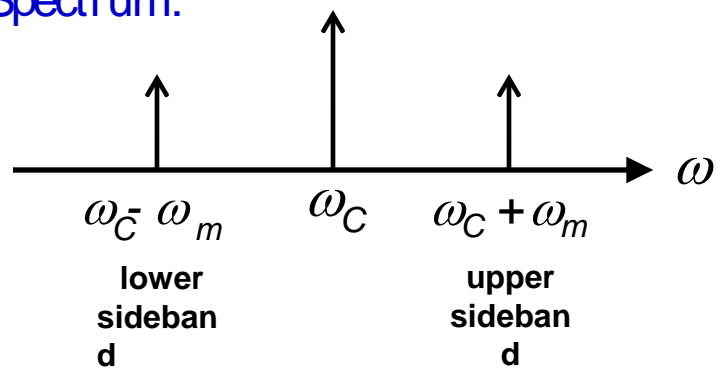

# Phasor Interpretation of AM DSB with Carrier (continued)

$V_{us}$  = Voltage of upper sideband phasor

$V_{ls}$  = Voltage of lower sideband phasor

$V_c$  = Voltage of the carrier

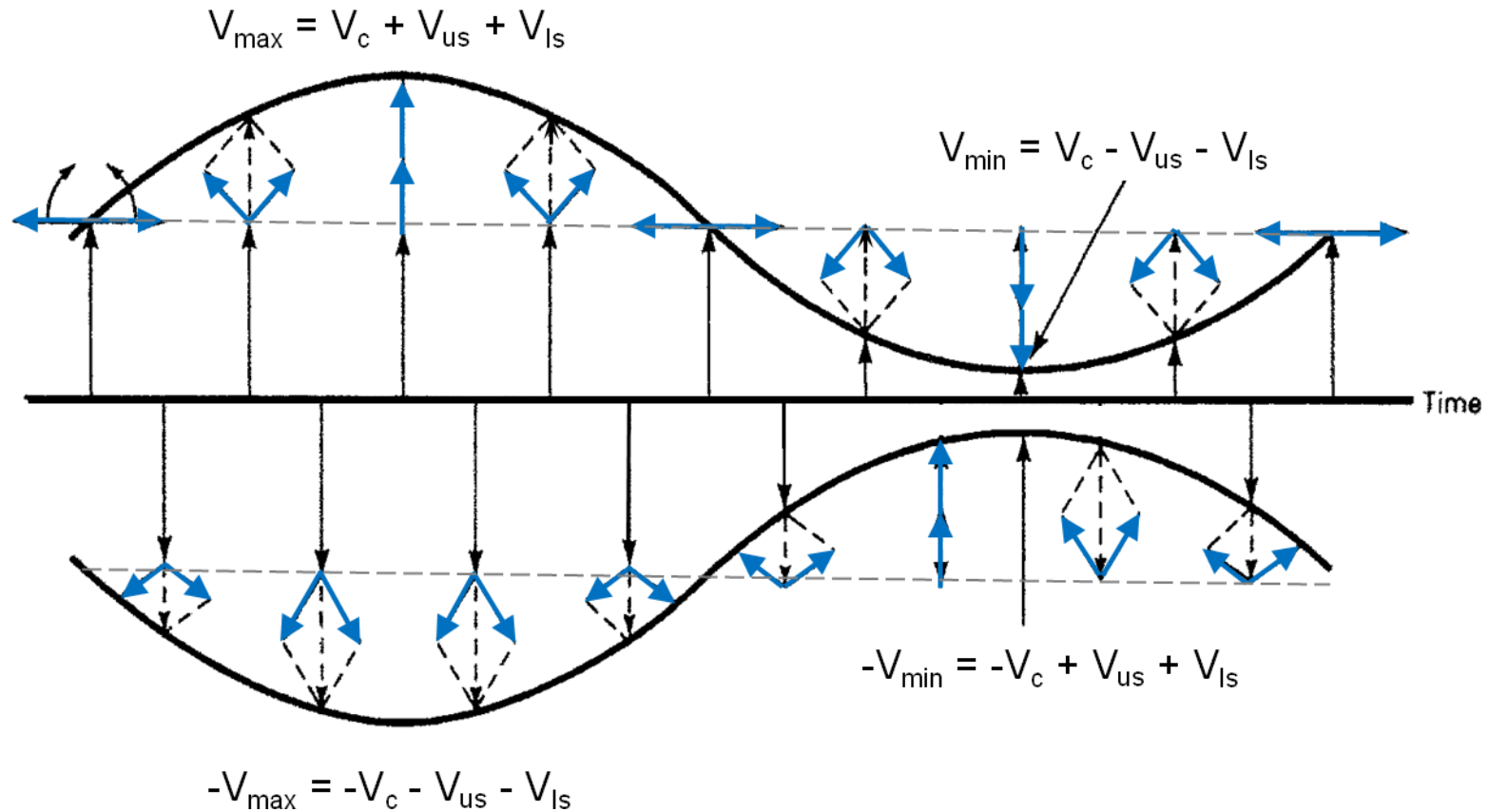

## Example 5.1 in Lathi and Ding (pp.

256-257)

Sketch FM and PM waveforms for the modulating signal  $m(t)$ . The constants  $k_f$  and  $k_p$  are  $2\pi \times 10^5$  and  $10\pi$ , respectively. Carrier frequency  $f_c = 100$  MHz.

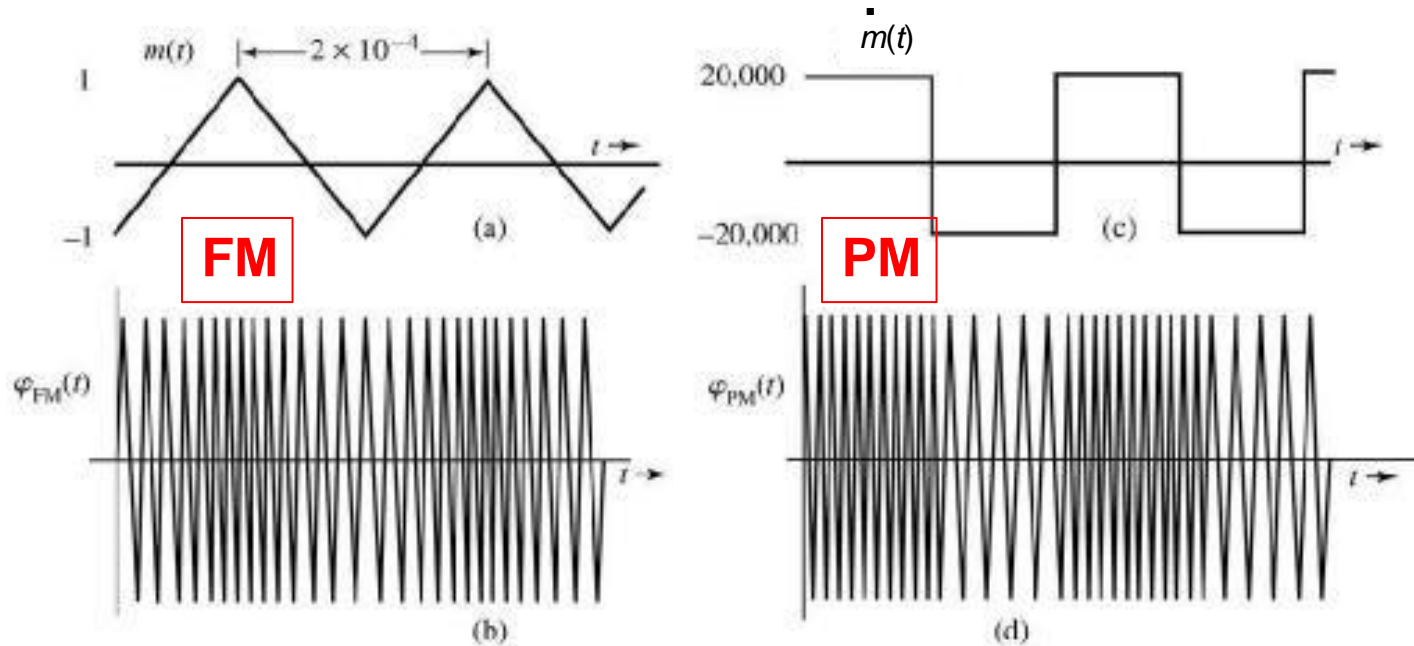

$$f_i = f_c + \frac{k_f}{2\pi} m(t) = 1 \times 10^8 + 1 \times 10^5 \cdot m(t);$$

$$m_{\min} = -1 \text{ and } m_{\max} = 1$$

$$(f_i)_{\min} = 10^8 + 10^5(-1) = 99.9 \text{ MHz,}$$

$$(f_i)_{\max} = 10^8 + 10^5(+1) = 100.1 \text{ MHz}$$

$$f_i = f_c + \frac{k_p}{2\pi} \dot{m}(t) = 1 \times 10^8 + 5 \cdot \dot{m}(t);$$

$$\dot{m}_{\min} = -20,000 \text{ and } \dot{m}_{\max} = 20,000$$

$$(f_i)_{\min} = 10^8 + 5(-20,000) = 99.9 \text{ MHz,}$$

$$(f_i)_{\max} = 10^8 + 5(+20,000) = 100.1 \text{ MHz}$$

## Example 5.2 in Lathi and Ding (pp. 257-259)

Sketch FM and PM waveforms for the modulating signal  $m(t)$ . The constants  $k_f$  and  $k_p$  are  $2\pi \times 10^5$  and  $\pi/2$ , respectively. Carrier frequency  $f_c = 100\text{MHz}$ .

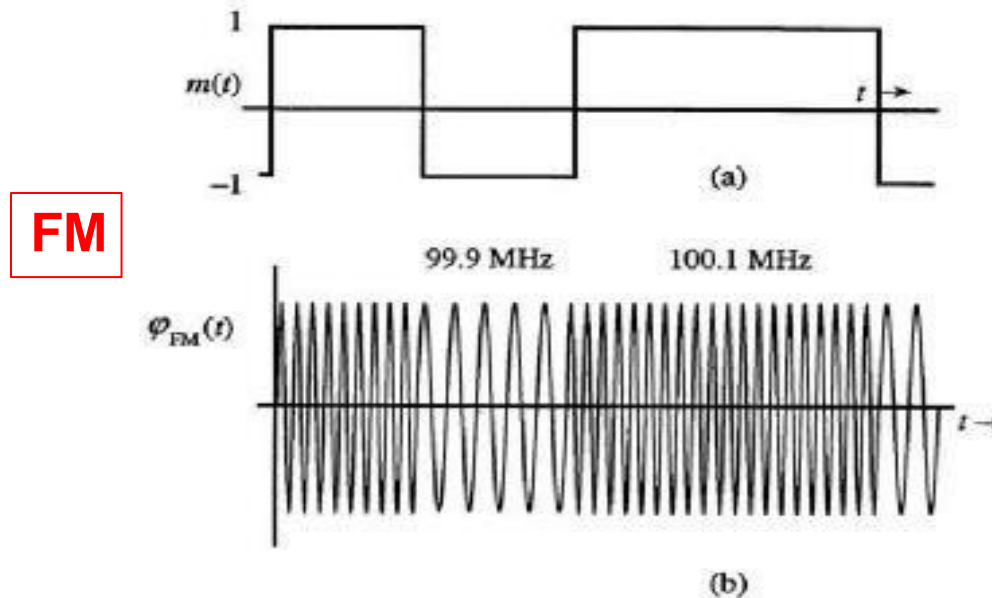

$$f_i = f_c + \frac{k_f}{2\pi} m(t) = 1 \times 10^8 + 1 \times 10^5 m(t)$$

Since  $m(t)$  switches from +1 to -1 and vice versa, the FM wave Frequency switches between 99.9 MHz and 100.1 MHz. This is called **Frequency Shift Keying (FSK)** and is a digital format.

## Example 5.2 in Lathi and Ding (pp. 257-259) – continued

Sketch FM and PM waveforms for the modulating signal  $m(t)$ . The constants  $k_f$  and  $k_p$  are  $2\pi \times 10^5$  and  $\pi/2$ , respectively. Carrier frequency  $f_c = 100$  MHz.

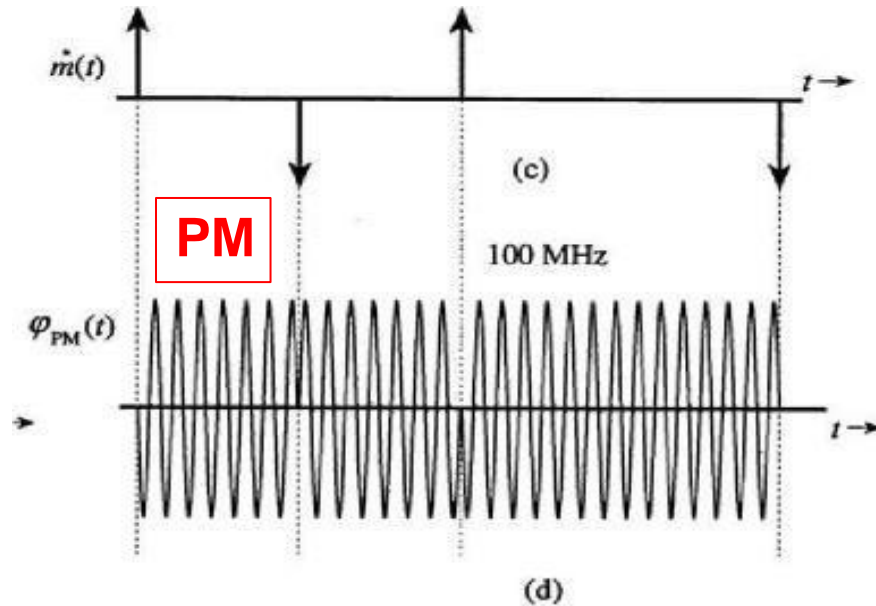

$$f_i = f_c + \frac{k_p}{2\pi} m(t) = 1 \times 10^8 + \frac{1}{4} m(t)$$

This is carrier PM by a digital signal – it is **Phase Shift Keying (PSK)** because digital data is represented by phase of the carrier wave.

$$\varphi_{PM}(t) = A \cos \left[ \omega_c t + k_p m(t) \right] = A \cos \left[ \omega_c t + \frac{\pi}{2} m(t) \right]$$

$$\varphi_{PM}(t) = A \sin(\omega_c t) \quad \text{when } m(t) = -1$$

$$\varphi_{PM}(t) = -A \sin(\omega_c t) \quad \text{when } m(t) = 1$$

Lathi & Ding;  
Page 258

# Case I – Narrowband FM (NBFM)

There are two approximations for FM:

▲ Narrowband approximation (NBFM)

▲ Wideband approximation (WBFM)

Lathi & Ding;  
Page 260

**NBFM:** 
$$\varphi_{\text{FM}}(t) = A \cos \left( \omega_c t + k_f \int_{-\infty}^t m(\alpha) d\alpha \right)$$

$$\beta = \frac{\Delta f}{f_m} = \frac{\Delta f}{B}$$

If  $\left| k_f \int_{-\infty}^t m(\alpha) d\alpha \right| \ll 1$ , we have NBFM.

$$\text{Let } k_f \int_{-\infty}^t m(\alpha) d\alpha \approx k_f \sin(\omega_m t),$$

Then bandwidth  $B_{\text{FM}} \approx 2 f_m$

NBPM requires  $\beta \ll 1$  radian  
(typically less than 0.2 radian)

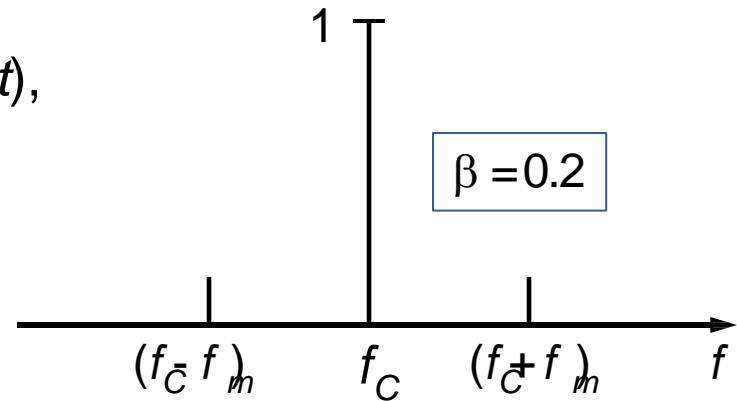

# Narrowband FM (NBFM) Equation

Start with design equation for tone frequency  $f_m$ :

$$\beta = \frac{\Delta f}{f_m} = \frac{\Delta f}{B}$$

$$\phi_{EM}^N(t) = A \cos(2\pi f_c t + \beta \sin(2\pi f_m t))$$

$$\phi_{EM}^N(t) = A_c \cos(2\pi f_c t) \cos(\beta \sin(2\pi f_m t)) - A_c \sin(2\pi f_c t) \sin(\beta \sin(2\pi f_m t))$$

Note:  $\cos(\beta \sin(2\pi f_m t)) \approx 1$ , and  $\sin(\beta \sin(2\pi f_m t)) \approx \beta \sin(2\pi f_m t)$

$$\phi_{EM}^N(t) = A \cos(2\pi f_c t) - \beta \sin(2\pi f_c t) \cdot \sin(2\pi f_m t)$$

$$\phi_{EM}^N(t) = A_c \cos(2\pi f_c t) + \frac{1}{2} \beta A_c [\cos(2\pi(f_c + f_m)t) - \cos(2\pi(f_c - f_m)t)]$$

**NBFM**

Result from AM modulation with tone frequency:

$$\phi_{AM}(t) = A_c \cos(2\pi f_c t) + \frac{1}{2} \mu A_c [\cos(2\pi(f_c + f_m)t) + \cos(2\pi(f_c - f_m)t)]$$

**AM**

The difference is the sign (i.e., phase) of the difference frequency term.

Conclusion: The NBFM bandwidth is comparable to that of AM.

$\therefore$  Bandwidth:  $B_T = 2f_m$



## Case II – Wideband FM (WBFM)

WBPM requires  $\beta \gg 1$  radian

For wideband FM we have a nonlinear process, with single tone modulation:

$$\varphi_{FM}^{WB}(t) = \text{Re} \left[ A_C \exp \left( j2\pi f_c t + j\beta \sin(2\pi f_m t) \right) \right]$$

We need to expand the exponential into a Fourier series so that we can analyze  $\varphi_{FM}^{WB}(t)$ .

$$\varphi_{FM}^{WB}(t) = A_C \sum_{n=-\infty}^{\infty} J_n(\beta) \cdot \cos(2\pi(f_c + nf_m)t)$$

$$\beta = \frac{\Delta f}{f_m} = \frac{\Delta f}{B}$$

where the coefficients  $J_n(\beta)$  are Bessel functions.

Spectral analysis from tone modulation of WBFM: Lathi & Ding; pp. 264-270  
We will not cover this section in ES442 but rather focus upon a physical interpretation of the spectrum spread.

# FM (or PM) Requires Much More bandwidth Than AM

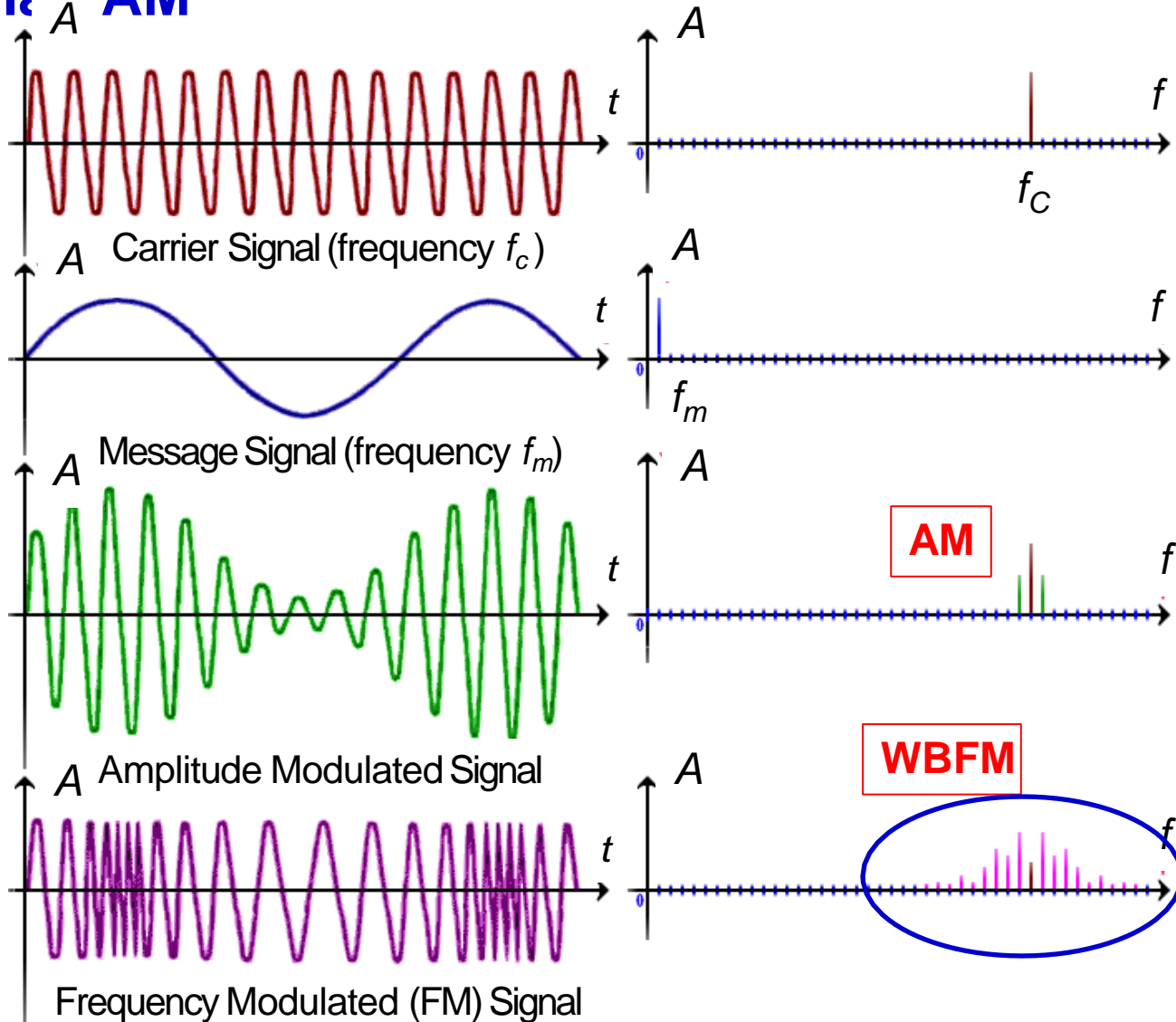

# FM Spectra as Function of Modulation Index $\beta$

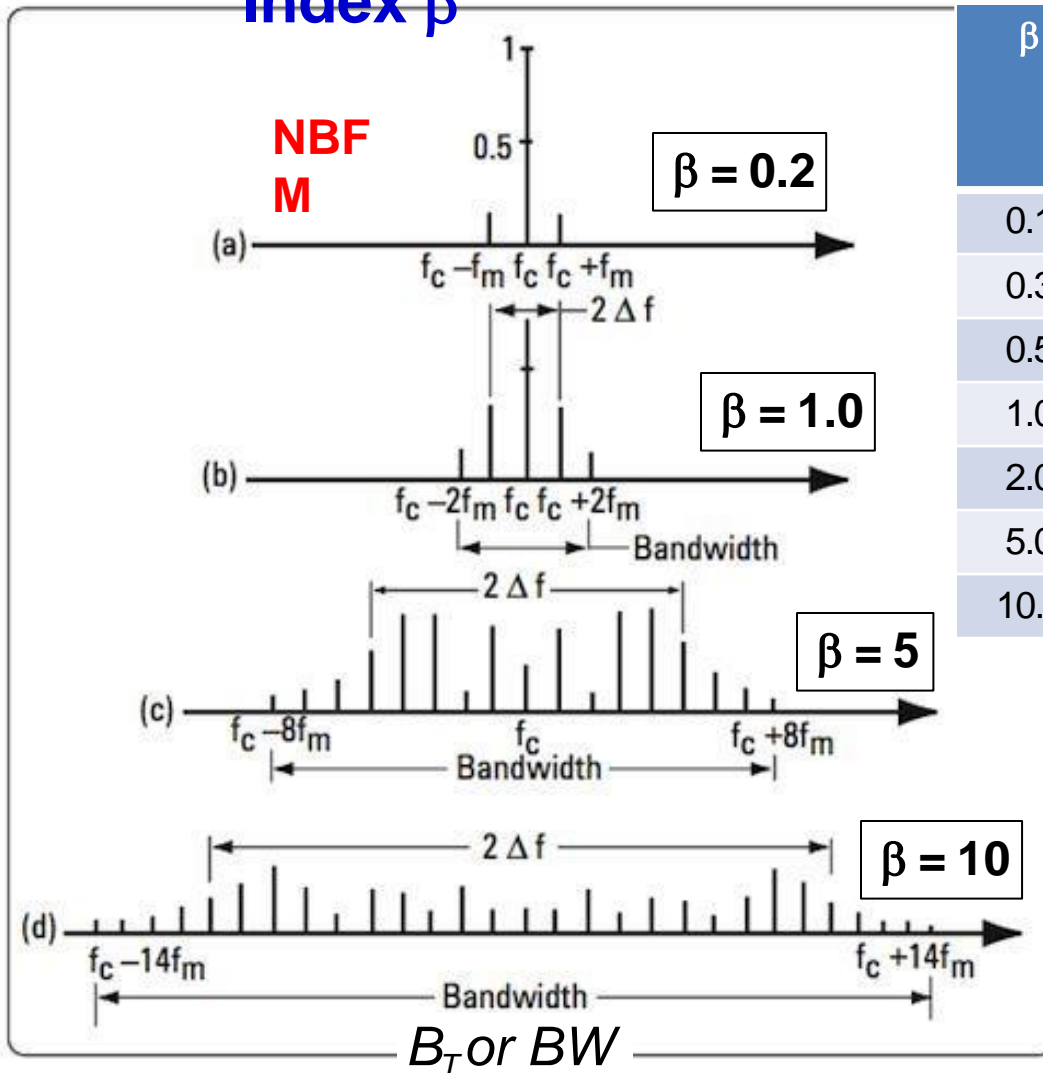

$\beta$	Number of Sidebands	Bandwidth
0.1	2	$2 f_m$
0.3	4	$4 f_m$
0.5	4	$4 f_m$
1.0	6	$6 f_m$
2.0	8	$8 f_m$
5.0	16	$16 f_m$
10.0	28	$28 f_m$

Single tone modulation

$$\beta = \frac{\Delta f}{f_m}$$

# Spectra of an FM Signal

Single-tone modulation

$$\beta = \frac{\Delta f}{f_m}$$

$\Delta f$  increasing,  
 $f_m$  is constant

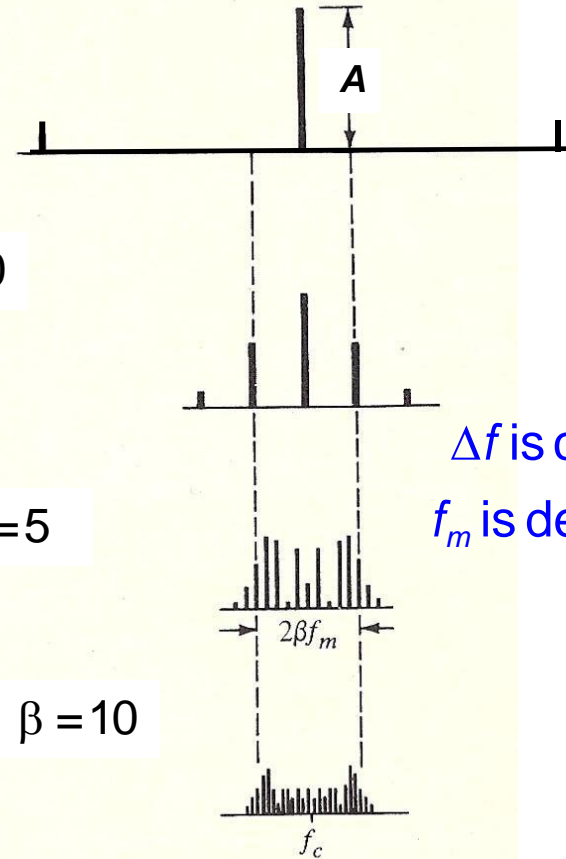
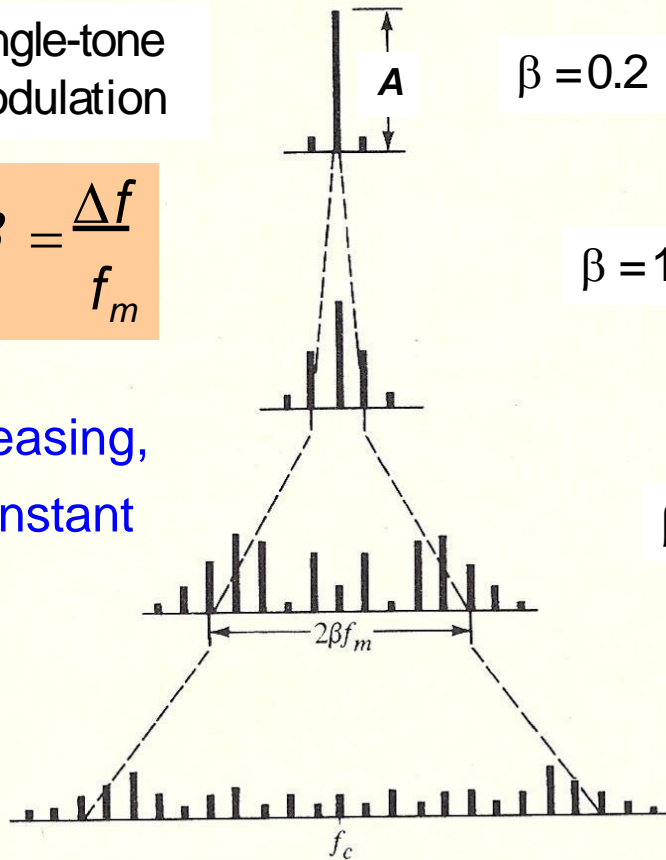

$\Delta f$  is constant,  
 $f_m$  is decreasing

From A. Bruce Carlson, *Communication Systems, An Introduction to Signals and Noise in Electrical Communication*, 2<sup>nd</sup> edition, 1975; Chapter 6, Figure 6.5, Page 229.

# Measured Spectra of an FM Radio Signal

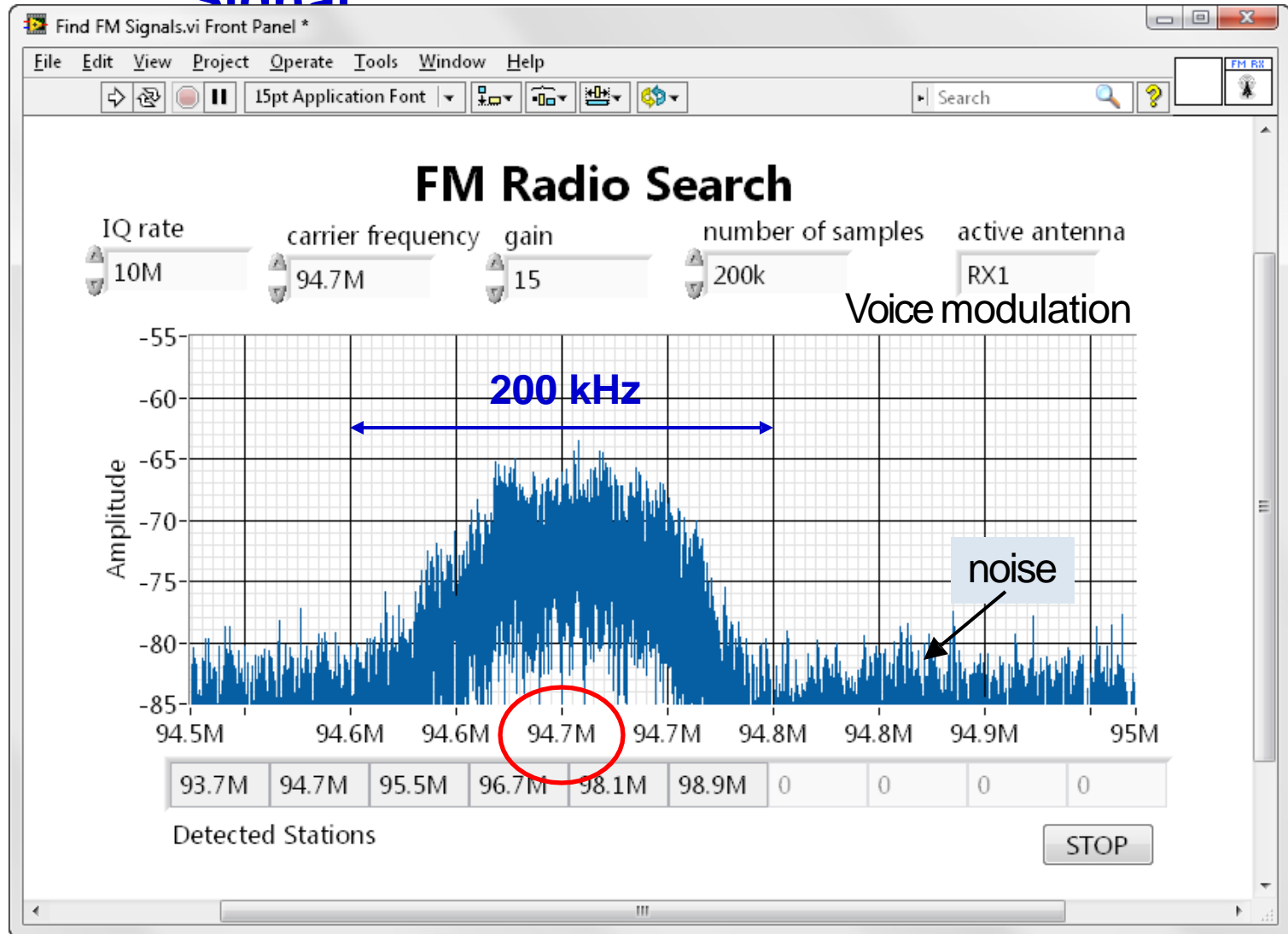

# Selecting an FM Station

Broadcast FM Radio covers from 88 MHz to 108 MHz  
100 stations – 200 kHz spacing  
between FM stations

- Consider tuning in an FM radio station.
- What allows your radio to isolate one station from all of the adjacent stations?

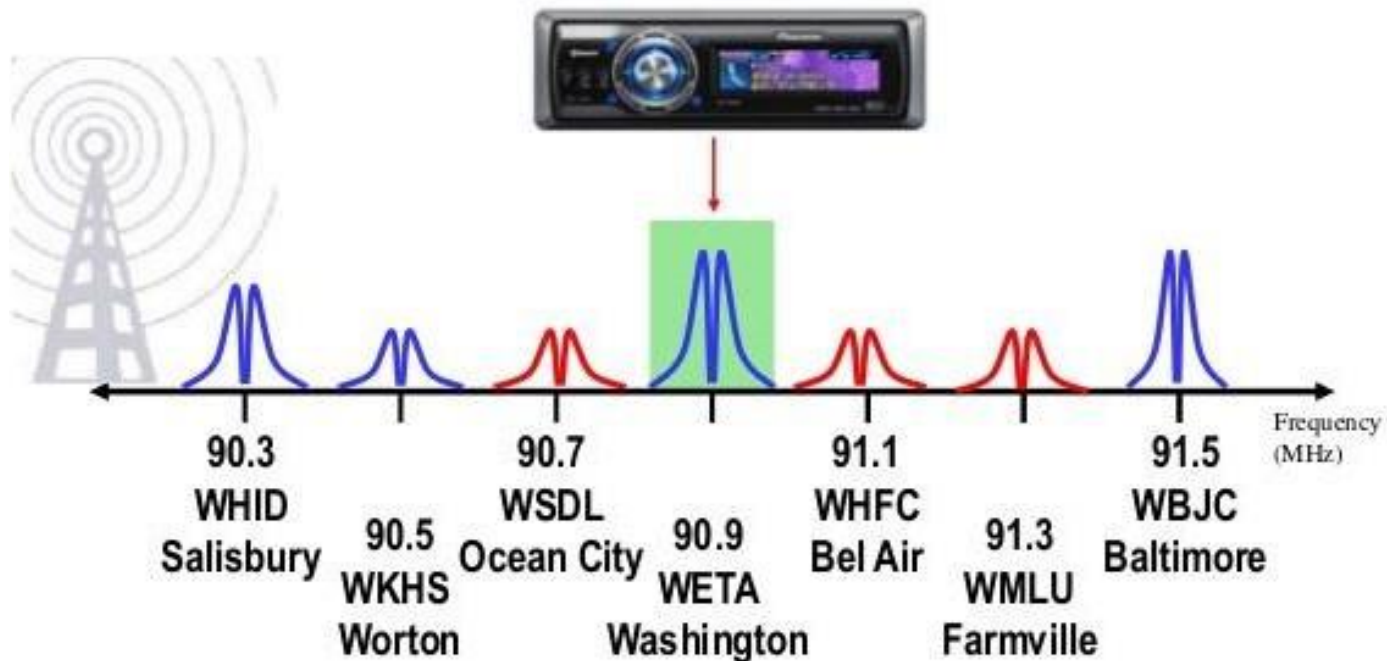

# Specifications for Commercial FM Transmissions

Service Type	Frequency Band	Channel Bandwidth	Maximum Deviation	Highest Audio
Commercial <u>FM Radio Broadcast</u>	88.0 to 108.0 MHz	200 kHz	±75 kHz	15 kHz
Television Sound (analog)	4.5 MHz above the picture carrier frequency	100 kHz	±25 kHz monaural & ±50 kHz stereo	15 kHz
Public safety – Police, Fire, Ambulance, Taxi, Forestry, Utilities, & Transportation	50 MHz and 122 MHz to 174 MHz	20 kHz	±5 kHz	3 kHz
Amateur, CE, A & Business band Radio	2.3 MHz to 470 MHz	15 kHz	±6 kHz	3 kHz

Question For FM broadcast what is the modulation index  $\beta$ ?

# FM Bandwidth and the Modulation Index $\beta$

Lathi & Ding – Chapter 5 – see pages 261 to

263  
Narrowband FM (NBFM) –  $\beta \ll 1$  radian

$$B_{FM}^{NB} \cong 2B \quad \text{where } B \text{ is the bandwidth of } m(t)$$

Wideband FM (WBFM) –  $\beta \gg 1$  radian

$$B_{FM}^{WB} \cong 2(\Delta f + B) = 2B(\beta + 1) \quad \text{Carson's Rule}$$

$$1) \quad \text{or} \quad B_T \cong 2(\Delta f + f_m)$$

Peak frequency deviation is  $\Delta\omega = k_f A_m$

$$\text{Modulation index } \beta = \frac{\Delta f}{f_m} = \frac{\Delta f}{B}$$



# Phasor Construction of an FM Signal

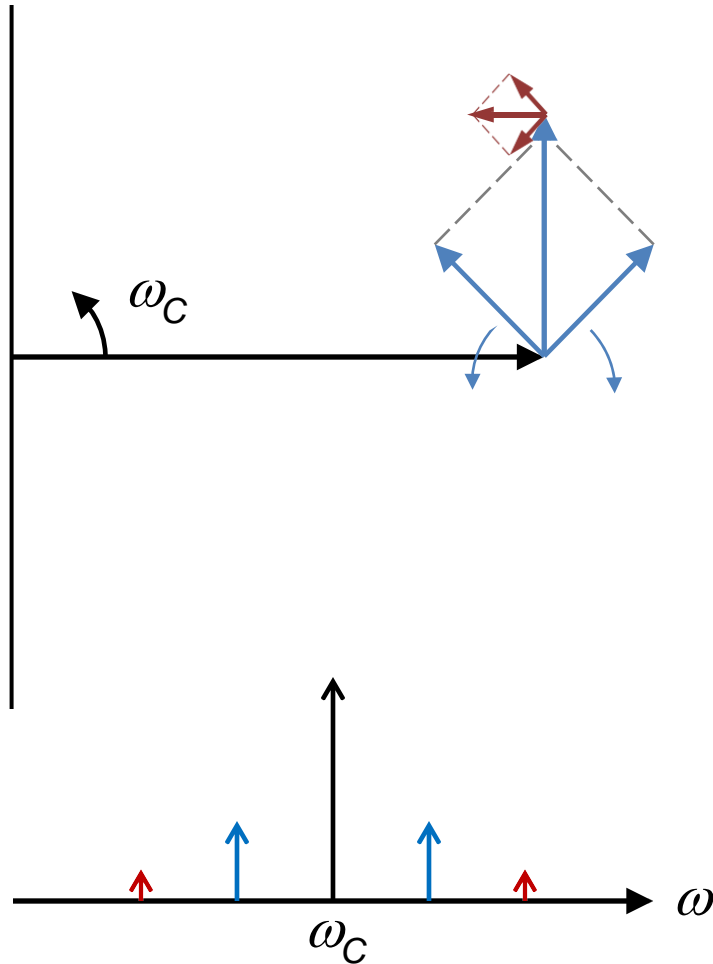

We are constrained by constant amplitude for both FM and PM signals.

This is **NBFM**. The next slide shows an animation of this in operation.

# Sidebands Constructed From Phasors in FM

## Modulation

Animation showing how phase modulation works in the phasor picture --phase modulation with a sinusoidal modulation waveform and a modulation depth of  $\pi/4$  radians. The blue line segments represent the phasors at the carrier and the harmonics of the modulation frequency.

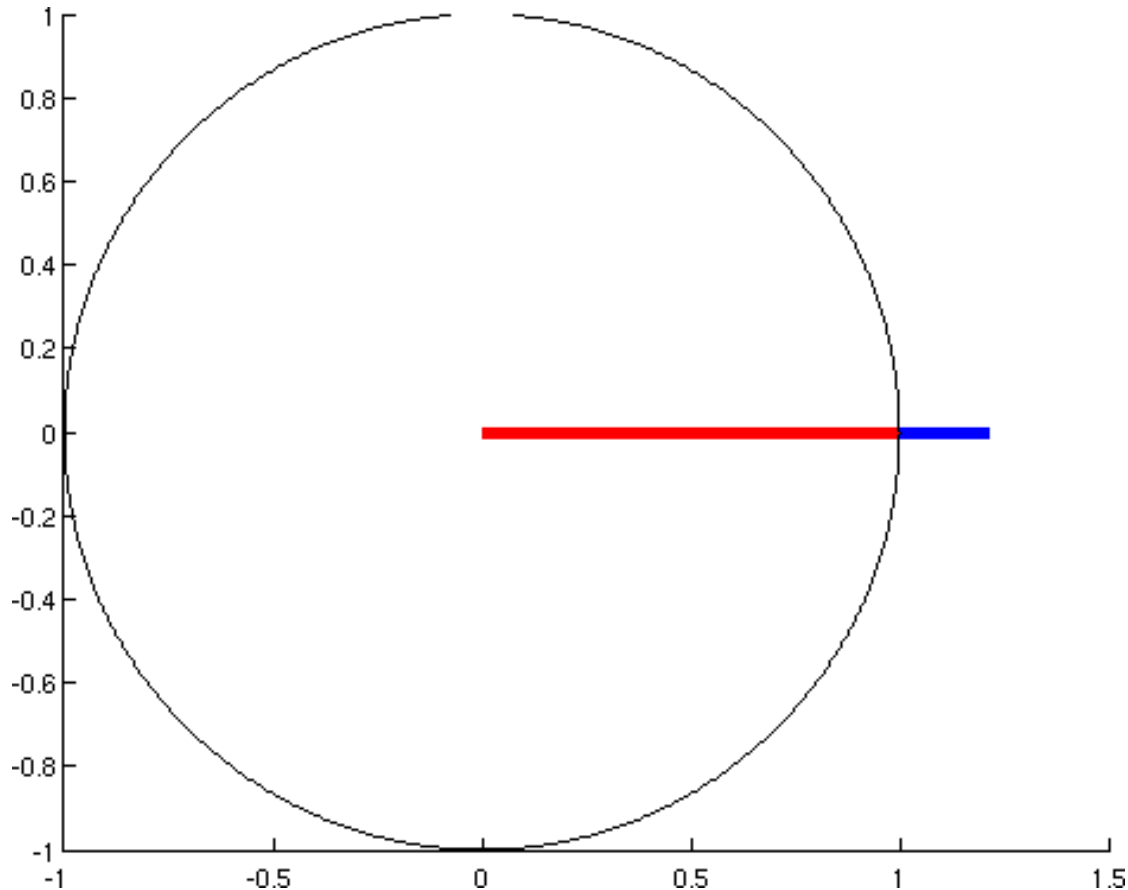

# Direct Generation of FM Signal Using a VCO

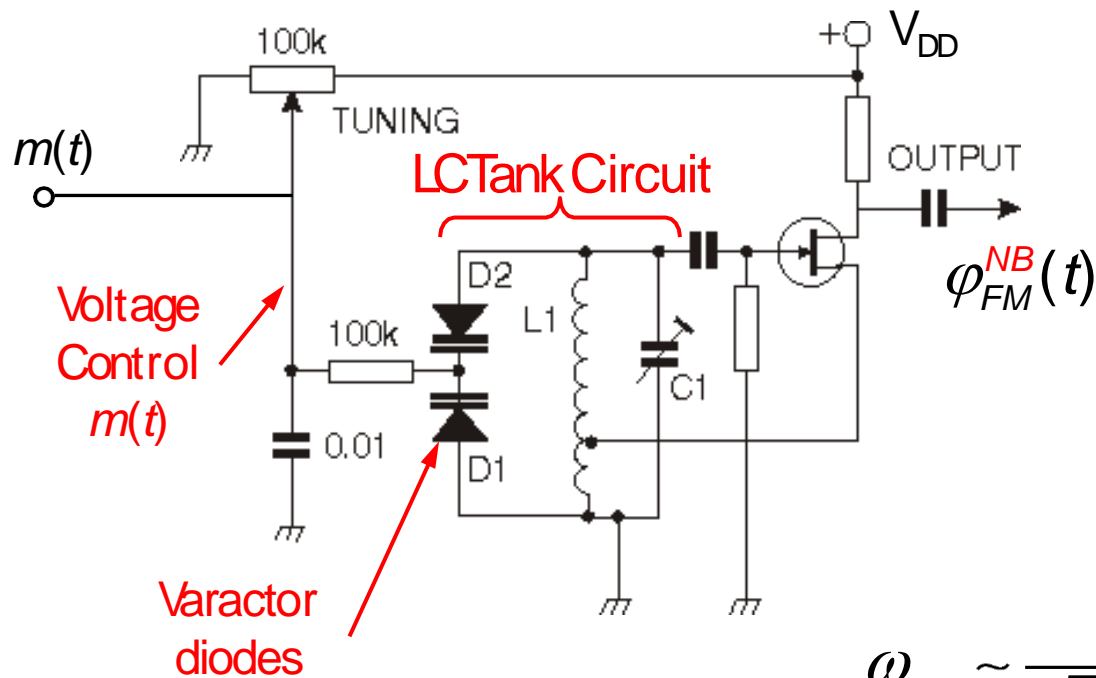

$$\omega_{os} \sim \frac{1}{\sqrt{L_1 C_e} q}$$

# Indirect Generation of an FM Signal Using Multiplication

In this method, a narrowband frequency-modulated signal is first generated and then a frequency multiplier is used to increase the modulation index. The concept is shown below:

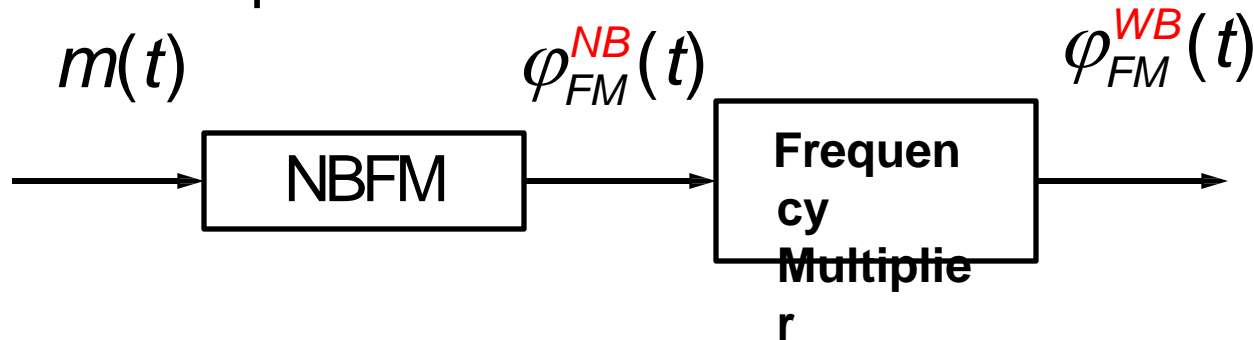

A frequency multiplier is used to increase both the carrier frequency and the modulation index by integer  $N$ .

# Armstrong Indirect FM Transmitter Example

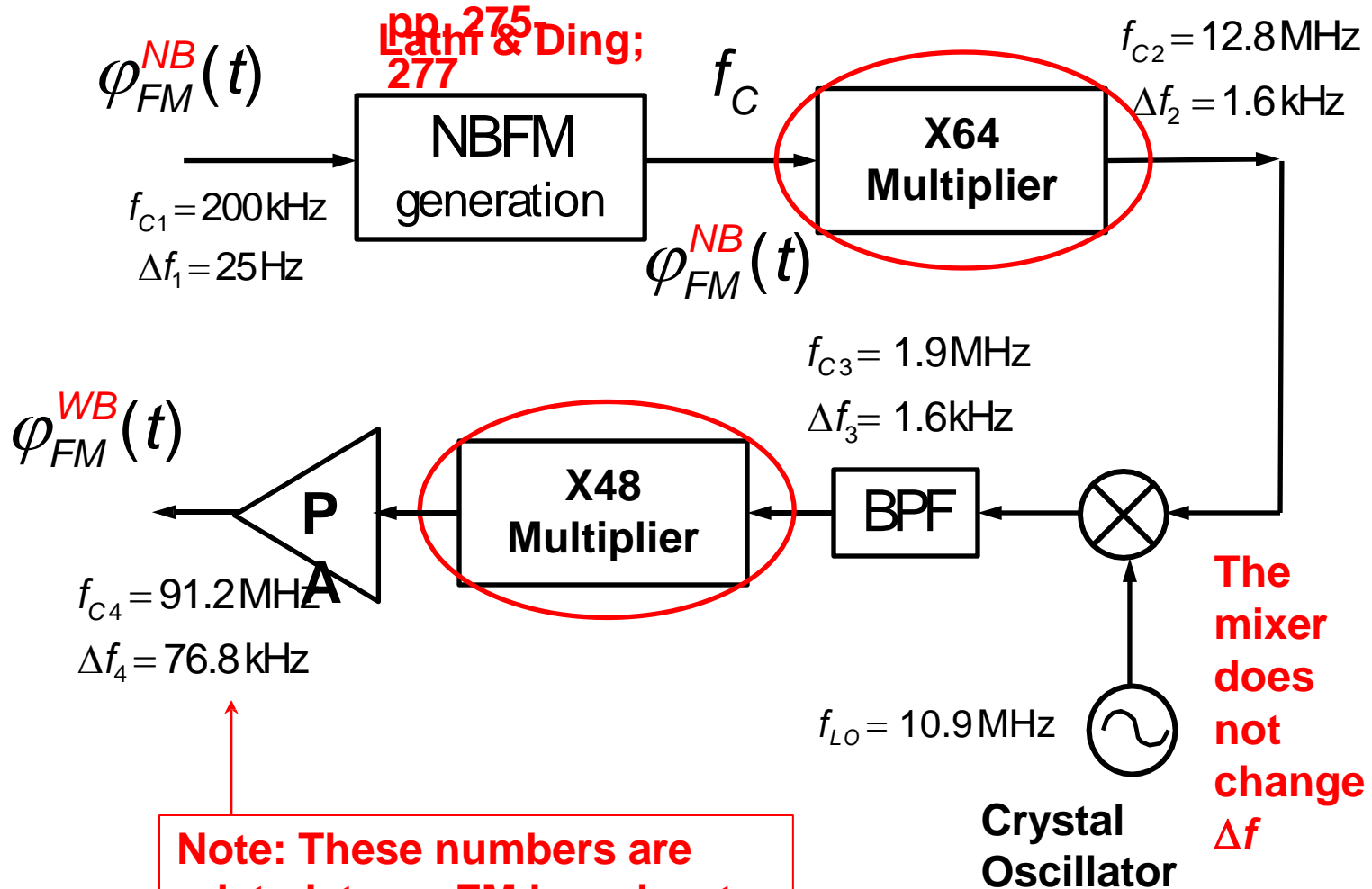

**Note: These numbers are related to an FM broadcast radio station.**

# Generation of Narrowband Frequency Modulation (NBFM)

$$\varphi_{FM}(t) = A \cos \left( \omega_c t + k_f \int_{-\infty}^t m(\alpha) d\alpha \right)$$

NBFM requires  $\beta \ll 1$  radian

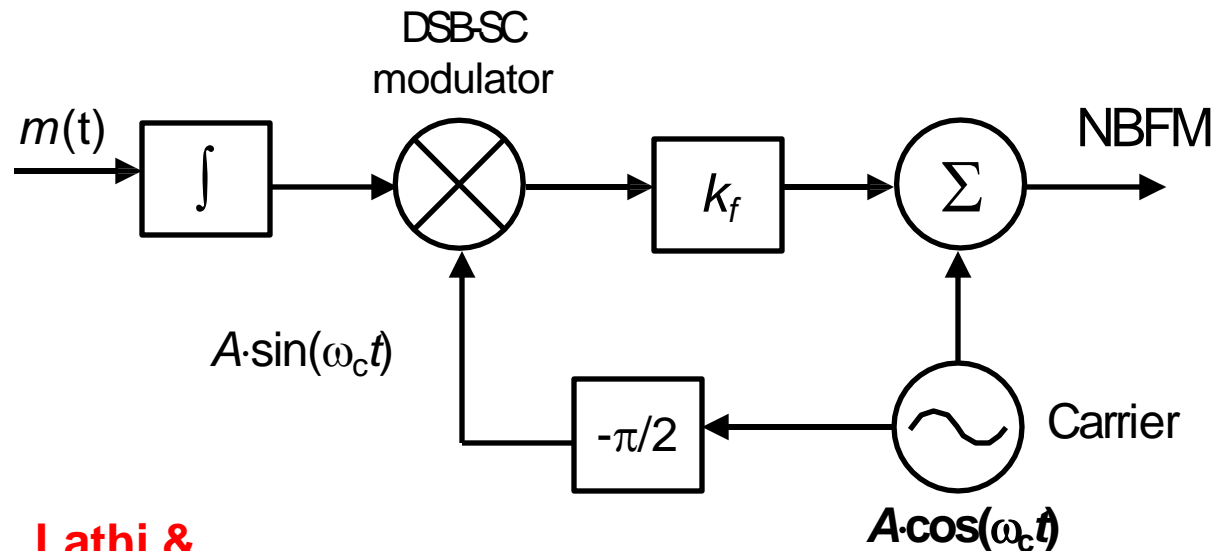

**Lathi &  
Ding;  
Figure  
5.10  
Page 276**

# Generation of Narrowband Phase Modulation (NBPM)

$$\varphi_{PM}(t) = A \cos(\omega_c t + k_p m(t))$$

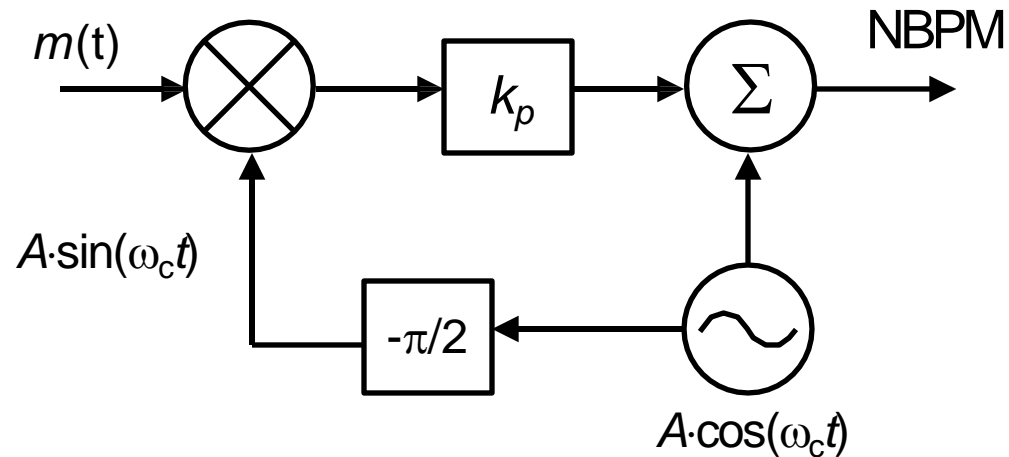

## Advantages of

## FM

# Advantages of frequency modulation

**1. Resilient to noise:** The main advantage of frequency modulation is a reduction in noise. As most noise is amplitude based, this can be removed by running the received signal through a limiter so that only frequency variations remain.

**2. Resilient to signal strength variations:** In the same way that amplitude noise can be removed, so too can signal variations due to channel degradation because it does not suffer from amplitude variations as the signal level varies. This makes FM ideal for use in mobile applications where signal levels constantly vary.

**3. Does not require linear amplifiers in the transmitter:** As only frequency changes contain the information carried, amplifiers in the transmitter need not be linear.

**4. Enables greater efficiency :** The use of non-linear amplifiers (*e.g.*, class C and class D/E amplifiers) means that transmitter efficiency levels can be higher. This results from linear amplifiers being inherently inefficient.



## Disadvantages of

## FM

### Disadvantages of frequency modulation

**1. Requires more complicated demodulator:** One of the disadvantages is that the demodulator is a more complicated, and hence more expensive than the very simple diode detectors used in AM.

**2. Sidebands extend to infinity either side:** The sidebands for an FM transmission theoretically extend out to infinity. To limit the bandwidth of the transmission, filters are used, and these introduce some distortion of the signal.

# Practical Frequency Demodulators

Frequency discriminators can be built using various ways:

- FM slope detector
- Balanced discriminator
- Quadrature demodulators
- Phase locked loops (superior technique)
- Zero crossing detector

# FM Slope Detector Performs FM to AM Conversion

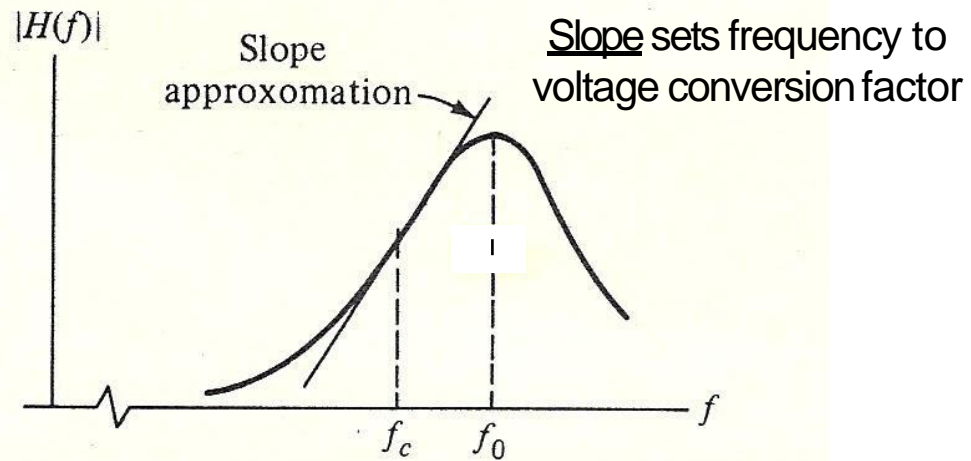
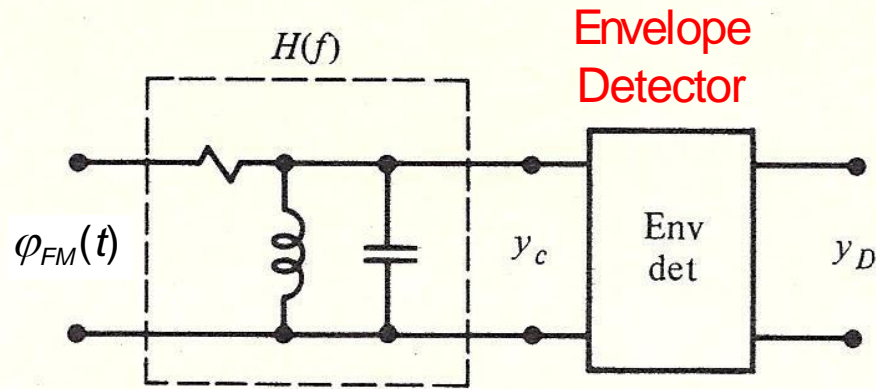

# Balanced Discriminator (Foster-Seeley Discriminator)

Tuned Circuit  
Envelope Detector

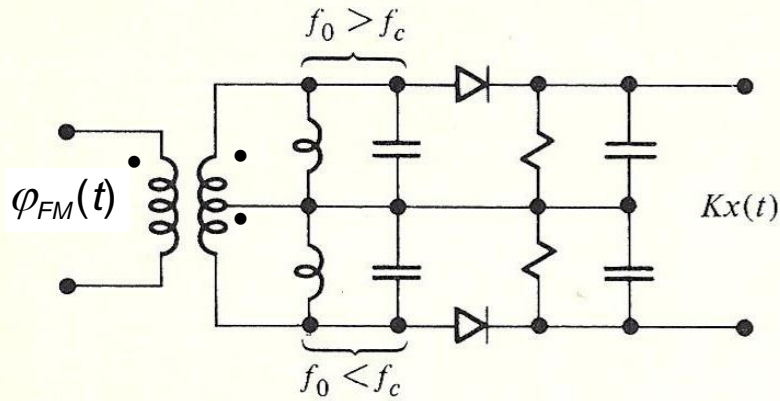

(a)

Centered around  
 $f_c$

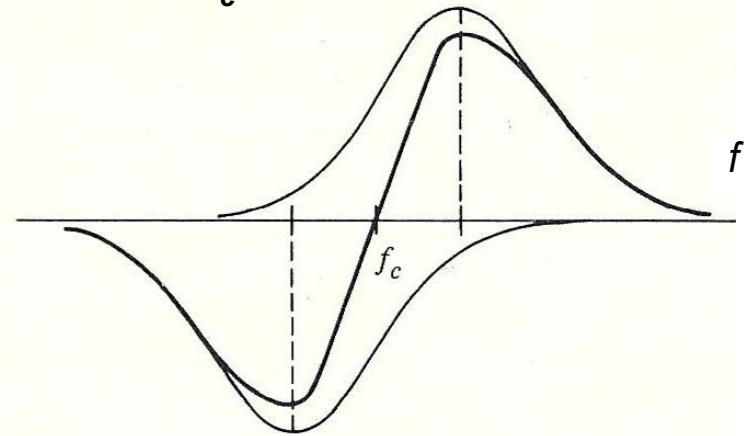

(b)

Transfer Characteristics

# Quadrature Demodulator – Block Diagram

FM signal is converted into PM signal

PM signal is used to recover the message signal  $m(t)$

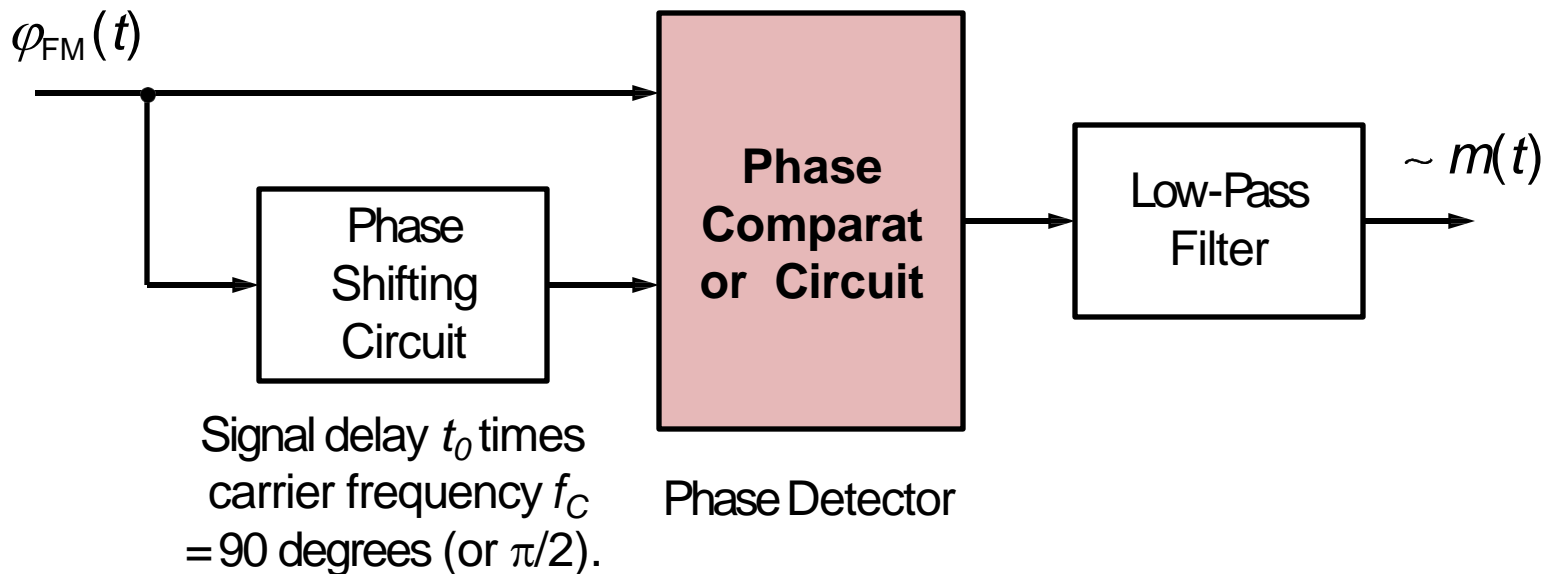

# Using XOR Gate for Phase Frequency Detector

- **Purpose:** To produce a signal current or voltage, proportional to the difference in phase or frequency between two input signals.

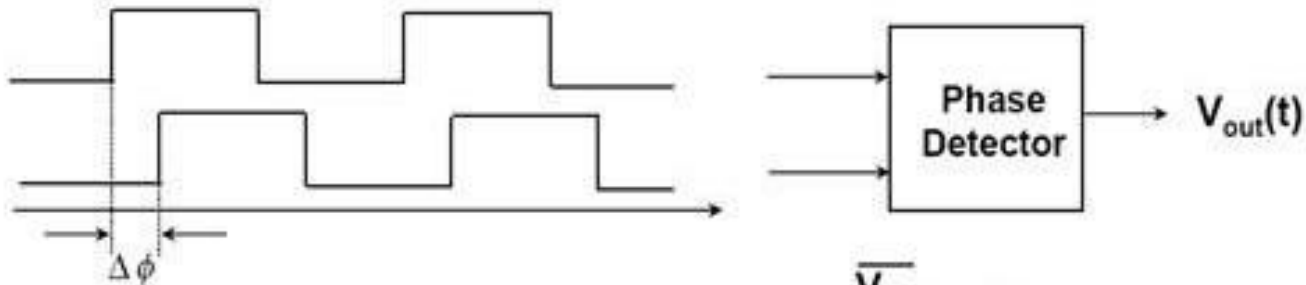

$$\overline{V_{out}} = K_D \Delta\phi$$

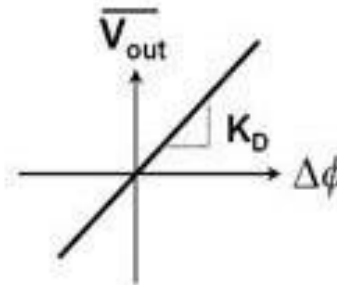

- **Example**

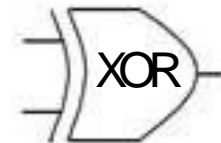
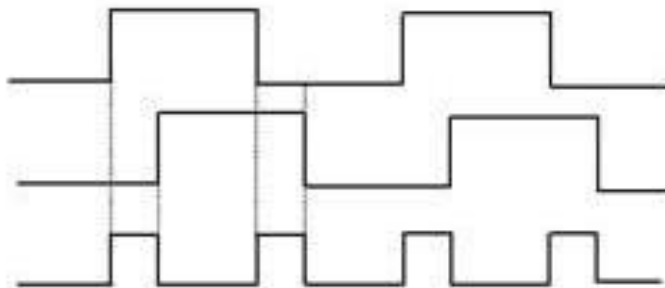

A	B	Output
0	0	0
0	1	1
1	0	1
1	1	0

# Quadrature Demodulator – Implementation

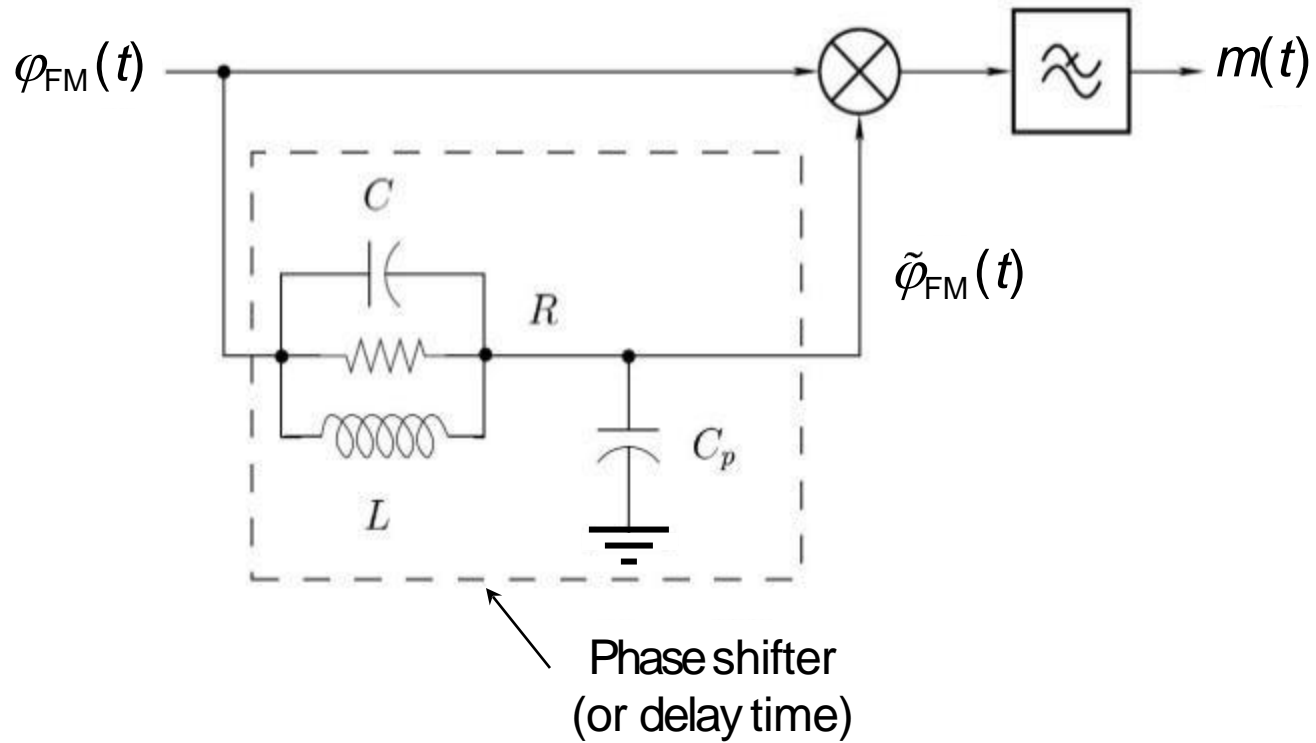

# Phase-Locked Loops

A PLL consists of three basic components:

- Phase detector
- Loop filter
- Voltage-controlled oscillator (VCO)

PLL Diagram:

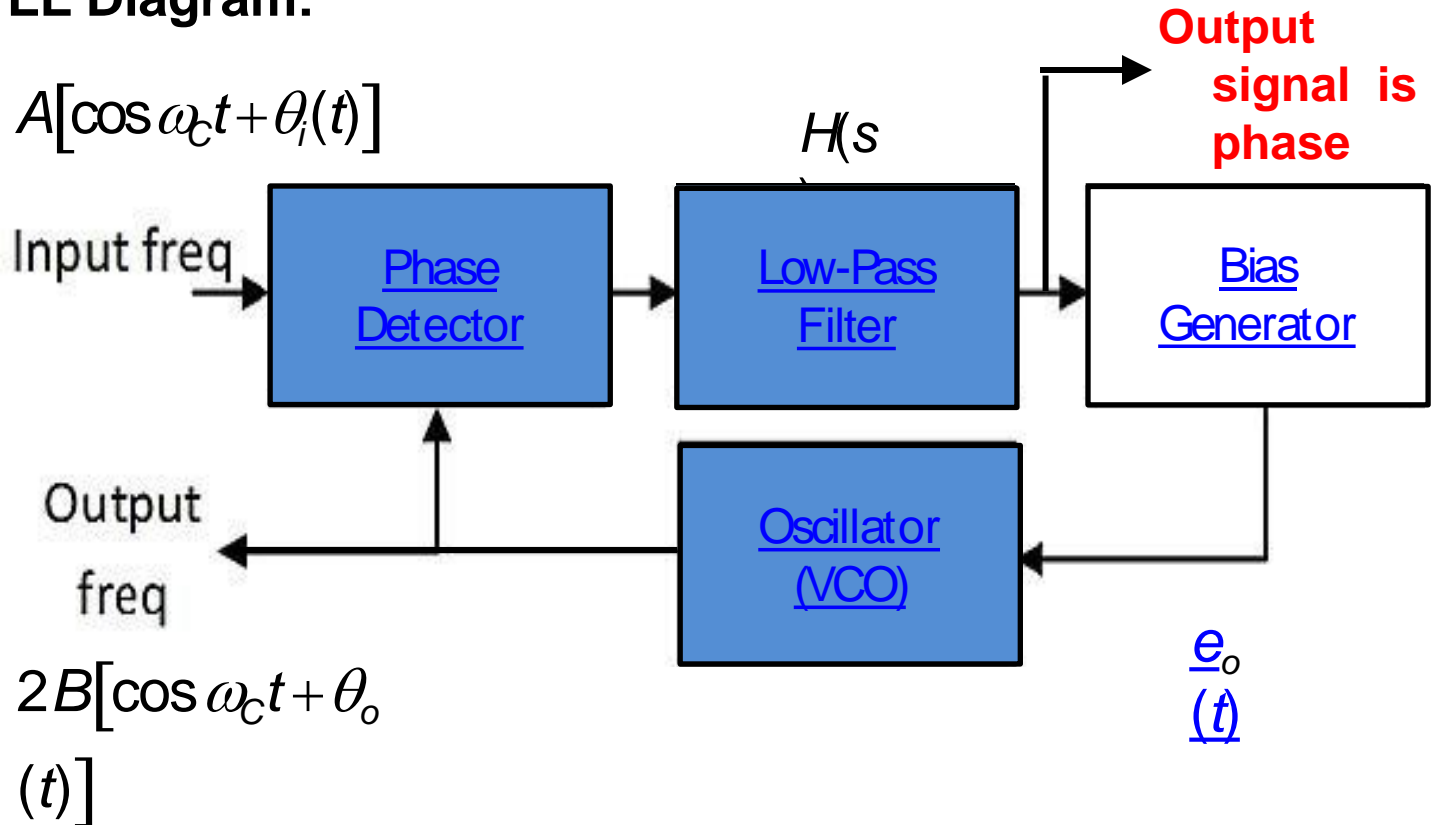



## Zero-Crossing Detectors

- Zero-Crossing Detectors are also used because of advances in digital integrated circuits.
- These are the frequency counters designed to measure the instantaneous frequency by the number of zero crossings.
- The rate of zero crossings is equal to the instantaneous frequency of the input signal

# Zero-Crossing Detector Illustration

## Zero crossing detector

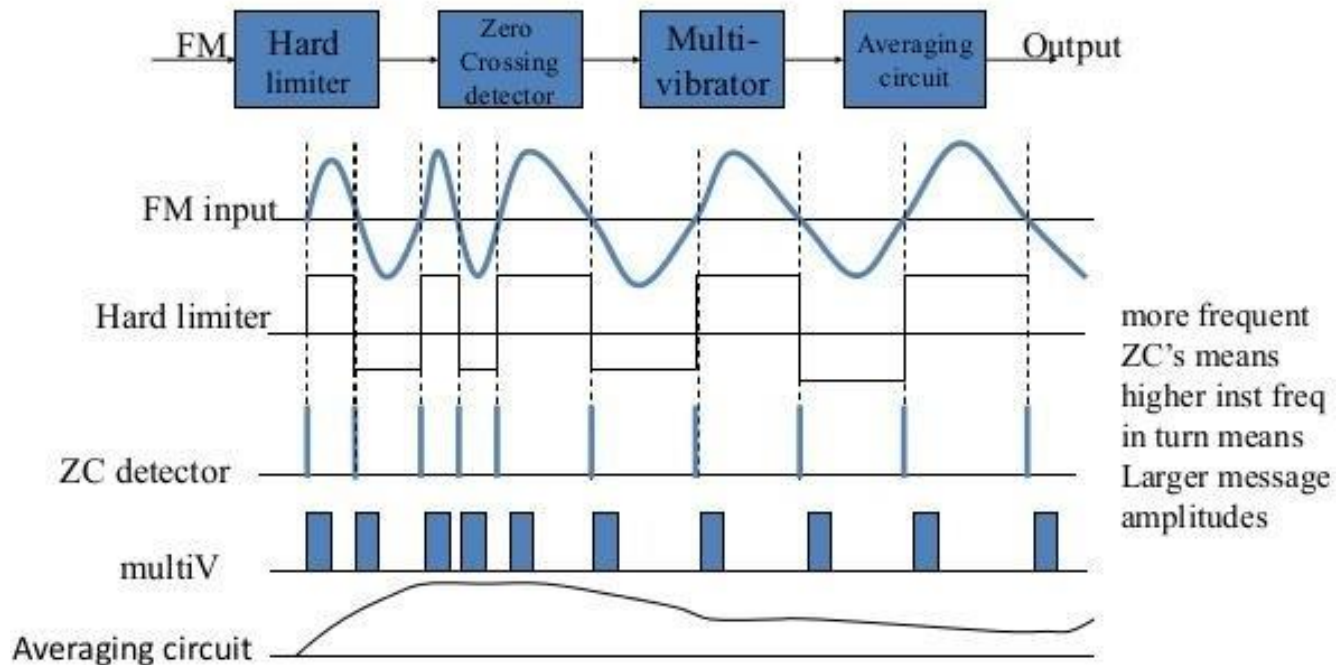

<https://www.slideshare.net/avocado1111/angle-modulation-35636989>

## Example

- A single tone FM signal is  
$$\varphi_{FM}(t) = 10 \left[ \cos \left( 2\pi(10^6)t + 8\sin(2\pi(10^3)t) \right) \right]$$

Determine

- a) the carrier frequency  $f_c$
- b) the modulation index  $\beta$
- c) the peak frequency deviation  $\Delta f$
- d) the bandwidth of  $\varphi_{FM}(t)$

## Solution to Example

Start with the basic FM equation:

$$\varphi_{FM}(t) = A_C \left[ \cos(2\pi f_c t + \beta \sin(2\pi f_m t)) \right]$$

Compare this to

$$\varphi_{FM}(t) = 10 \left[ \cos(2\pi(10^6)t + 8\sin(2\pi(10^3)t)) \right]$$

(a) We see by inspection that  $f_c = 1,000,000$  Hz and  $f_m = 1000$  Hz.

(b) The modulation index is  $\beta = 8$ .

(c) The peak deviation frequency  $\Delta f$  is

$$\Delta f = \beta \cdot f_m = 8 \cdot 1000 = 8,000 \text{ Hz}$$

(d) The bandwidth is

$$B_{FM} = 2 f_m (\beta + 1) = 2,000(8 + 1) = 18,000 \text{ Hz}$$

# Pre-Emphasis and De-Emphasis in FM

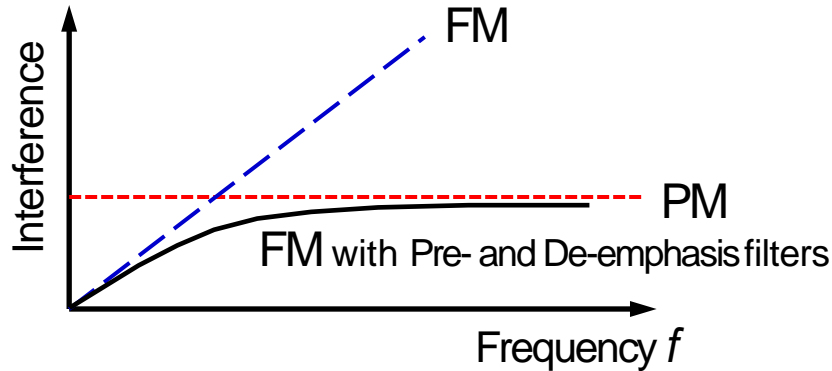

Channel noise acts as interference in FM and is uniform over the entire BW. Voice and music have more energy at lower frequencies, so we need to “emphasize” their upper frequencies by filtering. However, the HF emphasis must be removed at the receiver using a de-emphasis filter.

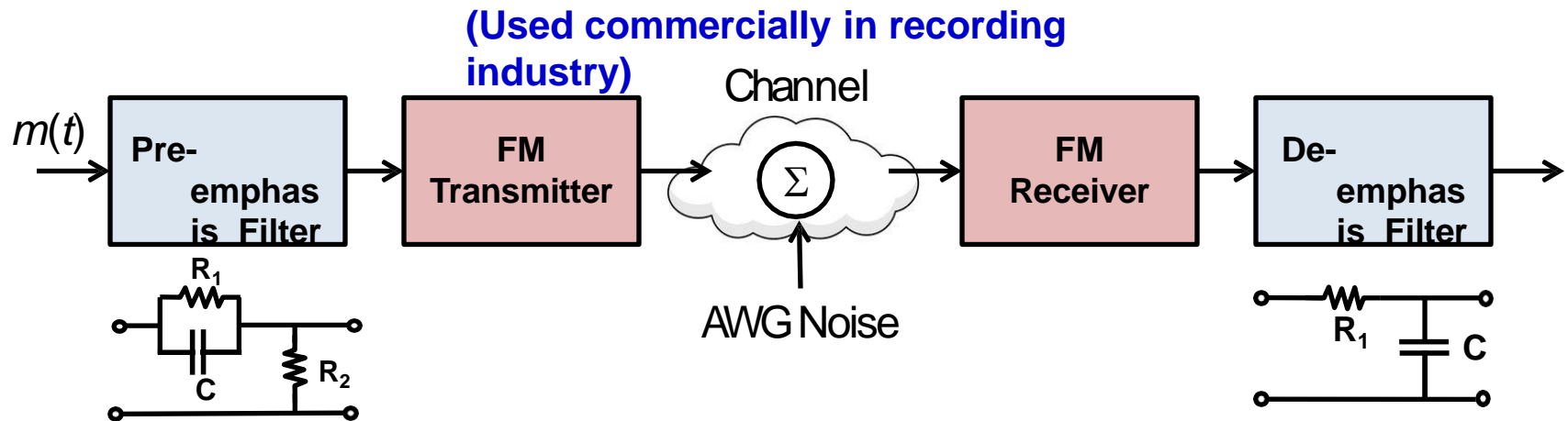

Filtering improves SNR in FM transmission.

# Typical Pre-Emphasis and De-Emphasis

Transmitter	Receiver
-------------	----------

## Pre-emphasis Filter

Filter  $R_1$

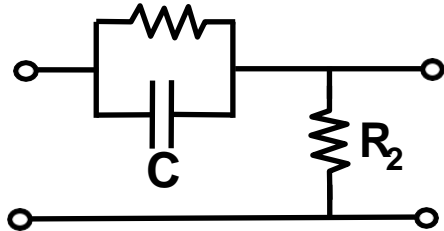

$$H(\omega) = \frac{V_{out}}{V_{in}} = \frac{1 + j\omega R_1 C}{1 + j\omega (R_1 \parallel R_2) C}$$

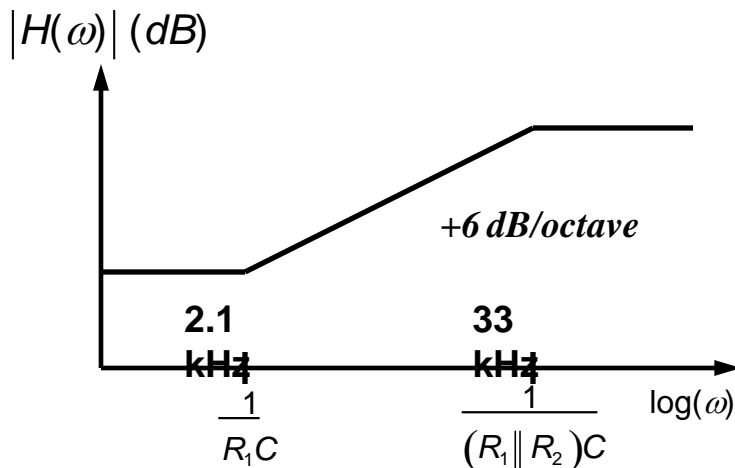

## De-emphasis

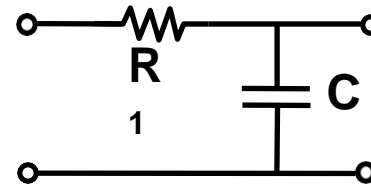

$$H(\omega) = \frac{V_{out}}{V_{in}} = \frac{1}{1 + j\omega R_1 C}$$

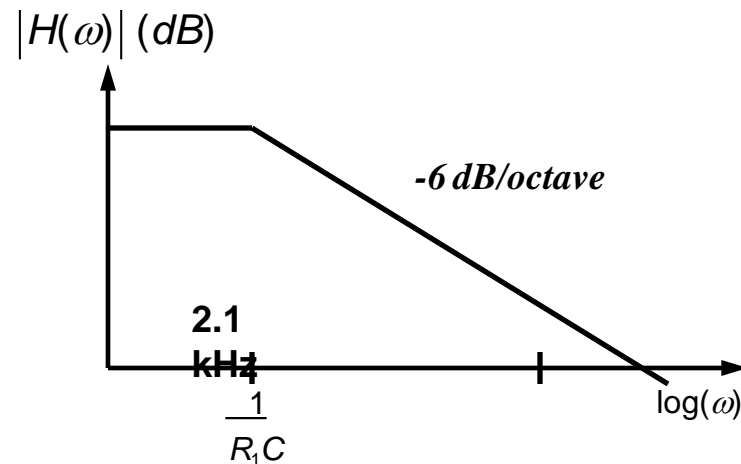

Lathi &  
Ding;  
Chapter 5,  
pp. 286-289

# Analog and Digital FM Cellular Telephones

**1G** analog cellular telephone (1983) – AMPS (Advanced Mobile Phone Service)

First use of cellular concept

Used 30 kHz channel spacing (but voice BW was  $B = 3$  kHz)

Peak frequency deviation  $\Delta f = 12$  kHz, and

$$B_T = 2(\Delta f + B) = 2(12 \text{ kHz} + 3 \text{ kHz}) = 30 \text{ kHz}$$

Two channels (30 kHz each); one for uplink and one for downlink

Used FM for voice and FSK for data communication

No protection from eavesdroppers

Successor to AMPS was GSM (Global System for Mobile) in early 1990s

GSM is **2G** cellular telephone

Still used by nearly 50% of world's population

GSM was a digital communication system

Modulating signal is a bit stream representing voice signal

Used Gaussian Minimum Shift Keying (GMSK) – **later in EE 442**

Channel bandwidth is 200 kHz (simultaneously shared by 32 users)

This is 4.8 times improvement over AMPS

***More to come on cellular . . .***

# Digital Carrier Modulation – ASK, FSK and PSK

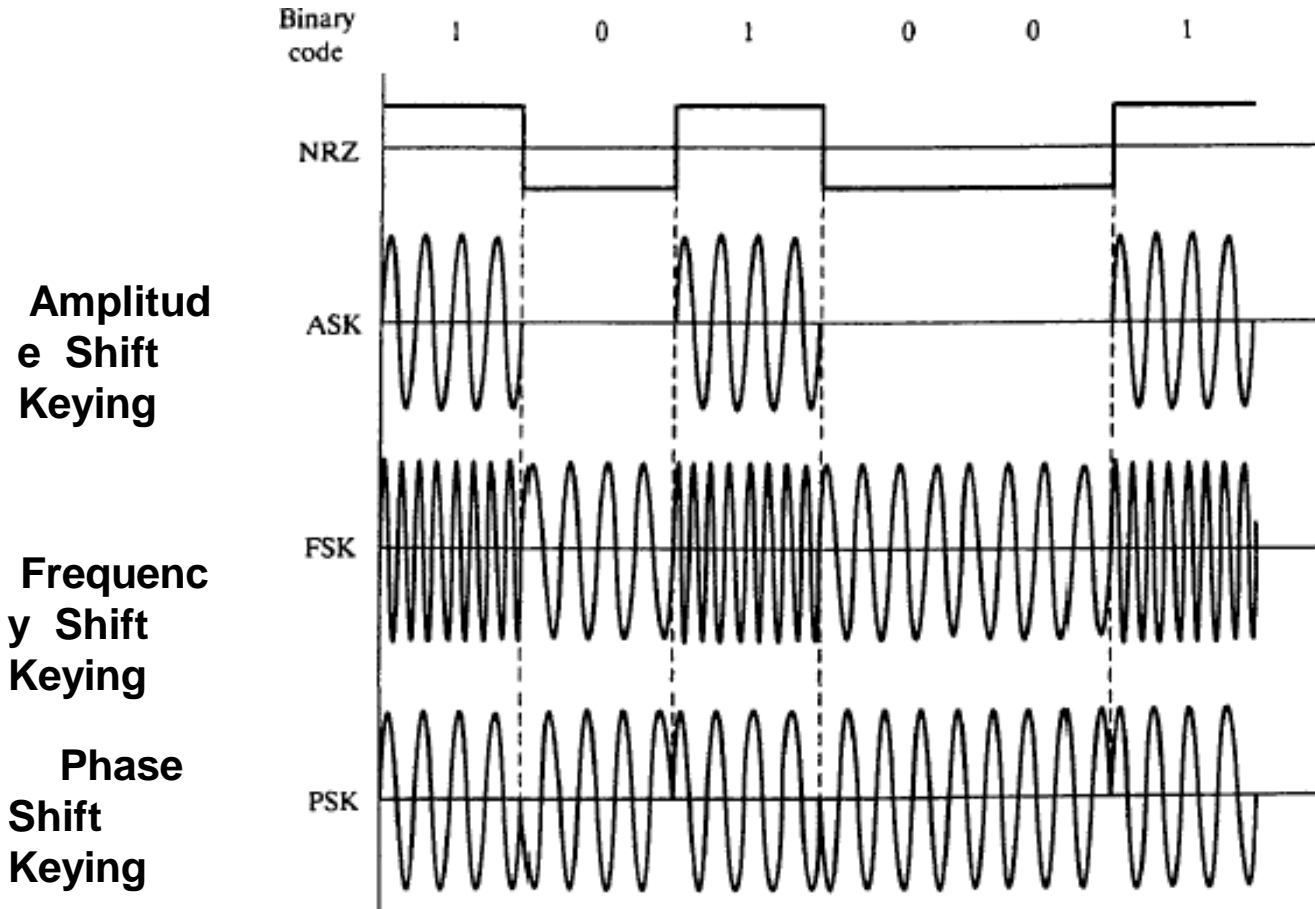

Digital Signals



# Questions?

