

**TOPIC :**  
**FUELING SYSTEMS OF IC  
ENGINE**

**(PART II)**

**LECTURE (05 + 06)**  
**ENGR. MANSOOR ALI ZAHEER**  
**ASSISTANT PROFESSOR**  
**MECHANICAL ENGINEERING DEPARTMENT**  
**UNIVERSITY OF SARGODHA**

# FUEL INJECTION SYSTEM

- ① Fuel-Injection System, method of delivering fuel to an internal-combustion engine.
- ② In a fuel-injection system, electronically controlled fuel injectors spray measured amounts of fuel into each of the engine's cylinders where the fuel is burned, powering the engine.
- ③ Modern, computer-operated fuel injection produces more power, lower exhaust emissions, improved fuel economy, and smoother operation than a carburetor system.
- ④ Fuel injection began replacing the carburetor during the 1980s and is now the fuel-delivery system for virtually all new automobiles. Fuel injection has always been the standard fuel-delivery system for diesel engines.

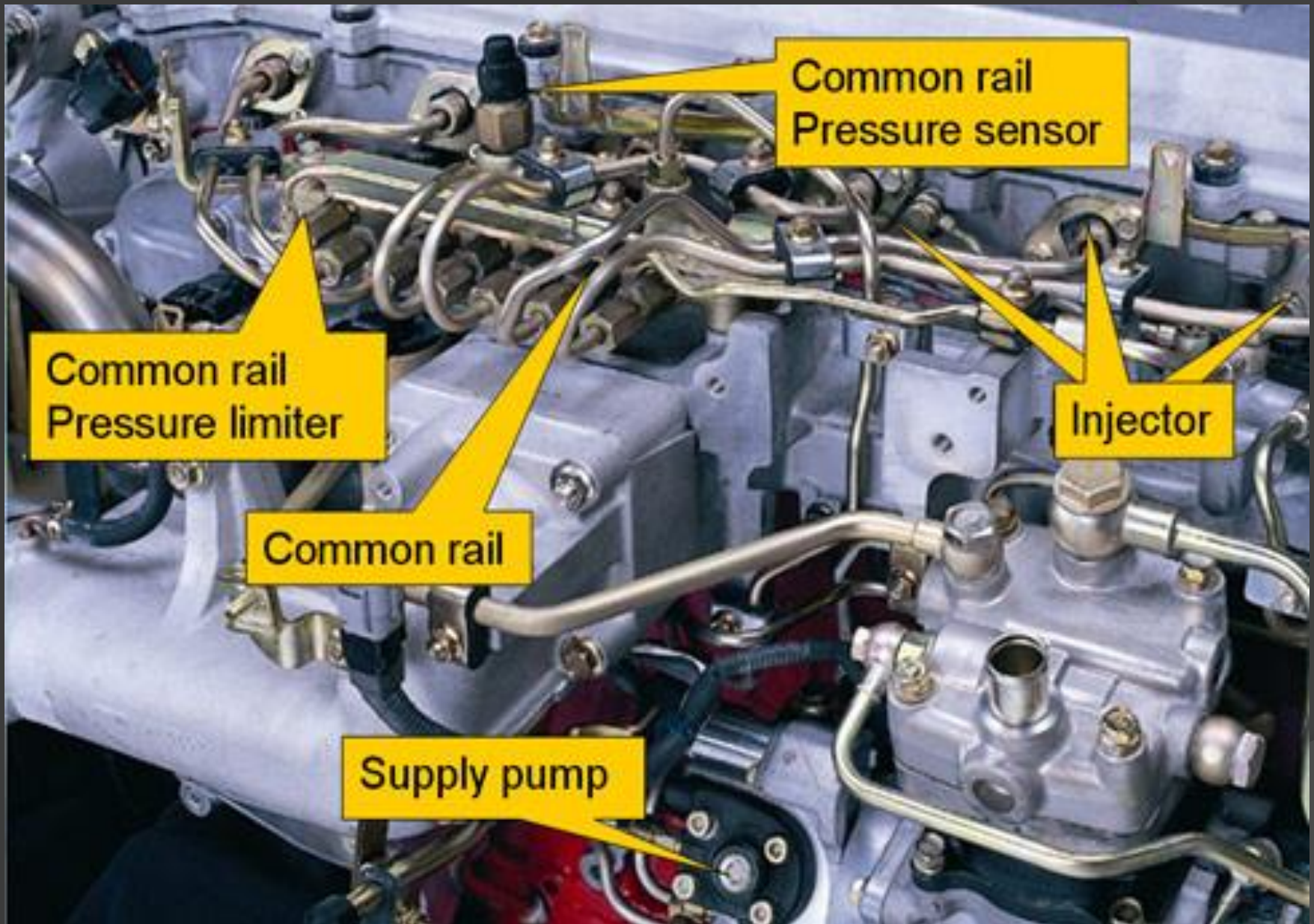

# FUEL INJECTION SYSTEM

- ◎ The fuel injection may be purely mechanical, purely electronic or a mix of the two. Early systems were mechanical but from about 1980 onward more and more systems were completely electronic. By the middle of the decade, nearly all new passenger vehicles were equipped with electronic fuel injection. The 1990 Subaru Justy was the last passenger car sold in the United States with a carburetor.
- ◎ The modern electronic systems that cars are equipped with today utilize a number of sensors to monitor engine conditions, and an electronic control unit (ECU) to accurately calculate the needed amount of fuel. Thus fuel injection can increase fuel efficiency and reduce pollution.

# FUEL INJECTION SYSTEM

## ◎ COMPARISON WITH CARBURETOR

- ◎ As in a traditional carburetor, fuel is converted to a fine spray and mixed with air. Traditional carburetor forces the incoming air through a venturi to pull the fuel into the air stream, While a fuel injection system forces the fuel through nozzles under pressure to inject the fuel into the air stream without requiring a venturi.
- ◎ The use of a venturi reduces volumetric efficiency by approximately 15%, which results in a reduction in engine power. Thus, a fuel injection system increases the power that an engine with the same engine displacement will produce. Additionally, fuel injection allows for more precise control over the mixture of fuel and air, both in proportion and in uniformity.

# FUEL INJECTION SYSTEM

## ◎ COMPONENTS

- ◎ The components of a fuel-injection system include **injectors** that atomize (spray a cloud of tiny droplets) fuel, a **pump** that delivers fuel from a storage tank to the injector, a **variety of sensors** throughout the vehicle, and a computer, generally called an **electronic control module (ECM)**.
- ◎ The **sensors monitor** the engine transmission, air-intake, exhaust, vehicle speed, fuel flow, and many other things that affect engine performance.
- ◎ The **ECM uses this information to control fuel supply, the timing of fuel injections, and the mix of fuel and air in the engine's combustion chambers.**
- ◎ **Modern ECMs also control the engine's ignition system, which ignites fuel in the combustion chambers at precisely timed intervals to operate the engine efficiently.**

# FUEL INJECTION SYSTEM

## ◎ FUEL INJECTOR

- ◎ A typical injector has a nozzle, a needle valve that blocks the opening in the nozzle by expanded from it, and a compression spring.
- ◎ A pump controlled by the ECM shoots fuel into the injector with enough pressure to compress the spring. This pressure lifts the needle valve, which opens the nozzle.
- ◎ In another type of injector, the nozzle's opening is blocked by a small ball held in place by a plunger. The ECM controls a magnetic switch that pulls the plunger upward and lets fuel spray past the ball into the combustion chamber. Another signal from the ECM pushes the plunger, which pushes the ball into place and stops the flow of fuel.
- ◎ An ECM opens the injector nozzle, holds it open, and closes it after a precise interval, more than 1000 times per minute at highway speeds.





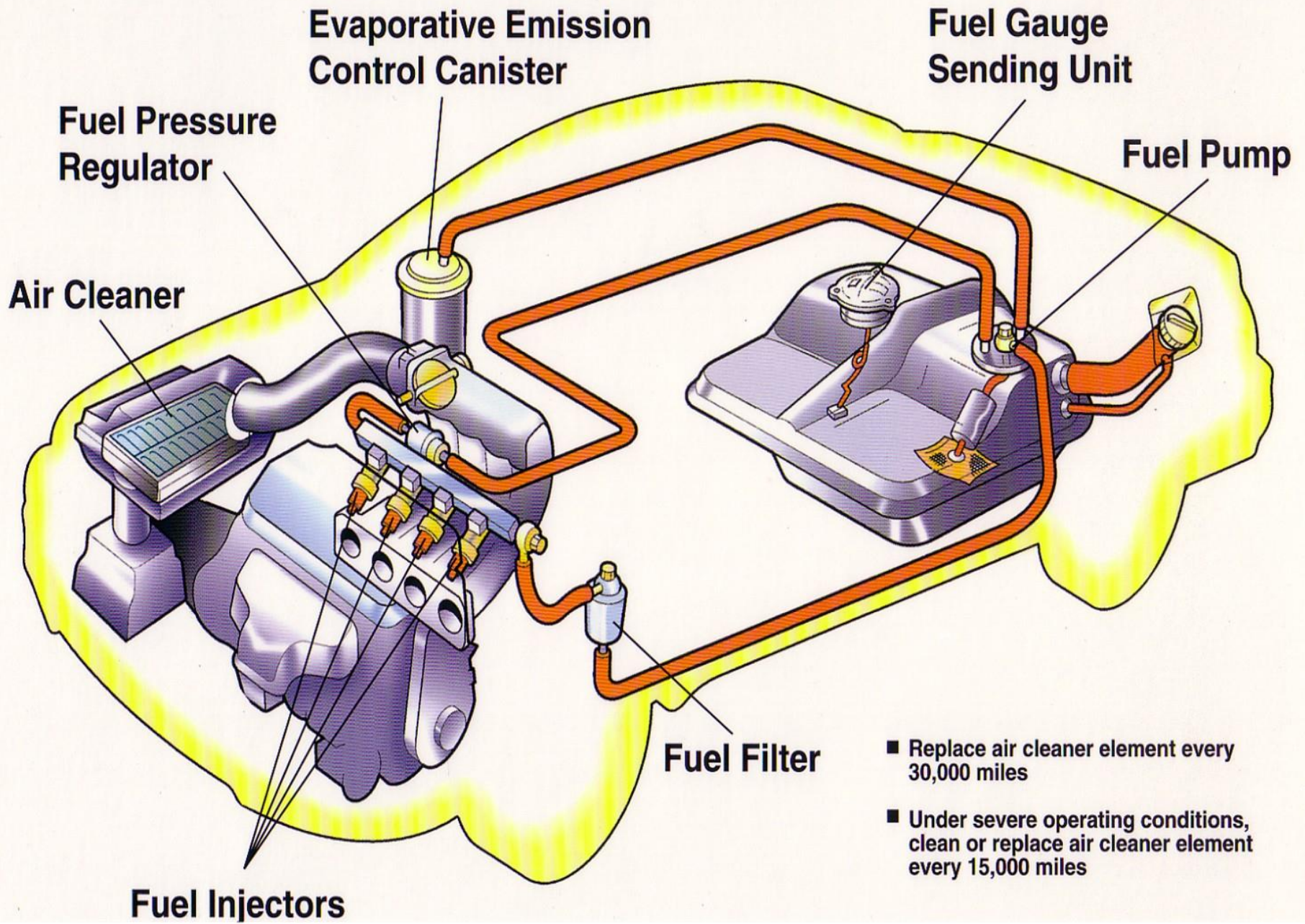

# FUEL INJECTION SYSTEM

## ◎ THROTTLE-BODY INJECTION

- ◎ Electronic throttle-body injection (normally called TBI, was introduced in the early 1980s as a transition technology to fully-electronic port injection. The system injects fuel into the throttle-body (a wet system), so fuel can condense and cling to the walls of the intake system, harming emissions. Computer-controlled TBI was inexpensive and simple.

# THROTTLE-BODY INJECTION

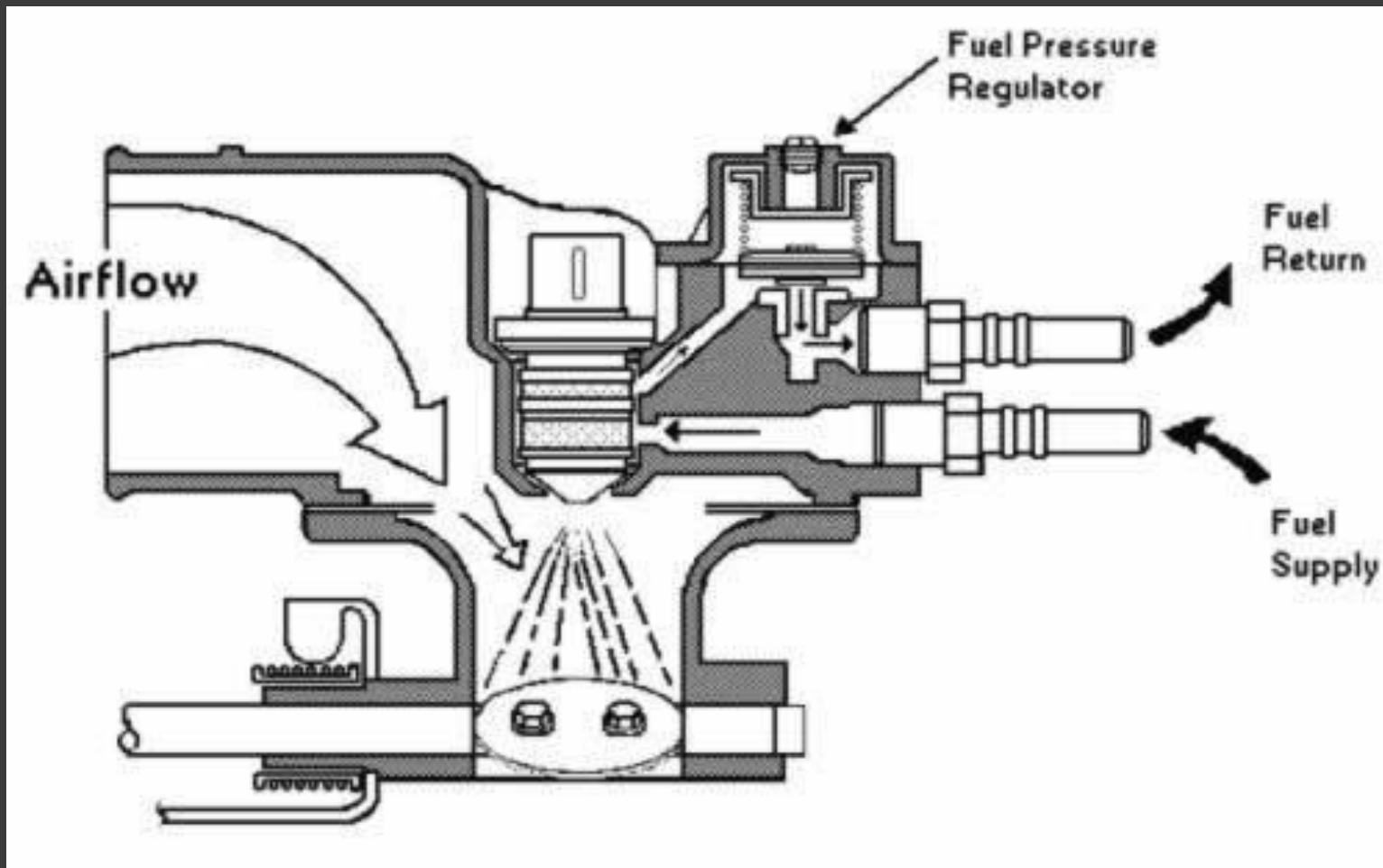

# THROTTLE-BODY INJECTION

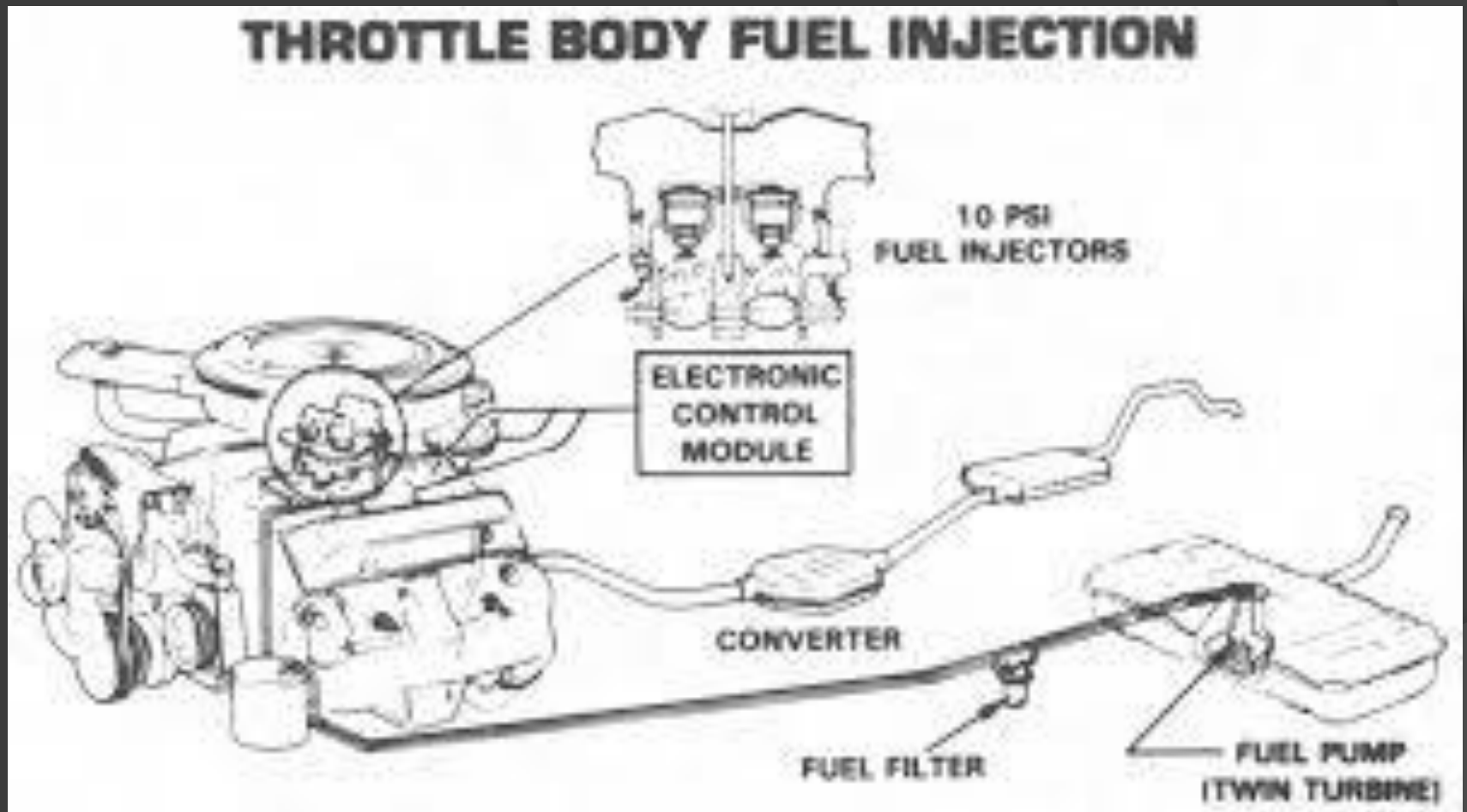

# FUEL INJECTION SYSTEM

## ◎ CENTRAL PORT INJECTION

- ◎ General Motors developed a new "in-between" technique called central port injection or CPI. It uses tubes from a central injector to spray fuel at the intake port rather than the throttle-body (it is a dry system). However, fuel is continuously injected to all ports simultaneously, which is less than optimal.

**Figure 78-18** A central port fuel-injection system.

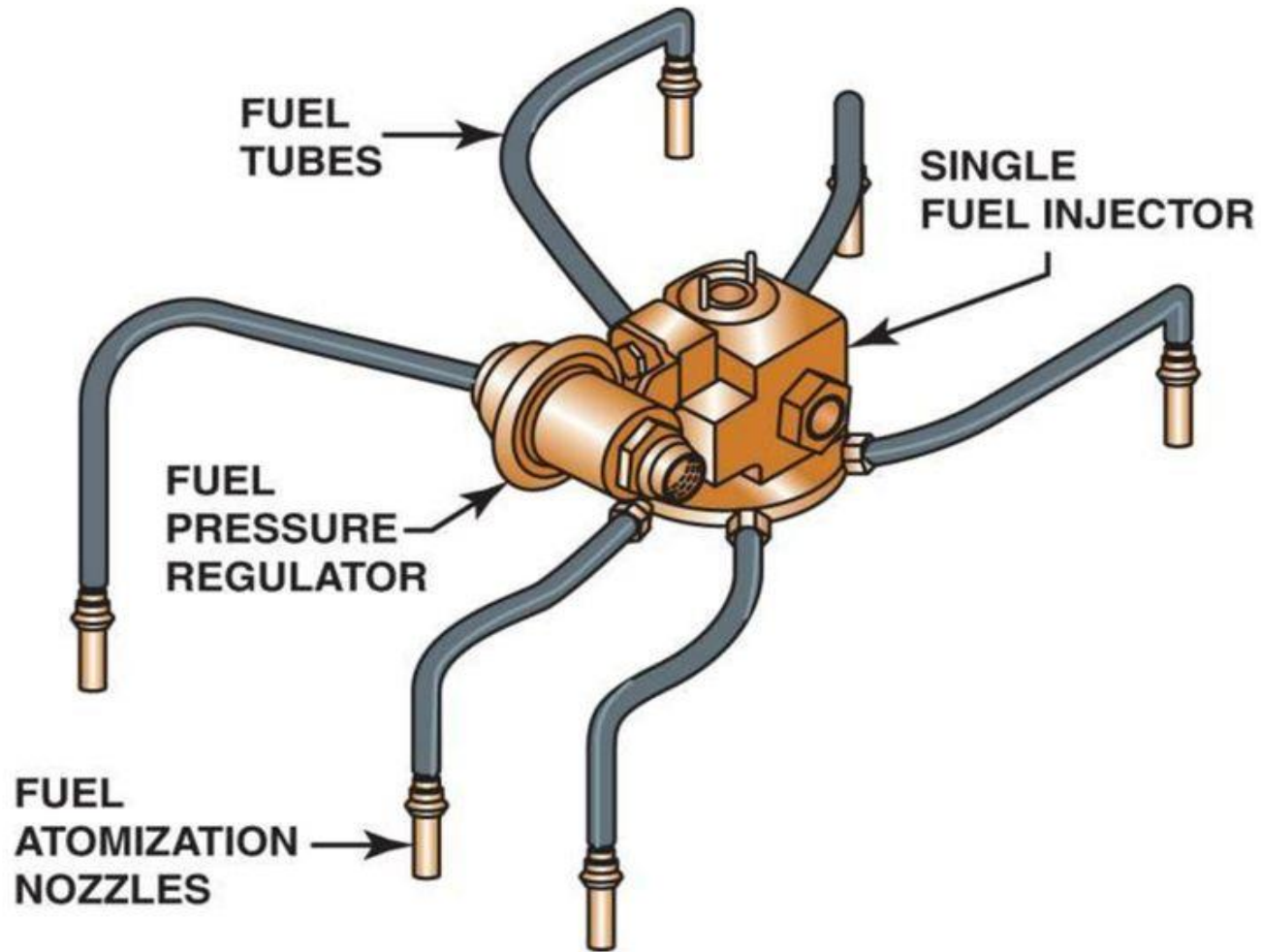



# FUEL INJECTION SYSTEM

## ⦿ MULTI-PORT FUEL INJECTION

- ⦿ The goal of all fuel injection systems is to carefully meter the amount and timing of fuel to each cylinder. This is achieved with the more sophisticated fuel injection systems, often called multi-port fuel injection (MFI) or sequential port fuel injection (SFI). It uses a single injector per cylinder and sprays the fuel right above the intake valves.



# FUEL INJECTION SYSTEM

## ◎ DIRECT INJECTION

- ◎ The newest method for petrol engines now is direct injection or DI. It has a special fuel injector inside the combustion chamber itself, along with the valves and spark plugs. This system is just appearing in the mid-2000s, and like most systems before, it is being pioneered in Diesel applications. This method was used in various WWII aircraft as well. Notable engines included the Daimler Benz DB 605 and later versions of the Wright R-3350 used in the B-29 Super fortress. In direct injection, the piston incorporates a depression which is where initial combustion takes place. Direct injection diesel engines are generally more efficient than indirect injection engines, but tend to be noisier.

# DIRECT INJECTION



# FUEL INJECTION SYSTEM

## ● HOW IT WORKS

- The injectors in a TBI system are located in the intake manifold close to where a carburetor was typically housed. The pistons in the cylinders create a partial vacuum that pulls fuel and air through the manifold into the combustion chambers. **Port-type fuel-injection systems, sometimes called multi-port systems,** have injectors that spray fuel directly into each cylinder's *intake port*—an opening through the engine into the combustion chamber. **A port-type injection is better able to deliver equal amounts of fuel to each cylinder.** Moving the injectors to the ports also permits alterations to the intake manifold that improve engine performance.

# FUEL INJECTION SYSTEM

## ● HOW IT WORKS

- To start the engine, the ECM regulates fuel flow and ignition timing according to preset specifications.
- As the engine warms up, sensors report temperatures in the intake manifold and the cylinder head, which forms the top of the combustion chamber.
- Other sensors relay information about the position of the crankshaft and whether fuel is igniting too early inside the combustion chambers. More sensors report vehicle speed, transmission status, changes in *manifold pressure* (the air pressure inside the intake manifold), and oxygen content of the exhaust gas.
- Using information from those and other sensors, the ECM adjusts the fuel-injection and ignition-timing systems for different driving conditions.

# FUEL INJECTION SYSTEM FOR DIESEL ENGINE

- FUEL INJECTION SYSTEM FOR DIESEL ENGINE CONSISTS OF
- Electronic distributor pump
- Electronic unit injector (EUI)
- High-pressure common rail

# FUEL INJECTION SYSTEM FOR DIESEL ENGINE

## Electronic Distributor Pump

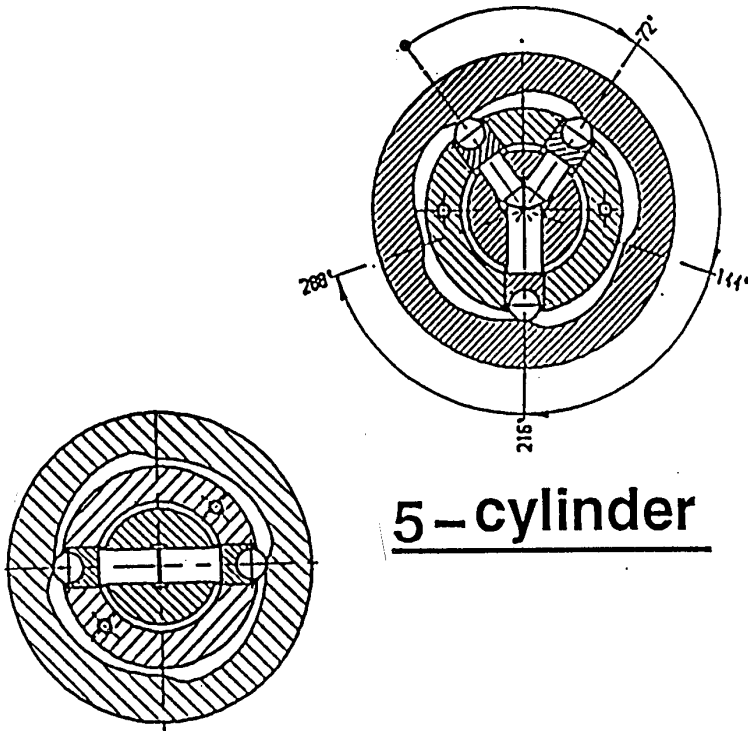

5-cylinder

4- and 6-cylinder

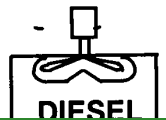
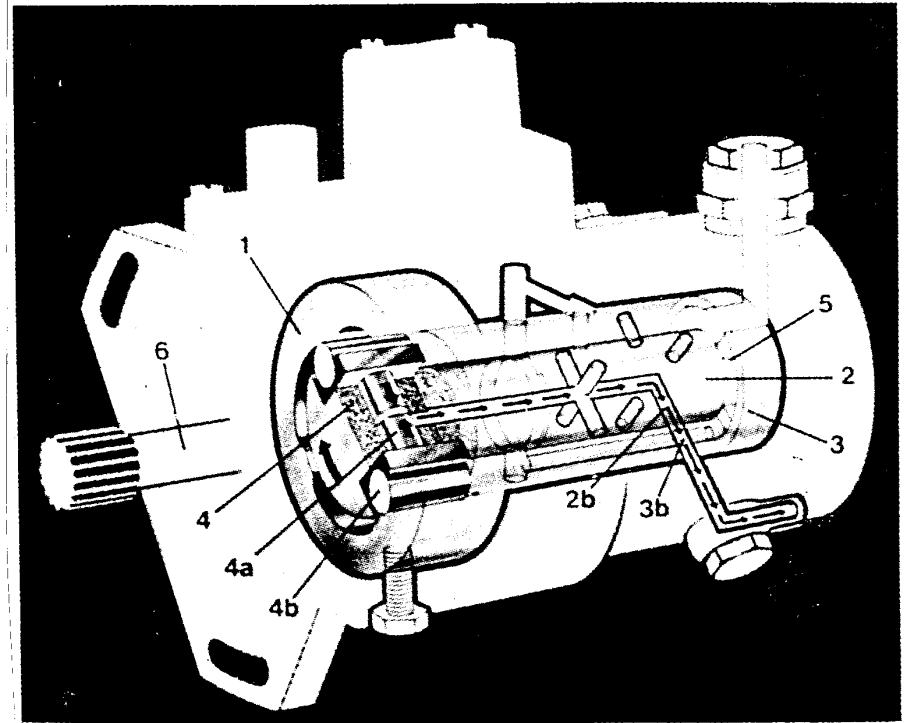

# FUEL INJECTION SYSTEM FOR DIESEL ENGINE

- Electronic Distributor Pump

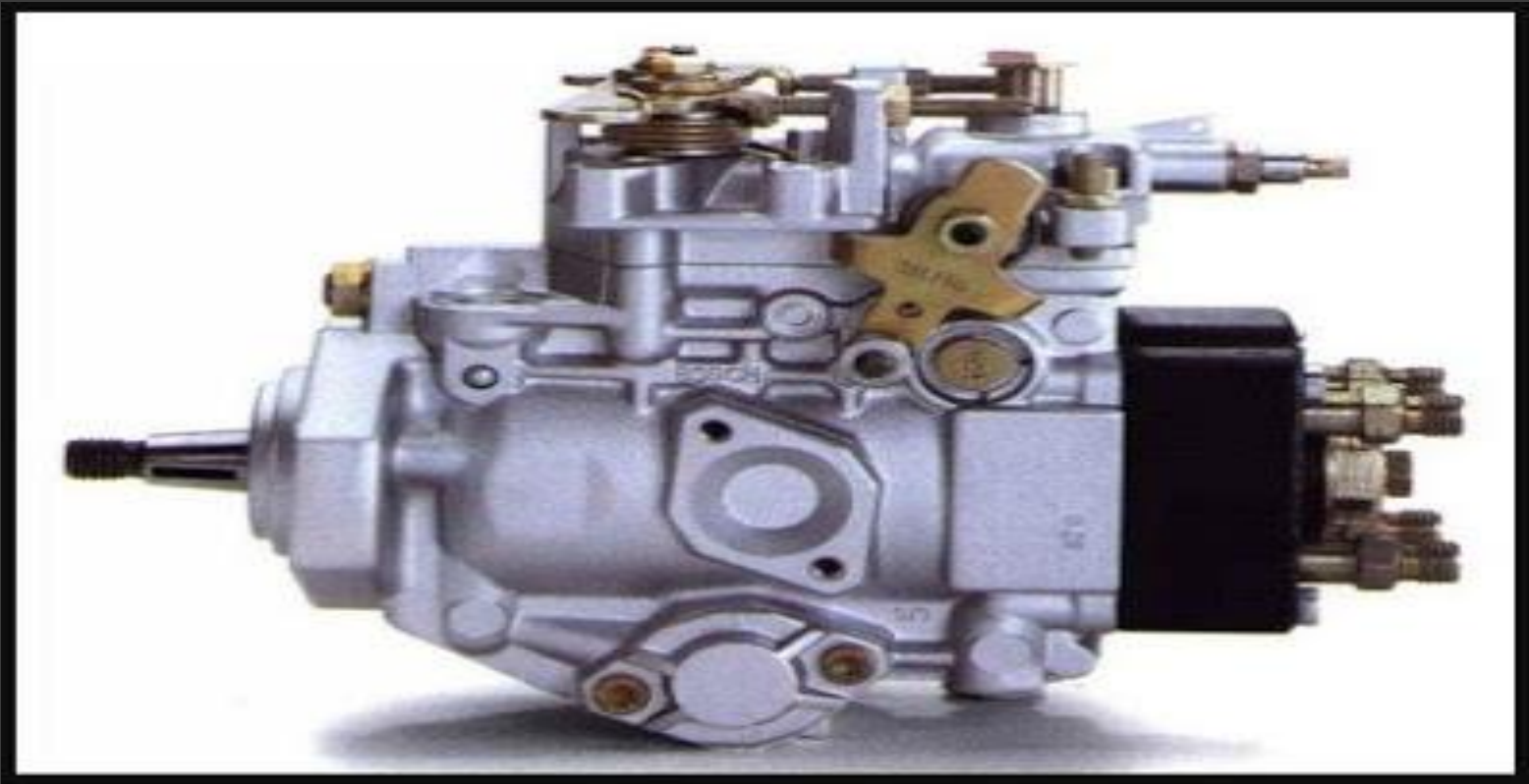

# FUEL INJECTION SYSTEM FOR DIESEL ENGINE

- ⦿ Distributor pump is a type of injection pump with smaller design. The main purpose of the distributor pump, as a solution for vehicles with limited space.
- ⦿ The main feature of the distributor pump is the injection system. The inline type uses one plunger for one injector, but the distributor type uses a single plunger for all injectors.
- ⦿ The way it works, this plunger will press all the fuel in each fuel barrel alternately. The fuel barrel is placed around the pump shaft.



# FUEL INJECTION SYSTEM FOR DIESEL ENGINE

- ◎ When the pump shaft rotates, the plunger will press the fuel in the fuel barrel alternately according to the ignition timing.

Even though it has a smaller design, the distributor pump does not have high fuel pressure. Therefore, this type is rarely used for high capacity diesel engines.

# FUEL INJECTION SYSTEM FOR DIESEL ENGINE

## ● Electronic Unit Injector (EUI)

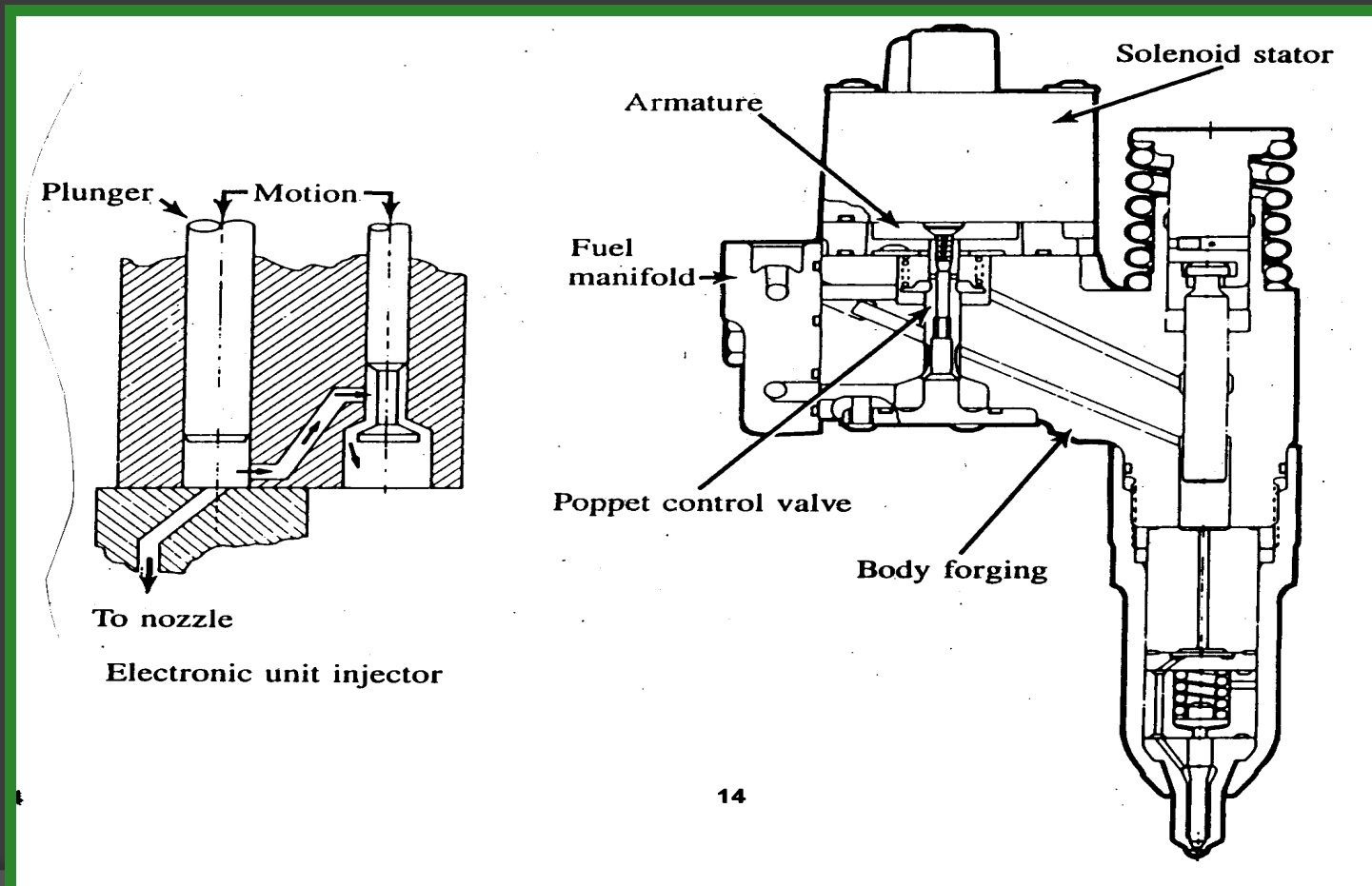

# FUEL INJECTION SYSTEM FOR DIESEL ENGINE

- Electronic Unit Injector (EUI)
- The electronic unit injector is mechanically pressurized using the electronic control of metering, timing, and governing functions. It consists of a range of basic elements, such as the **spring-loaded plunger and barrel** (to pressurize the fuel in the injector), **the poppet valve** (to regulate the pressure build-up), **an electric solenoid** (to actuate movement of the needle or poppet valve fuel inlet), **return passageways** (to get an efficient flow of fuel) and **the nozzle valve** (to enhance atomization).

# FUEL INJECTION SYSTEM FOR DIESEL ENGINE

- ◎ Electronic Unit Injector (EUI)
- ◎ In a unit injection system, the nozzle and injection pump are integrated into one module. Thus, fuel pressurization, atomization, fuel distribution, and injection timing are accomplished in just one component. An electronic unit injector system is installed directly into a cylinder head over every combustion chamber. An engine camshaft drives the injector typically through the rocker lever, resulting in an efficient mechanical and hydraulic fuel system. Fuel droplet sizes are smaller for enhanced emissions, and this finer atomization enables EGR flow tolerance into combustion mixtures.

# FUEL INJECTION SYSTEM FOR DIESEL ENGINE

## ● High-Pressure Common Rail

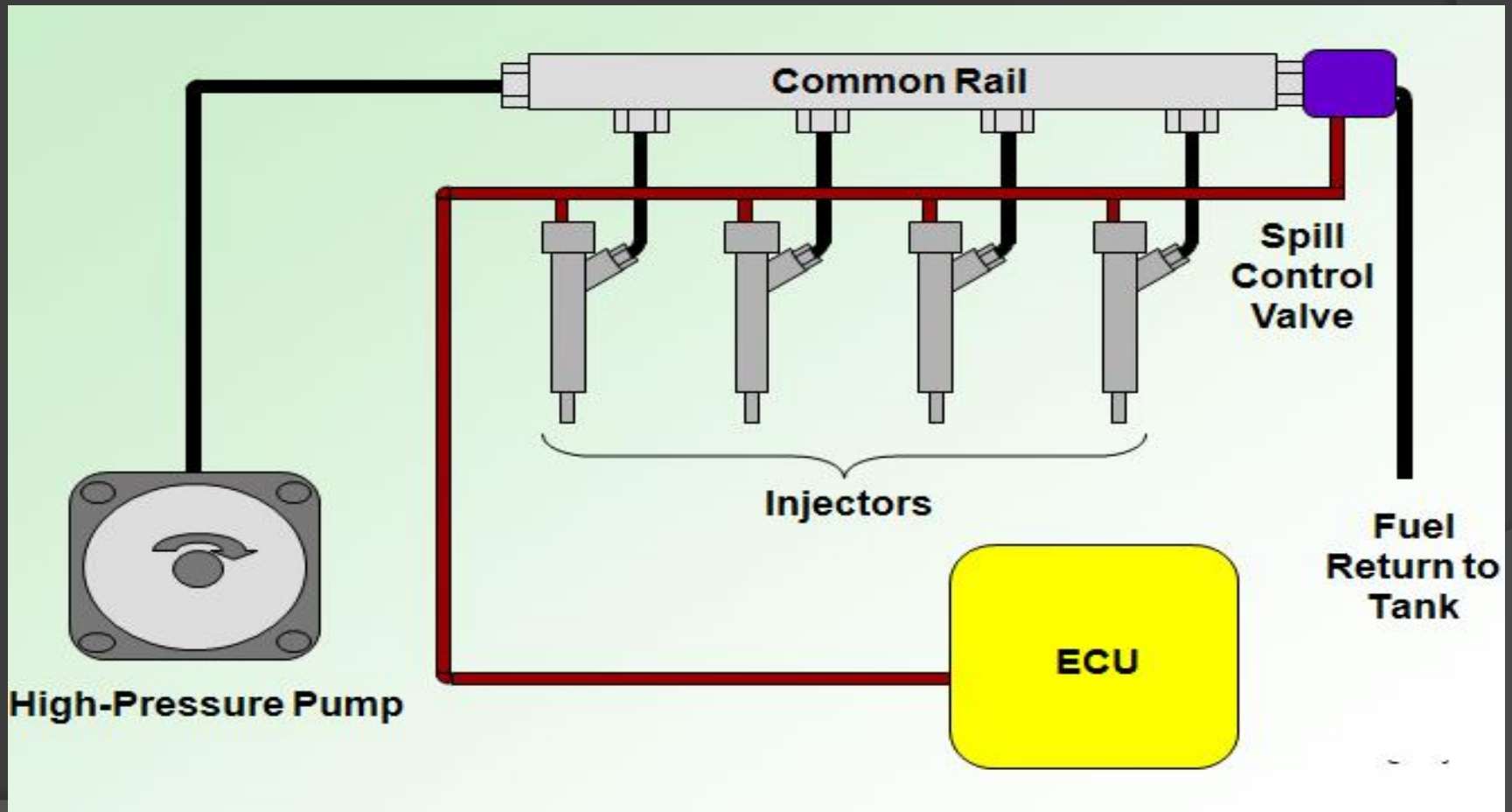

# COMMON RAIL FUEL INJECTION SYSTEM AND ITS FUNCTION

**D  
I  
E  
S  
E  
L  
E  
N  
G  
I  
N  
E**

- Provide the diesel engine with fuel
- **Generate the high pressure** needed for fuel injection and distribute the fuel to the individual cylinders
- **Inject precisely correct amount of fuel** at exactly the right moment in time.
- In contrast to other injection system Common rail fuel injection system is an accumulator injection system.

# HOW DOES A CR SYSTEM FUNCTION?

## Sub functions of a CRFI system

**COMMON RAIL FUEL INJECTION SYSTEM**

```
graph TD; A[COMMON RAIL FUEL INJECTION SYSTEM] --- B[Low pressure circuit]; A --- C[High pressure circuit]; A --- D[ECU with sensors]
```

Low pressure circuit

High pressure circuit

ECU with sensors

# THE COMMON RAIL SUB FUNCTIONS

- Low –pressure circuit comprises of:  
Fuel tank ,Pre-supply pump, Fuel filter,  
And the respective connection lines.

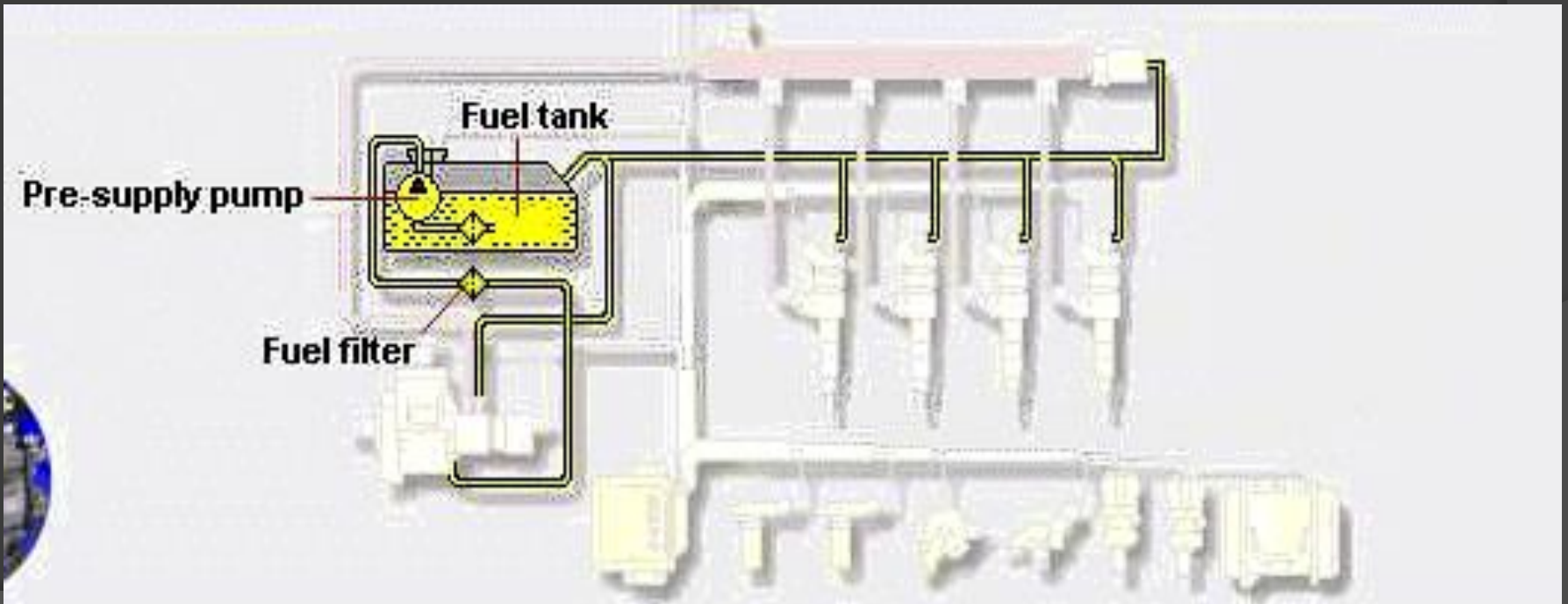



# LOW –PRESSURE CIRCUIT

- The low –pressure circuit is responsible for transporting the fuel to the high –pressure circuit.

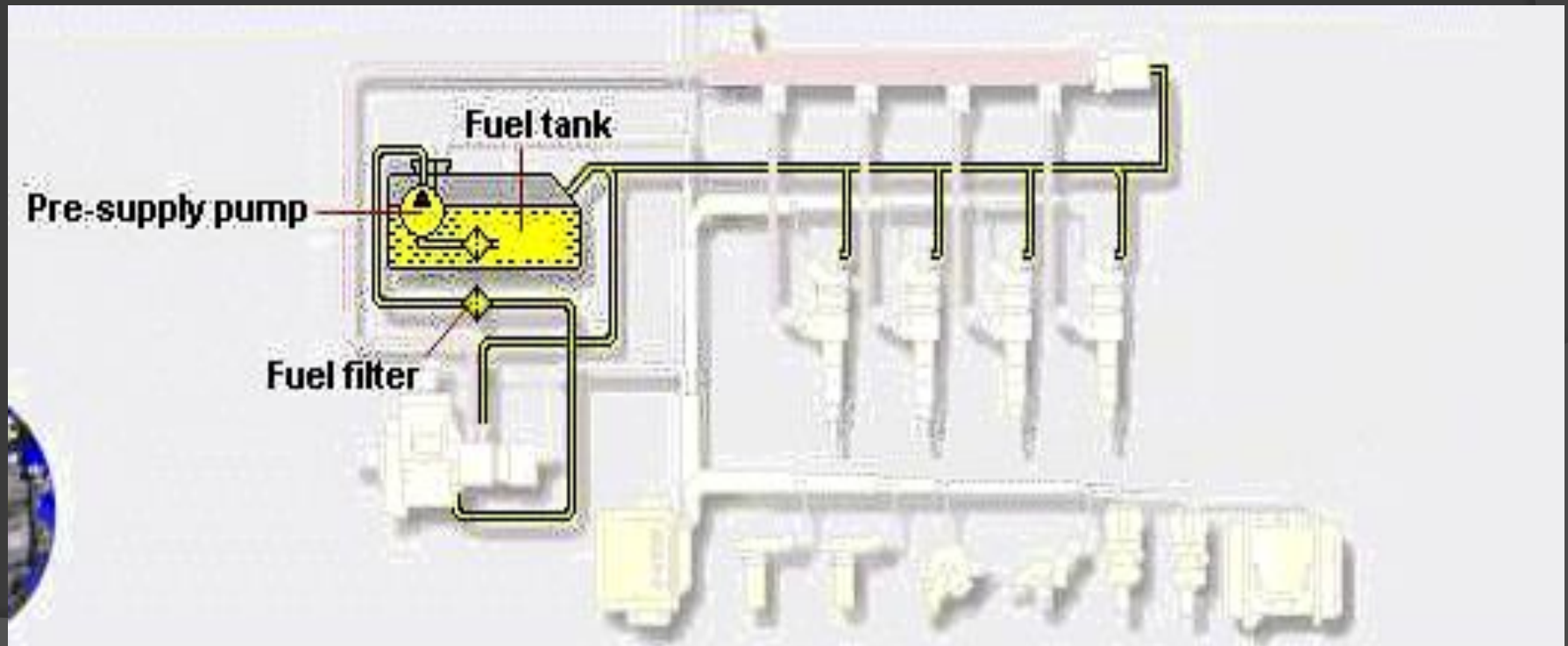

# THE COMMON RAIL SUB FUNCTIONS

High –pressure circuit comprises:

- High – pressure pump with pressure – control valve
- The high – pressure accumulator (Rail )with the rail –pressure sensor
- Injectors, and
- The respective high – pressure connection lines.

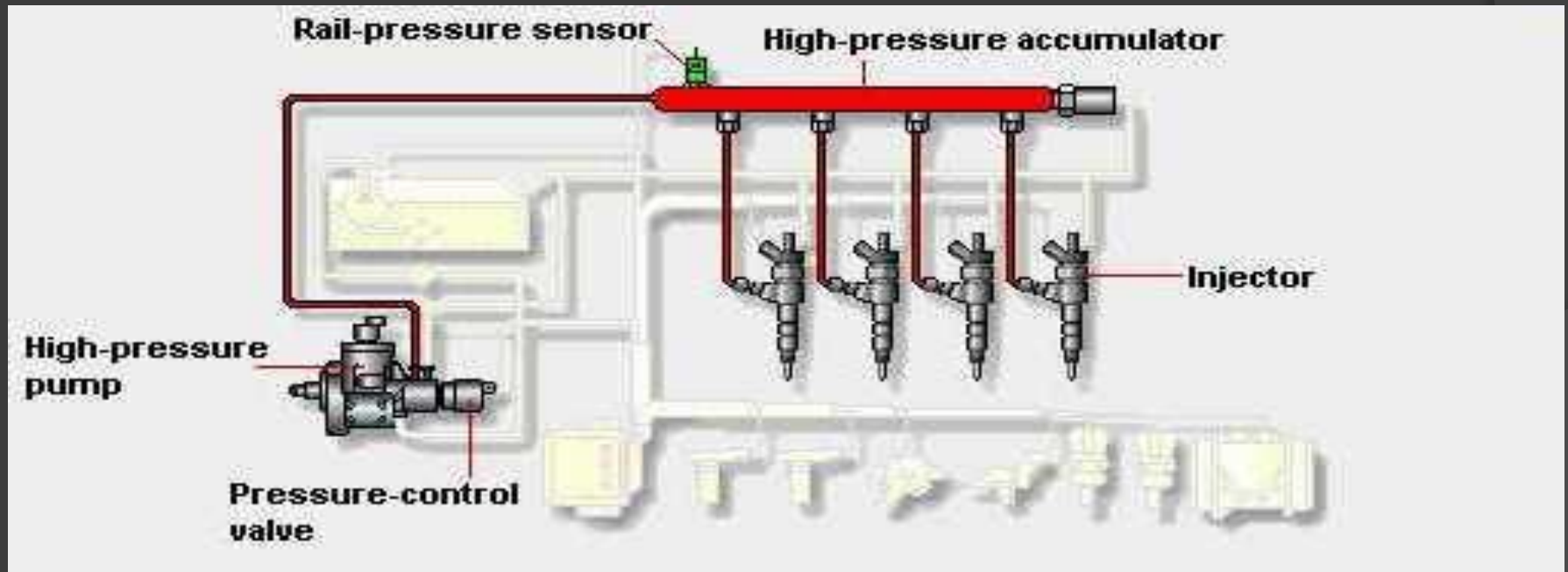

# THE HIGH – PRESSURE CIRCUIT

It is the responsibility of the high pressure circuit to generate a constant unvarying high pressure in the high pressure accumulator (the rail) and to inject the fuel through the injectors into the engine's combustion chambers.

# THE COMMON RAIL SUB FUNCTIONS

- ⦿ ECU and sensors
- ⦿ The common rail ECU evaluates the signals from the following sensors.
- ⦿ Crankshaft – speed sensor, Camshaft sensor,
- ⦿ Accelerator-pedal travel sensor

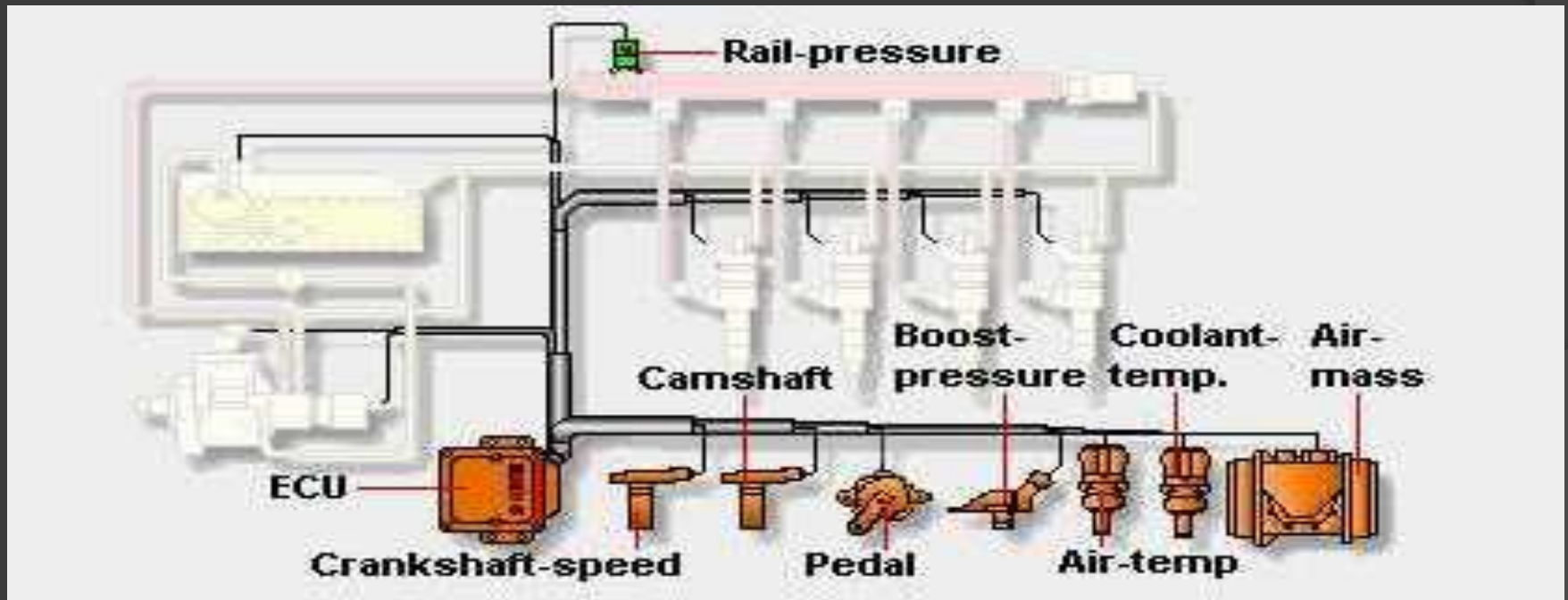

# THE COMMON RAIL SUB FUNCTIONS

- The common rail ECU evaluates the signals from the following sensors:
- Boost – pressure sensor, Air temperature sensor,
- Air – mass meter, and Rail pressure sensor.

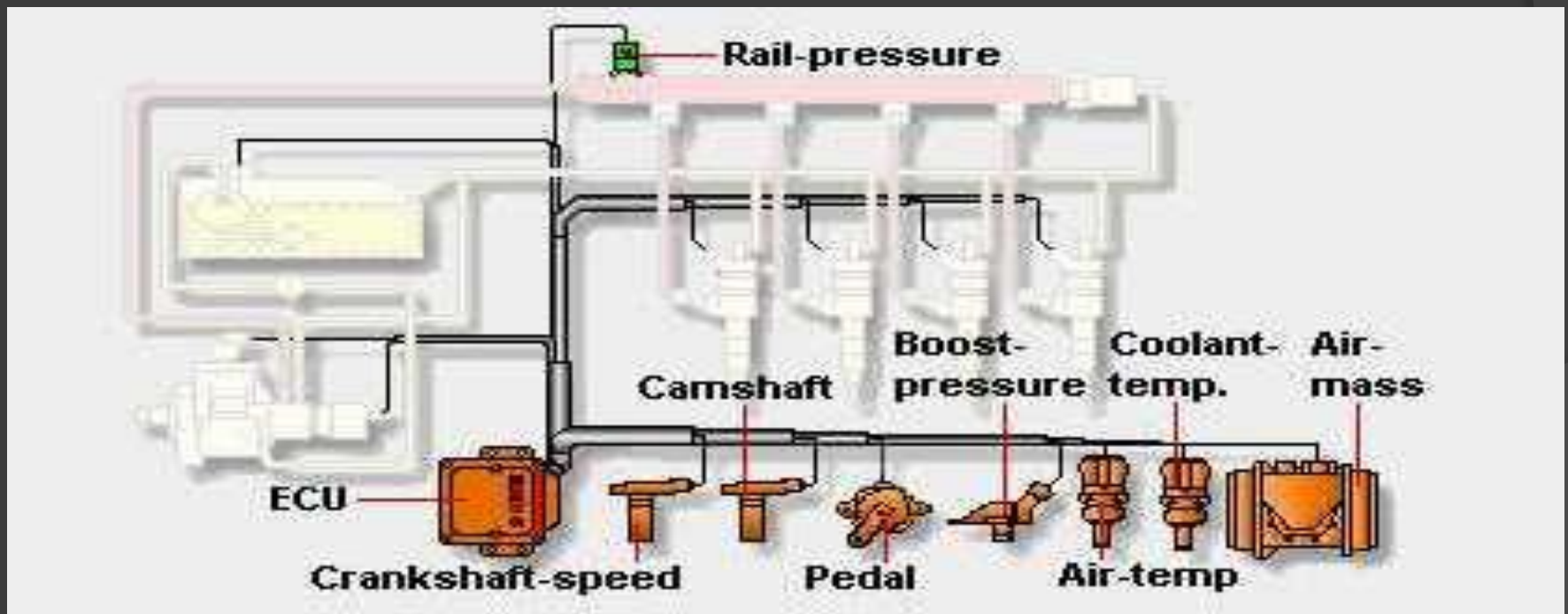

# THE COMMON RAIL SUB FUNCTIONS

- ECU and sensors
- The sensors are responsible for measuring important physical quantities. The ECU calculates injected fuel quantity, start of injection, duration of injection, and rate of discharge curve, as well as supervises the correct functioning of the injection system as a whole.

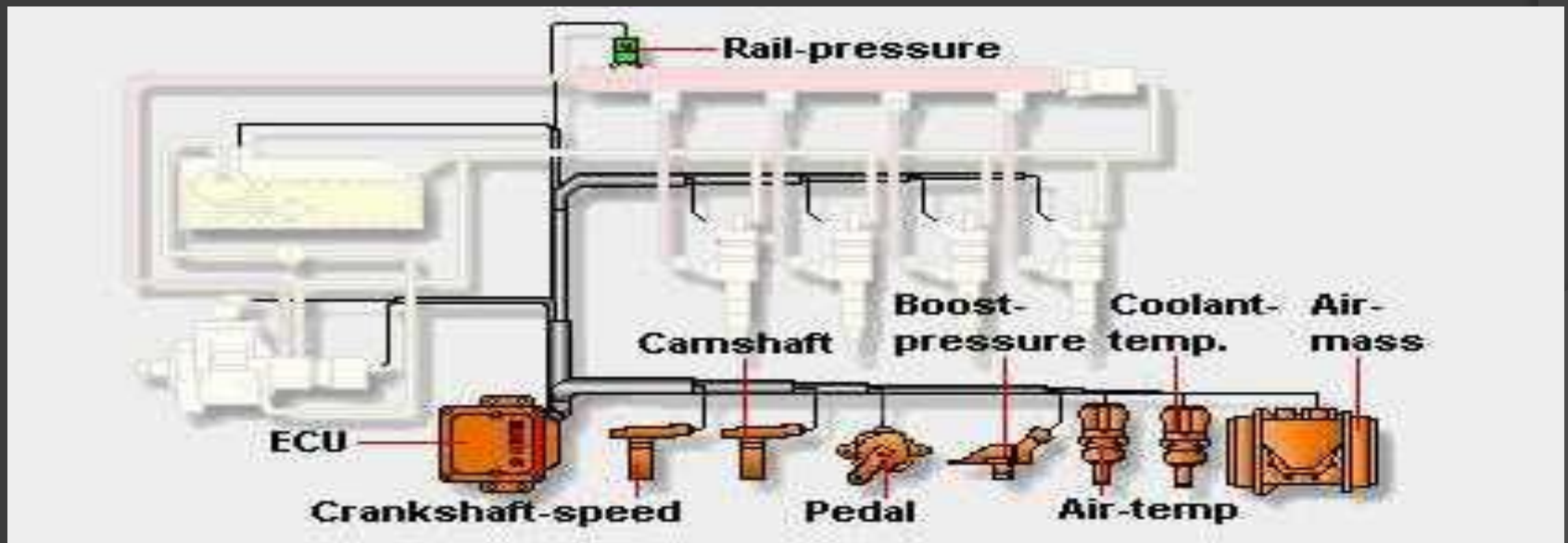

# COMMON RAIL FUEL INJECTION SYSTEM

## DESIGN

### PRE SUPPLY PUMP

- ⦿ Transports fuel from the fuel tank to the high pressure pump.
- ⦿ An electric fuel pump is used for this purpose in the CRFIS (common rail fuel injection system).
- ⦿ When the electric fuel pump is switched off, the supply of fuel is interrupted and the engine stops.

# PRE SUPPLY PUMP

The electric fuel pump comprises of:

1. Electric Motor
2. Roller-Cell Pump
3. Non Return Valve

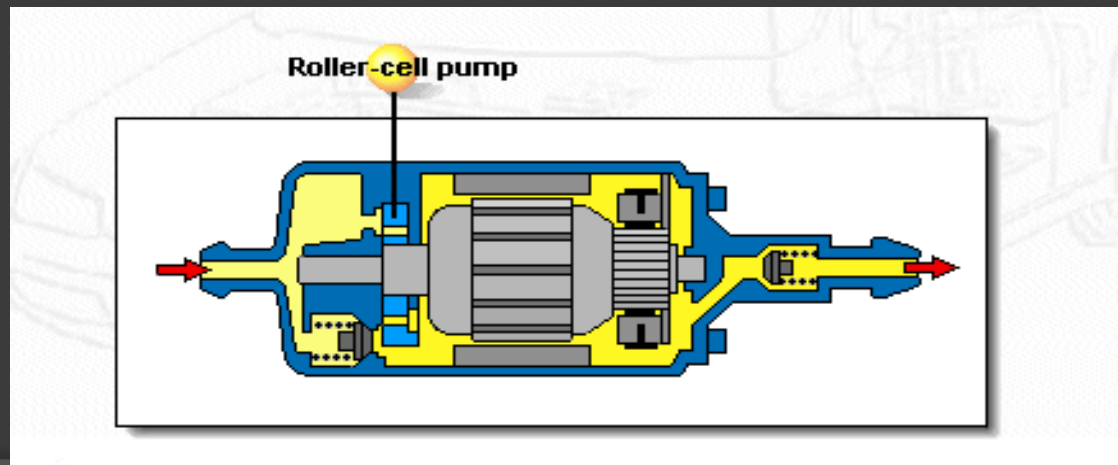



# PRE SUPPLY PUMP

- ⦿ The roller cell is driven by an electric motor.
- ⦿ Its rotor is mounted eccentrically and provided with slots in which movable rollers are free to travel.

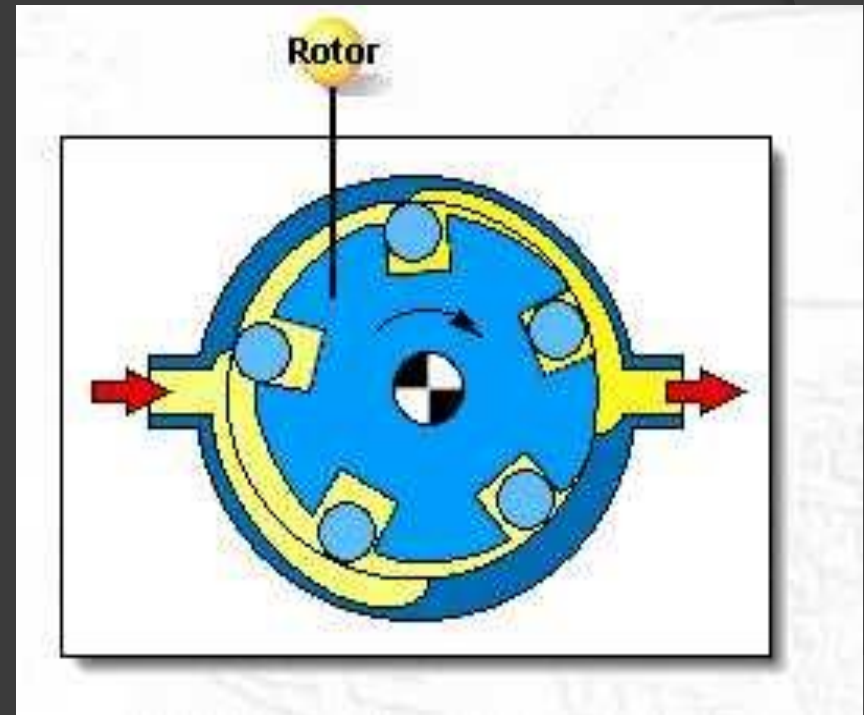

# PRE SUPPLY PUMP

- ⦿ The rollers are forced against the base plate by rotation and by fuel pressure .
- ⦿ The fuel is transported to the outlet openings on the pump's pressure side.

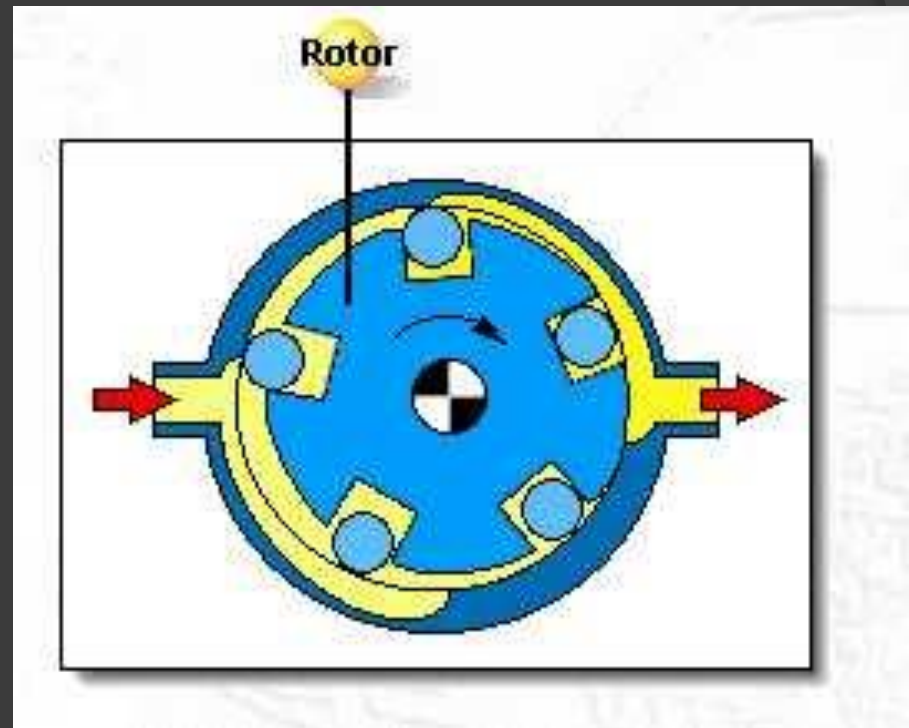

# PRE SUPPLY PUMP VARIANTS

- ⦿ Gear type fuel pump
- ⦿ The drive gear wheel is driven by the engine.
- ⦿ Delivery quantity is directly proportional to engine speed.
- ⦿ Shut off is by means of an electromagnet.

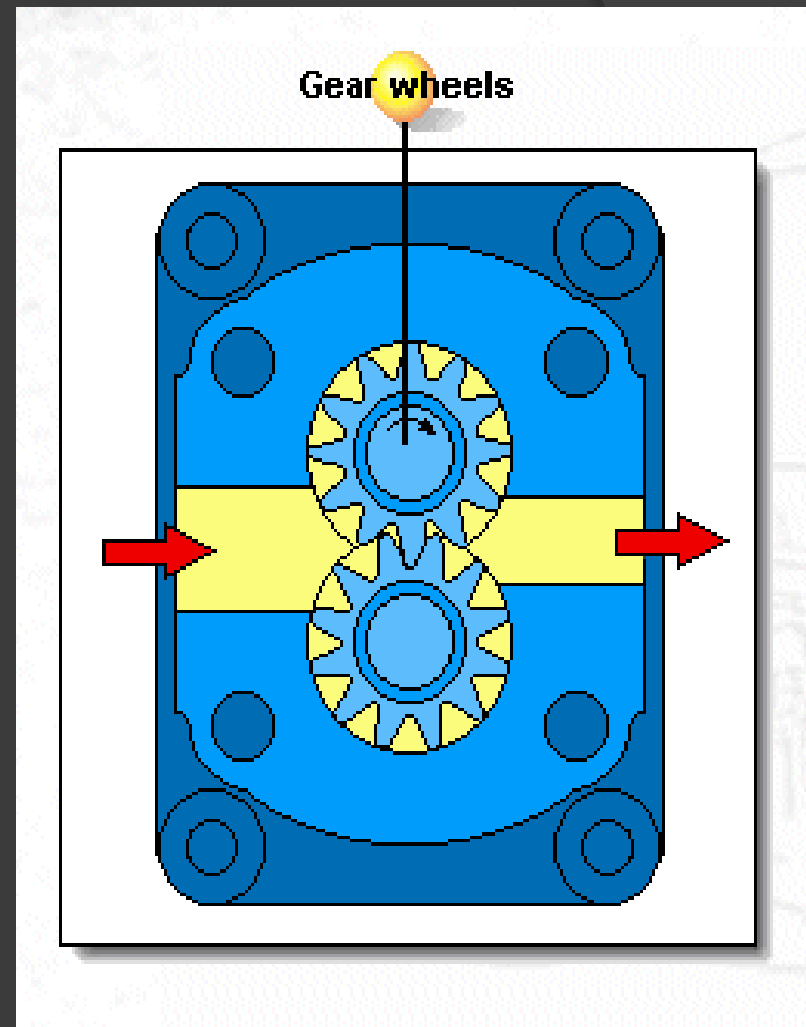

# HIGH-PRESSURE PUMP

- The pump plunger moves downwards
- The inlet valve opens
- The fuel is drawn in to the pumping element chamber(suction stroke)

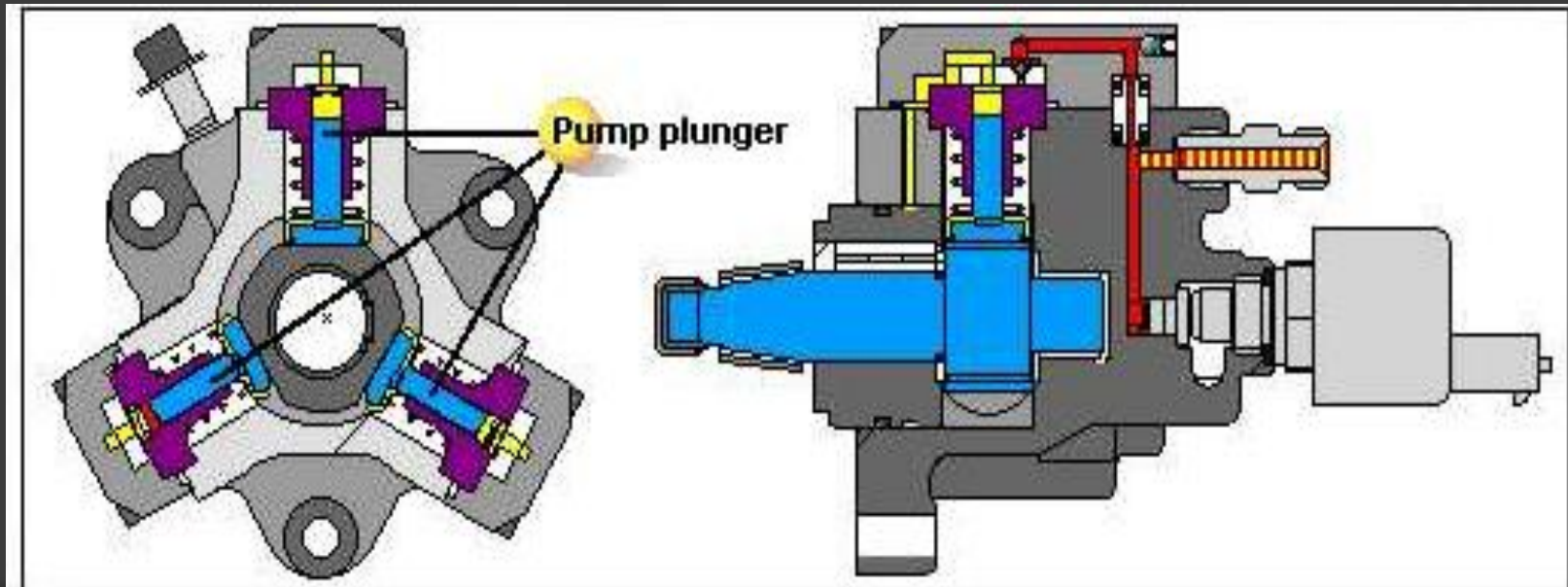

# HIGH-PRESSURE PUMP

- At BDC, the inlet valve closes
- The fuel in the chamber can be compressed by the upward moving plunger.

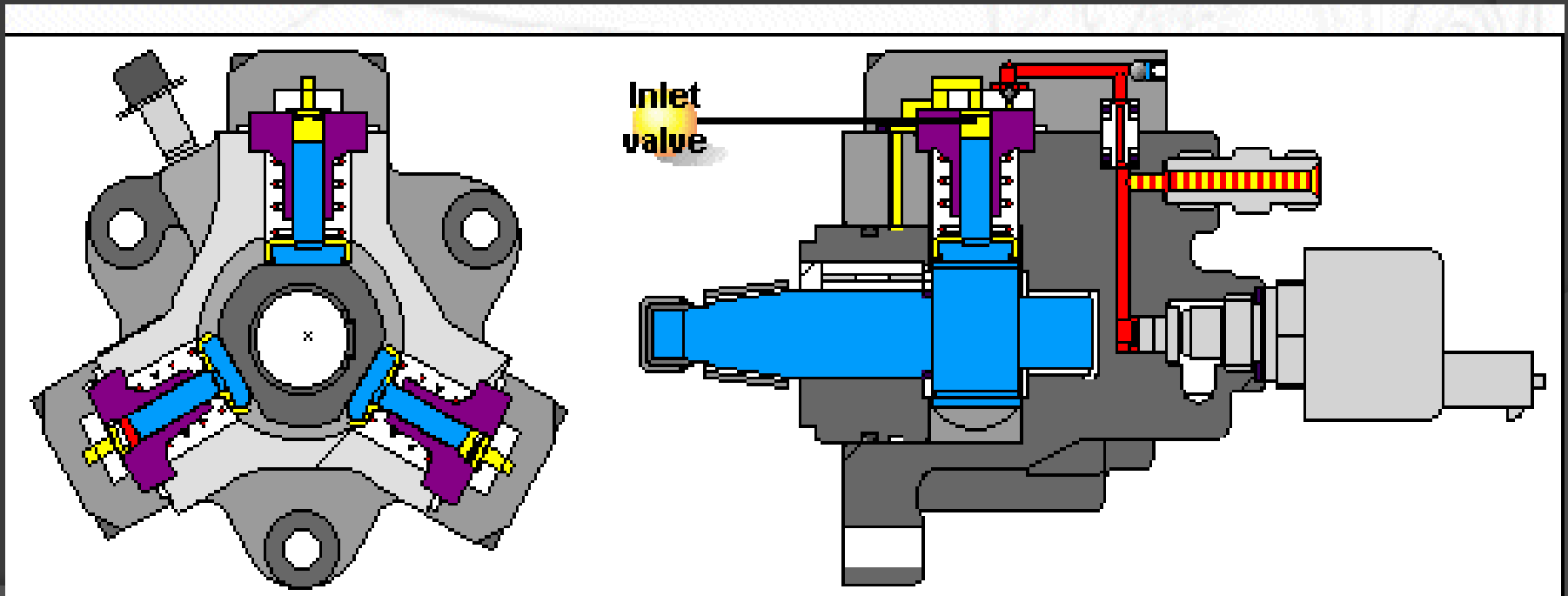

# HIGH-PRESSURE PUMP

- An electromagnet is used for pumping element switch-off.

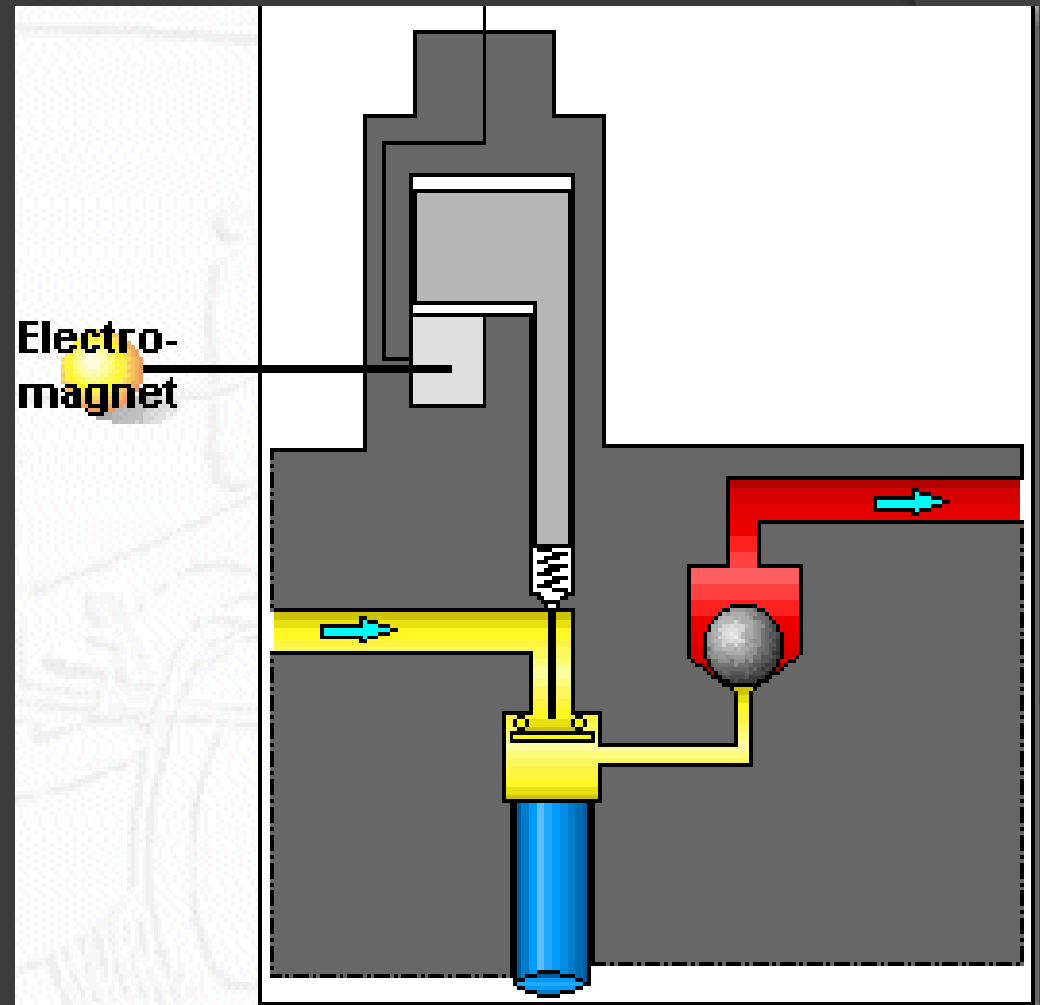

# RAIL-PRESSURE SENSOR (RDS)

- ⦿ Measures the pressure in the rail
- ⦿ inputs the information to the ECU
- ⦿ **RDS should provide extremely precise measured values.**
- ⦿ **RDS is mounted directly on the rail.**

# INJECTOR

- Injects exactly the correct amount of fuel in to the combustion chamber at precisely the right moment in time



# INJECTOR

The injector is equipped with:

- 2/2 electromagnetic servo valve
- Nozzle
- Valve control chamber
- Return line



KMP -Video File

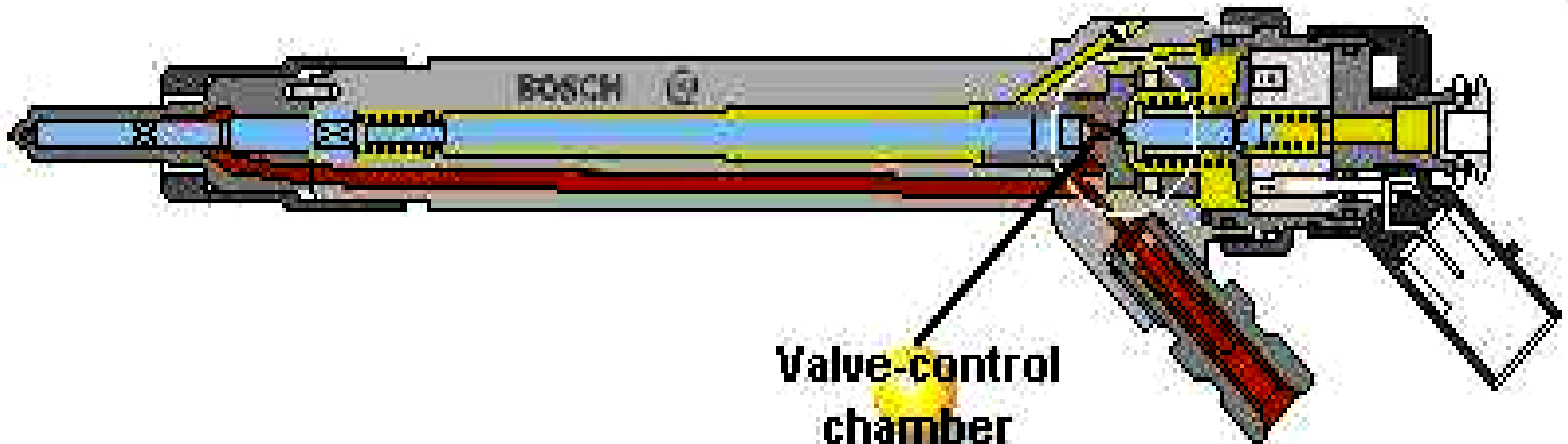

# INJECTOR

The essential forces for correct functioning are:

- ◆ Nozzle-spring force
- ◆ Valve spring force
- ◆ Electromagnet force
- ◆ Force due to the pressure in the valve-control chamber
- ◆ Force due to the pressure in the nozzle needle

# COMMON RAIL FUEL INJECTION SYSTEM SUMMARY

Components of CRFIS are:

- Pre-supply pump
- High-pressure pump
- High-pressure accumulator(rail)
- Pressure-control valve
- Rail-pressure sensor
- Injectors

# A DUAL FUEL CONVERSION SYSTEM FOR DIESEL ENGINES

- ◎ Dual fuel systems, engines that operate on more than one fuel source, are gaining popularity because they reduce the amount of diesel fuel used.
- ◎ Until recently, adding a dual fuel system was impractical due to the cost of replacing the original engine and the loss of power traditionally associated with these replacement systems.

# A DUAL FUEL CONVERSION SYSTEM FOR DIESEL ENGINES

- ⦿ Energy Conversions, Inc. (ECI), has invented a dual fuel conversion system that easily converts diesel engines into diesel-natural gas engines, eliminating the need for companies to replace their diesel engines with natural gas engines.
- ⦿ The system reduces emissions by allowing engines to operate cleanly on domestically produced natural gas while still maintaining the potential to operate on traditional diesel fuel as well.