



Volumetric Estimation



✦ Introduction

- Volumetric estimation:
 - (1) Quantify how much oil and gas exists
 - (2) Change over time
- Two main methods
 - (1) Deterministic
 - (2) Probabilistic

✦ Deterministic Methods

Well logs, cores, seismic

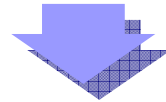

Average the data

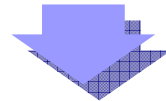

Estimate the field-wide properties

✦ Deterministic Methods

- Formulae to calculate volumes

$$\text{STOIIP} = \text{GRV} \cdot \frac{N}{G} \cdot S_o \cdot \phi \cdot \frac{1}{B_o} [\text{stb}]$$

$$\text{GIIP} = \text{GRV} \cdot \frac{N}{G} \cdot S_g \cdot \phi \cdot \frac{1}{B_g} [\text{stb}]$$

$$\text{Ultimate recovery} = \text{HCIIP} \cdot \text{Recovery factor} [\text{stb}]$$

$$\text{Reserves} = \text{UR} - \text{Cumulative Production} [\text{stb}]$$

✦ Deterministic Methods

✦ The area-depth

- Assume a constant gross thickness (H)
- Known data: structure map, gross thickness
- Measure the respective area
- Plot the area-depth graph

Volumetric Estimation

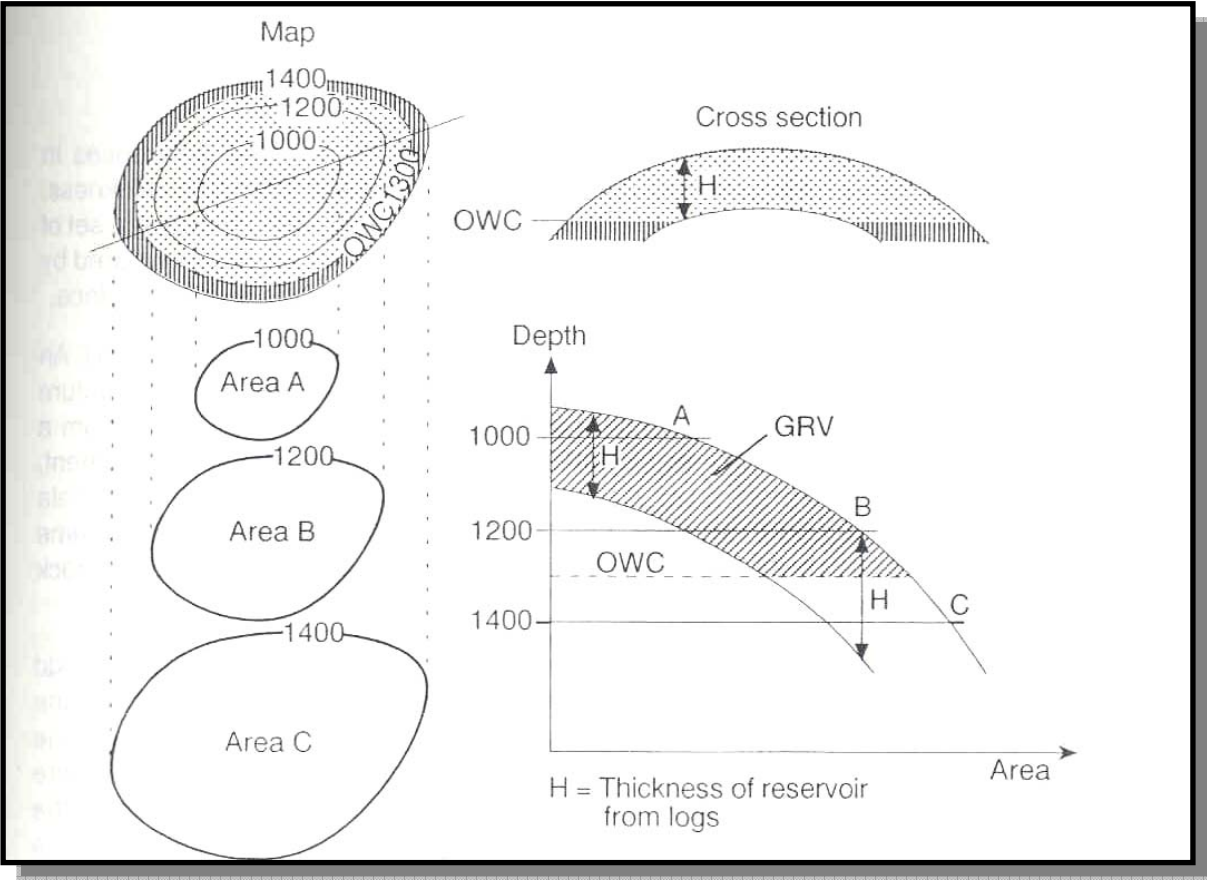

✦ Deterministic Methods

✦ The area-thickness

- Assumption of constant thickness no longer apply
- Known data: structure map, net sand map
- Combines the two maps to find a net oil sand map
- Plot the area-thickness graph

Volumetric Estimation

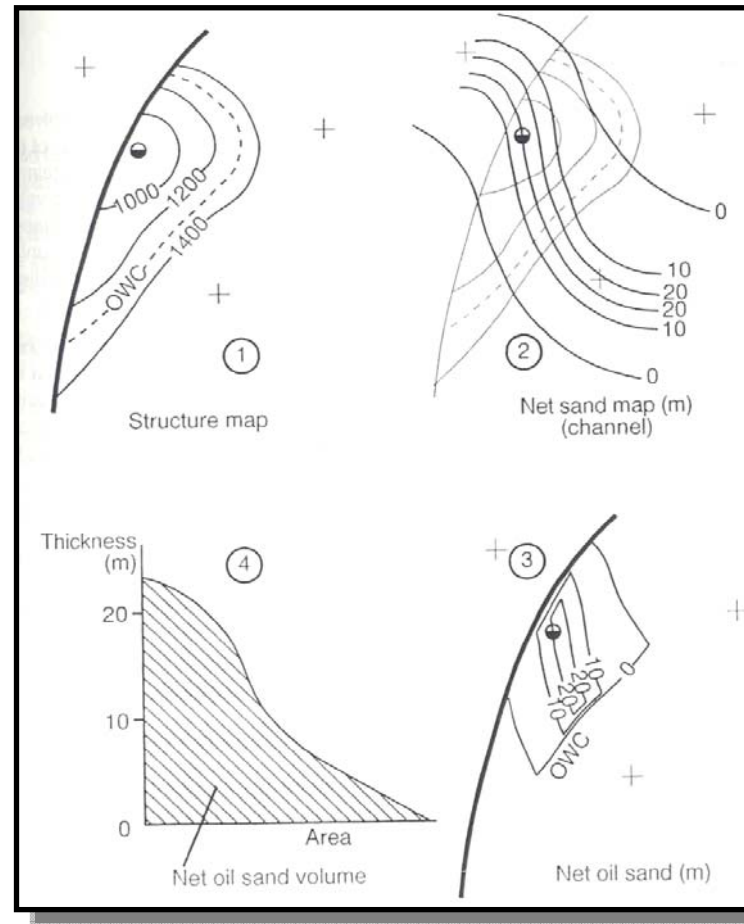

✦ Probabilistic Methods

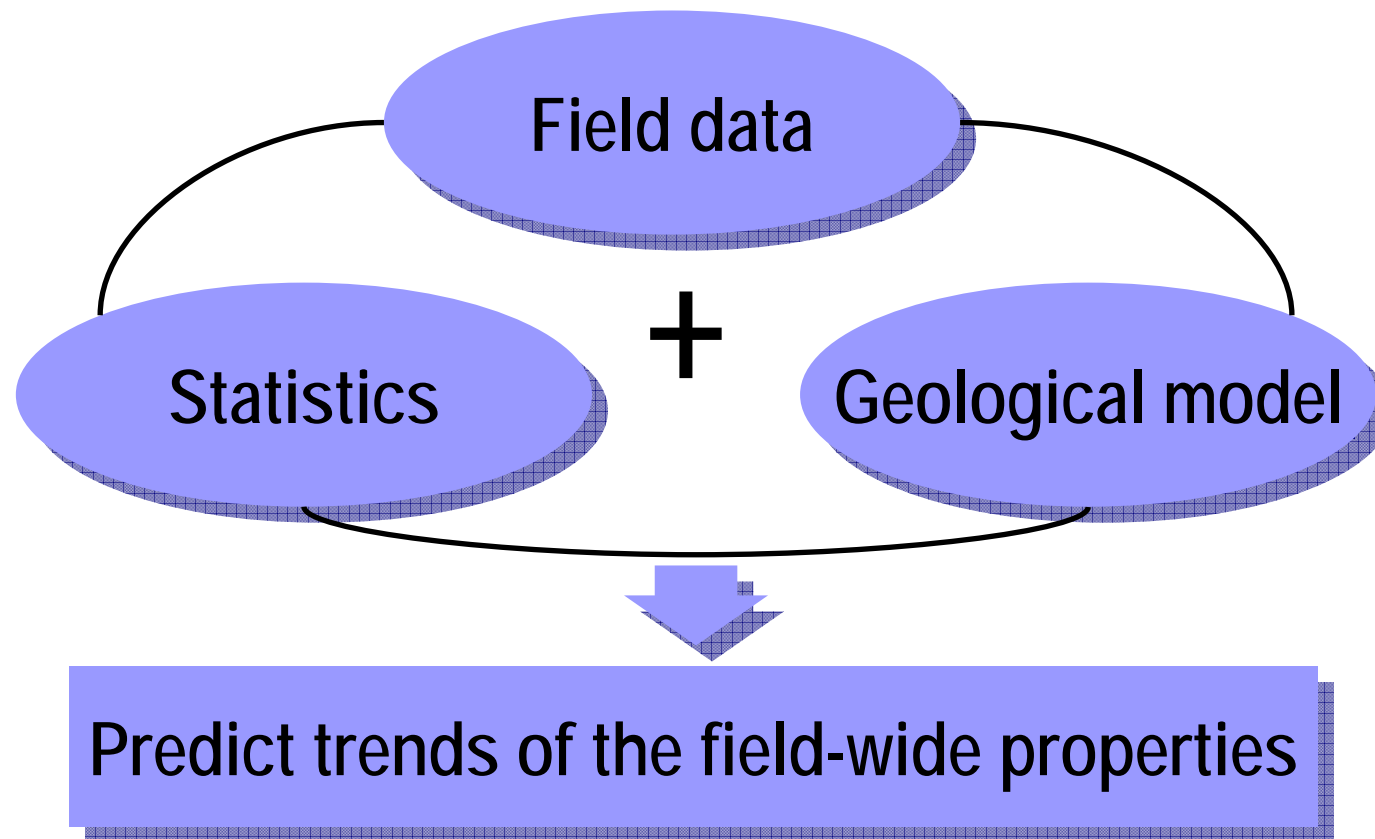

✦ Probabilistic Methods

✦ PDF & Expectation curves

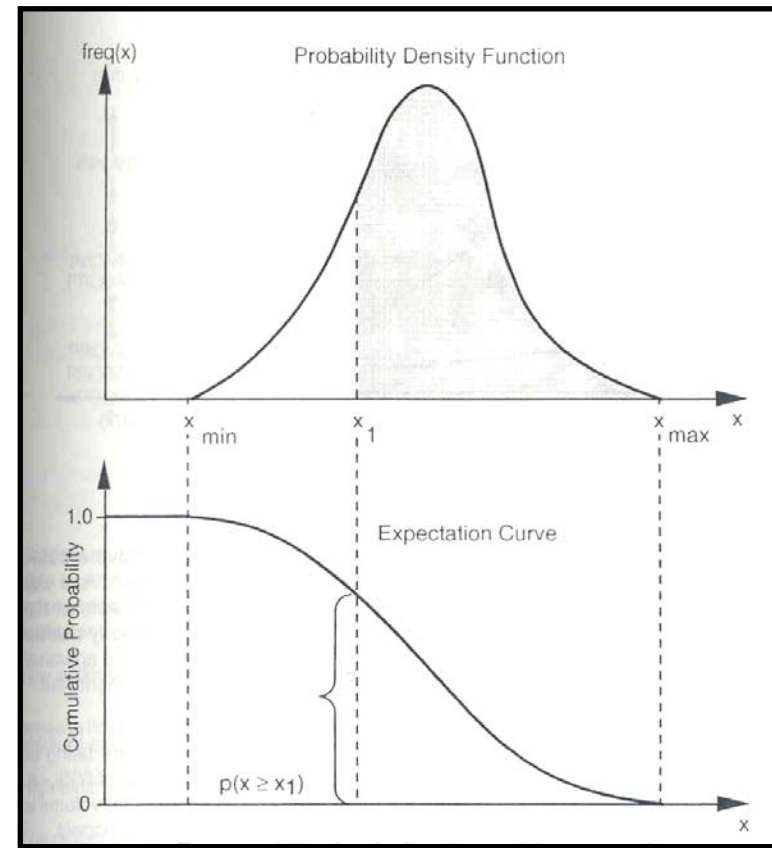
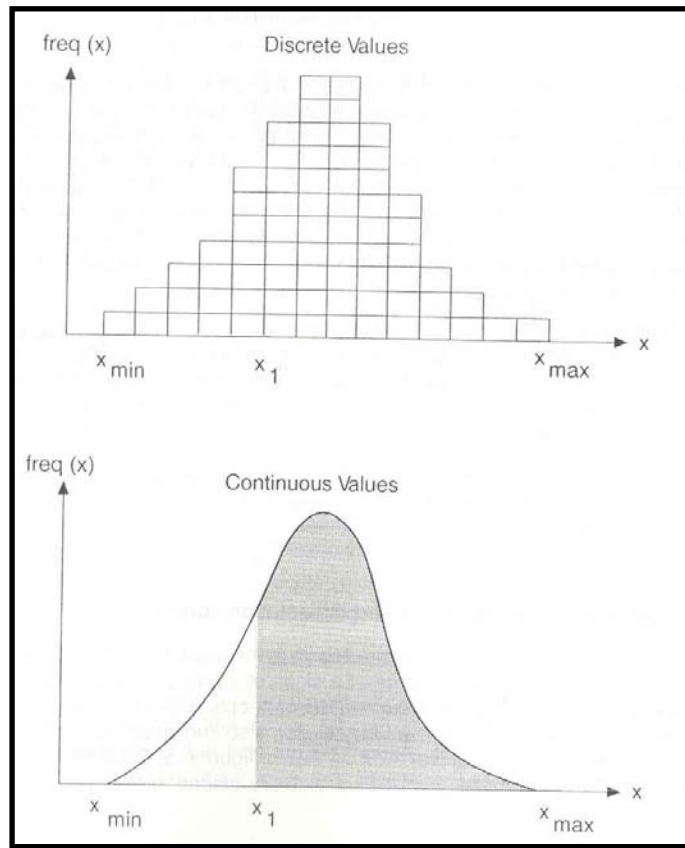

✦ Probabilistic Methods

✦ PDF & Expectation curves

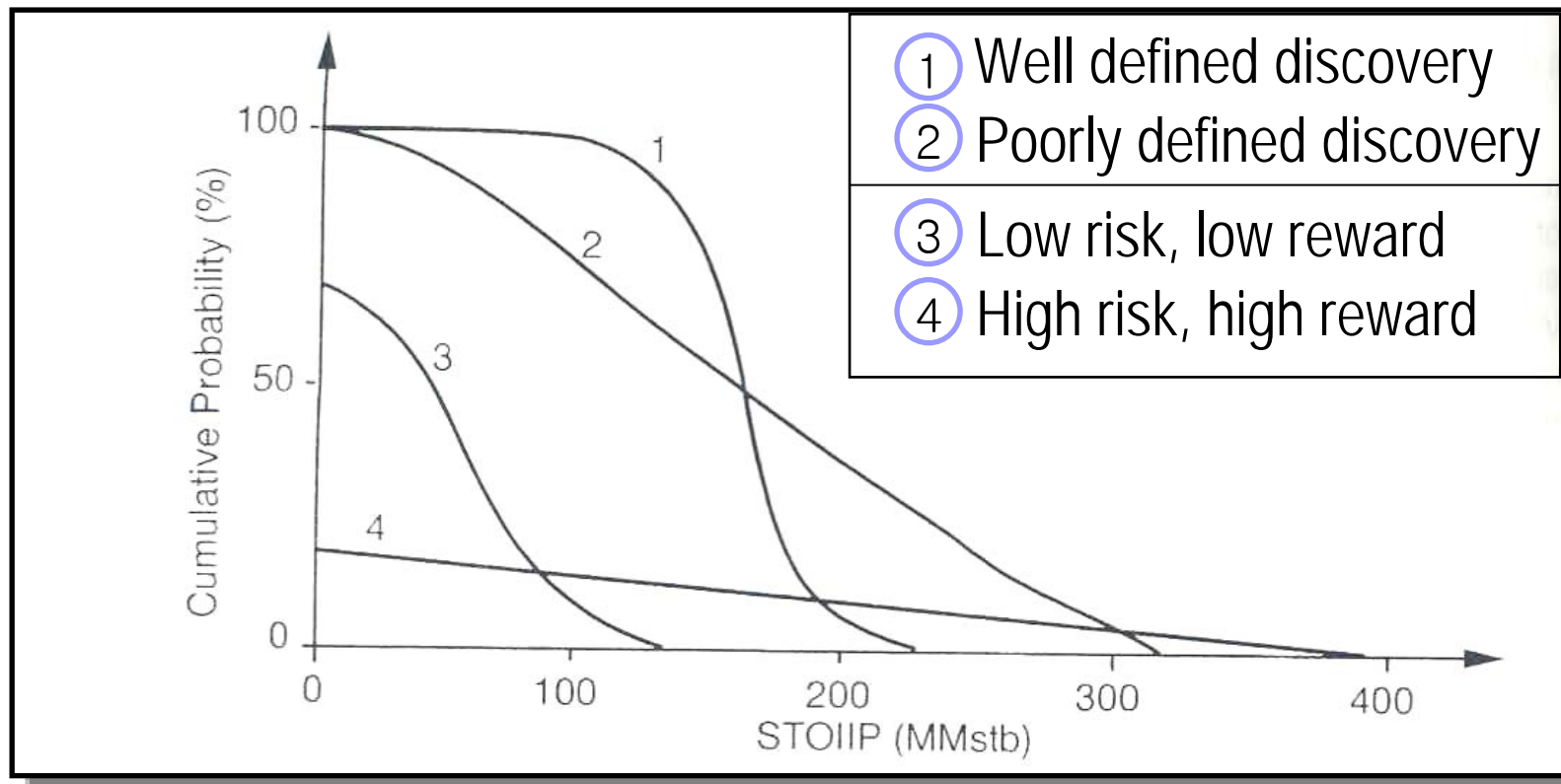

- Expectation curve for a discovery

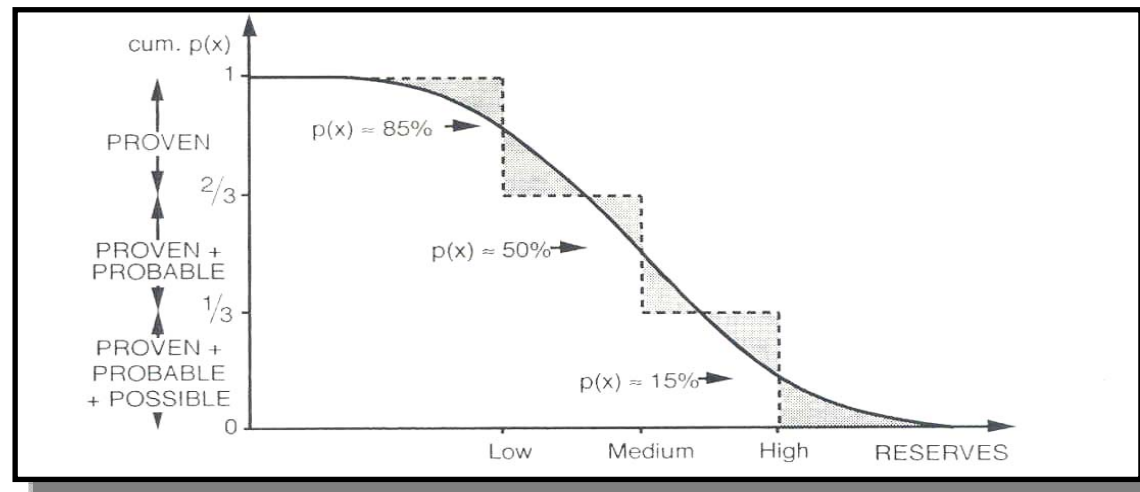

- Low estimate = 85% cumulative probability
- Medium estimate = 50% cumulative probability
- High estimate = 15% cumulative probability
- **Expectation Value = (High+Medium+Low)/3**

- POS (Probability of Success) in exploration step

- (1) A source rock where HC were generated
 - (2) A structure in which the HC might be trapped
 - (3) A seal on top of the structure to stop the HC migrating further
 - (4) A migration path for the HC from source rock to trap
 - (5) The correct sequence of events in time
-

➤ PDF & Expectation curves

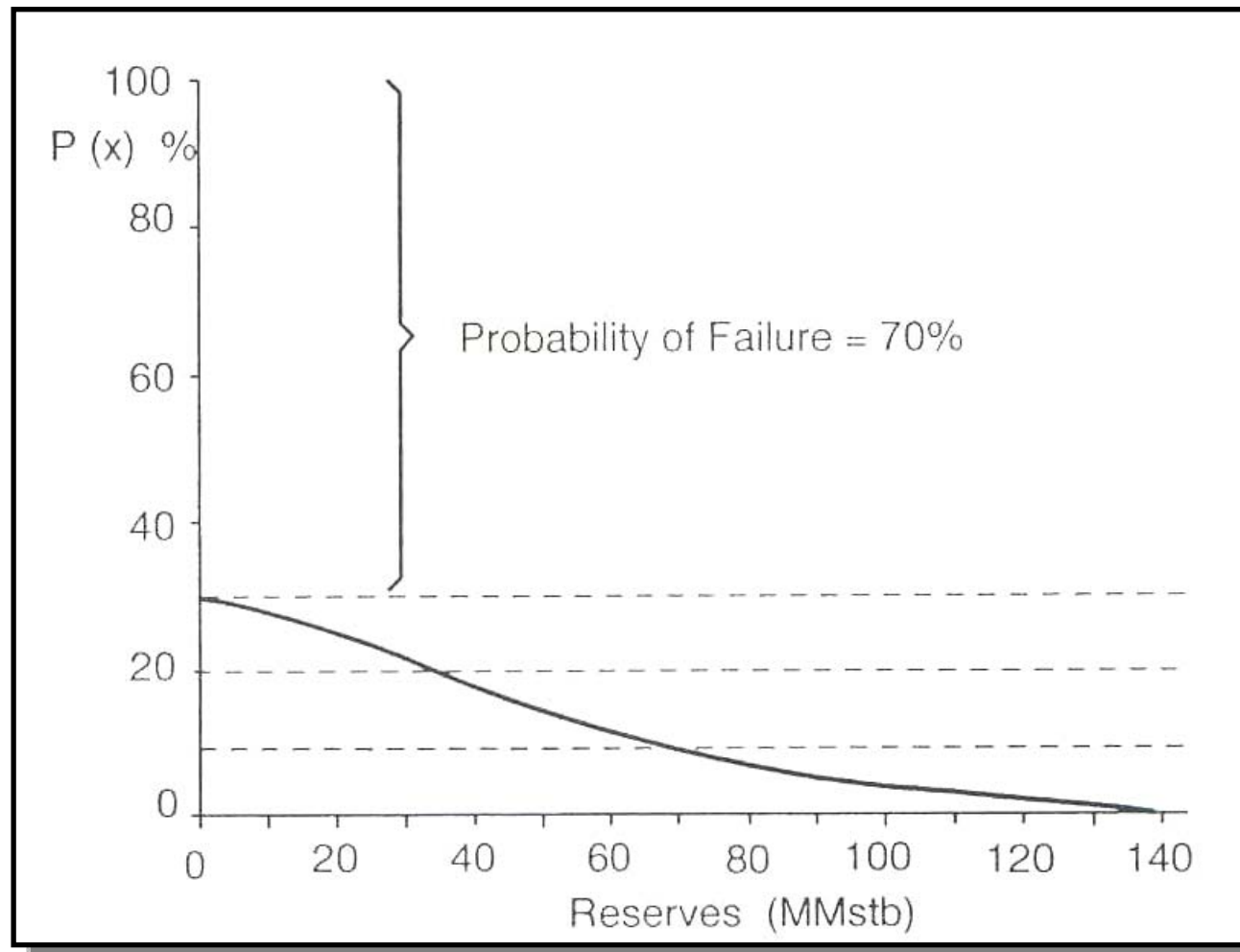

➤ Generating expectation curves

- The Monte Carlo Method

$$UR = \text{area} \cdot \text{thickness} \cdot \frac{N}{G} \cdot \phi \cdot S_o \cdot \frac{1}{B_o} \cdot RF \text{ [stb]}$$

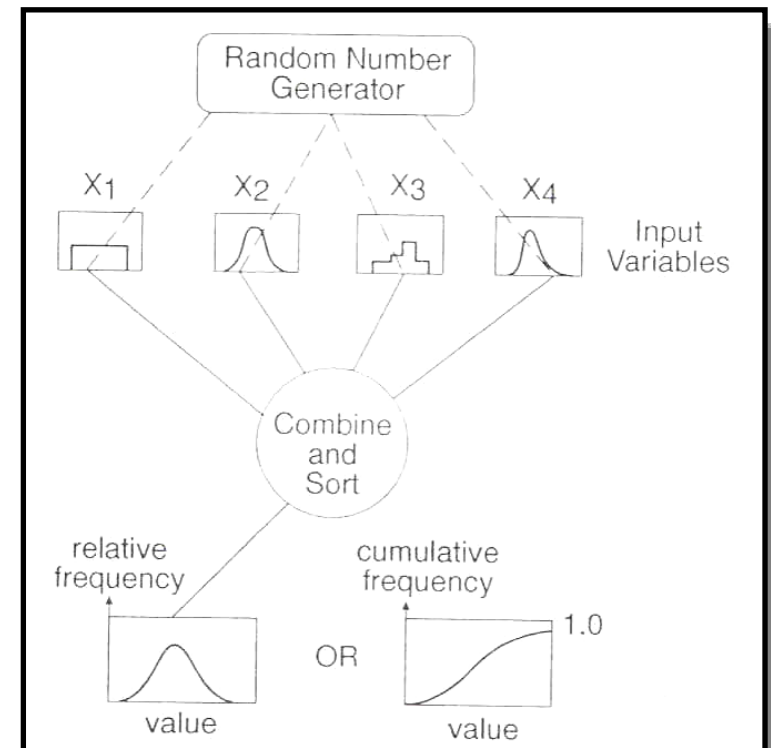
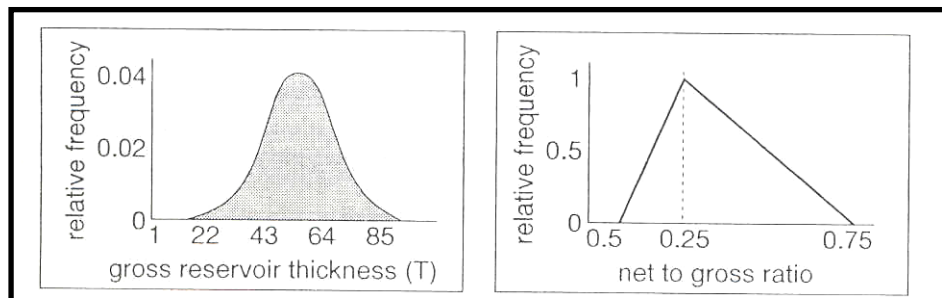

➤ Generating expectation curves

- Parametric method

Lognormal distribution
with calculating K, μ, σ

$$\mu_c = \mu_a \cdot \mu_b, \mu : \text{mean}$$

$$(1 + K_c^2) = (1 + K_a^2) \cdot (1 + K_b^2)$$

$$K = \frac{\sigma}{\mu}, \text{coefficient of variation}$$

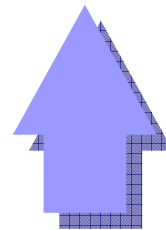

$$UR = \text{area} \cdot \text{thickness} \cdot \frac{N}{G} \cdot \phi \cdot S_o \cdot \frac{1}{B_o} \cdot RF \text{ [stb]}$$

...

➤ Generating expectation curves

- Parametric method:

$(1+K_i^2)$ will be greater than 1.0; the higher the value, the more the variable contributes to the uncertainty in the results

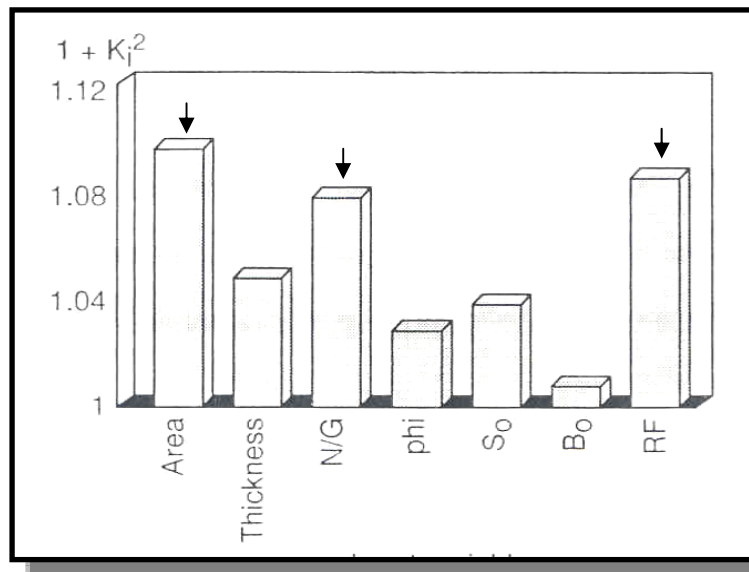

↓ : must be cared to reduce the uncertainty in the results

Generating expectation curves

- Three points method
$$UR = \text{area} \cdot \text{thickness} \cdot \frac{N}{G} \cdot \phi \cdot S_o \cdot \frac{1}{B_o} \cdot RF [\text{stb}]$$

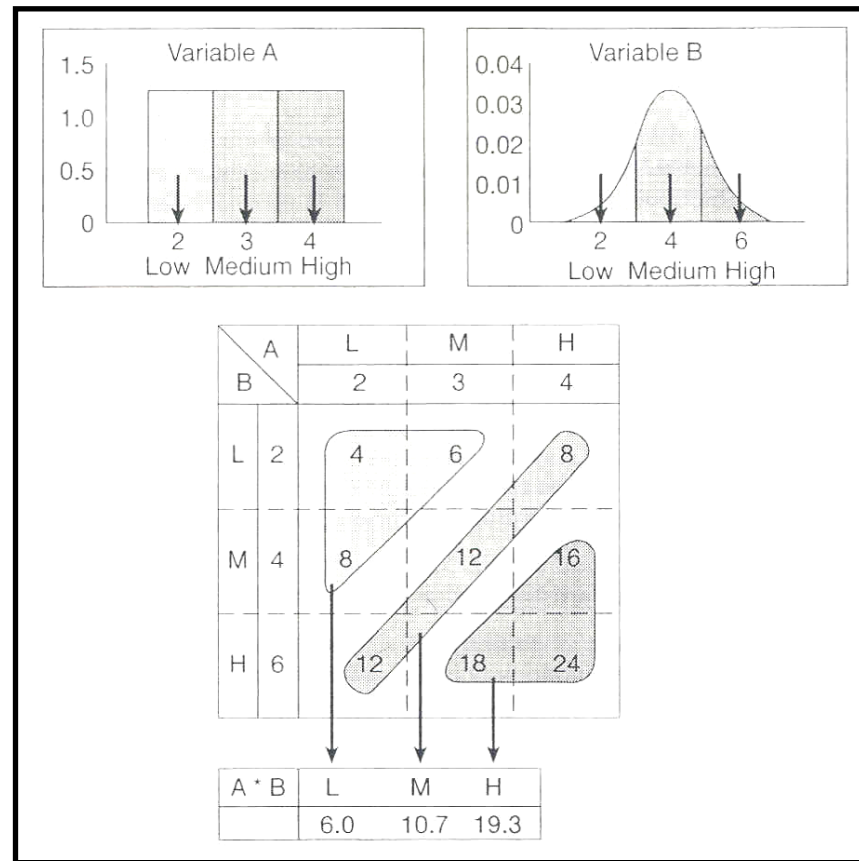

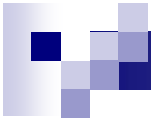

Field Appraisal



✦ Role of appraisal

- Cost effectiveness

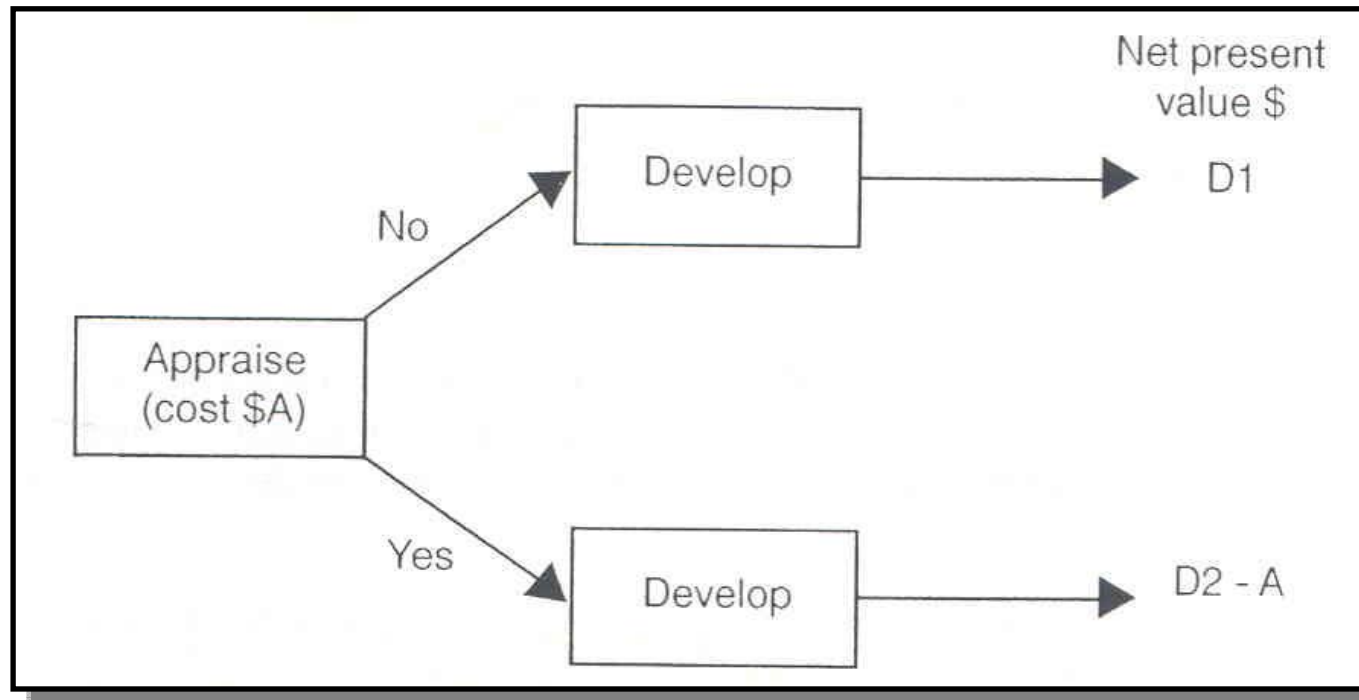

Appraisal has meaning if $D2 - A > D1$

✦ Sources of uncertainty

- Parameters for estimation of STOIP, GIIP, and UR

<i>Input parameter</i>	<i>Controlling factors</i>
gross rock volume	shape of structure dip of flanks position of bounding faults position of internal faults depth of fluid contacts (e.g. OW)
net:gross ratio	depositional environment diagenesis
porosity	depositional environment diagenesis
hydrocarbon saturation	reservoir quality capillary pressures
formation volume factor	fluid type reservoir pressure and temperature
recovery factor (initial conditions only)	physical properties of the fluids (μ , ρ) formation dip angle aquifer volume gas cap volume

- (1) Consider the factors
- (2) Rank the factors
- (3) Consider the uncertainty of factors

✦ Appraisal tools

- Main tool:

Drilling wells and shooting 2D, 3D seismic surveys

- Others

(1) An interference test between two wells

(2) A well drilled in the flank of a field

(3) A well drilled with a long enough horizontal section

(4) A production test on a well

(5) Deepening a well

(6) Coring a well

➤ Reduction of uncertainty

- Impact of appraisal

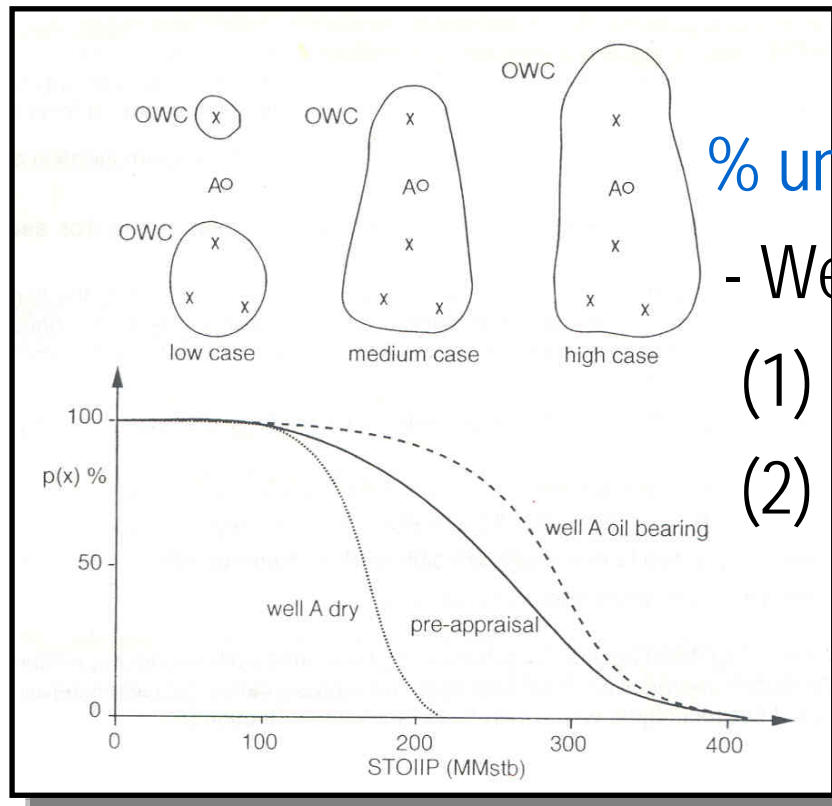

$$\% \text{ uncertainty} = (H-L)/2M * 100\%$$

- Well A is oil-bearing or dry

(1) Expectation curve may shift

(2) Uncertainty range is reduced

✦ Cost-benefit calculation

- NPV calculation

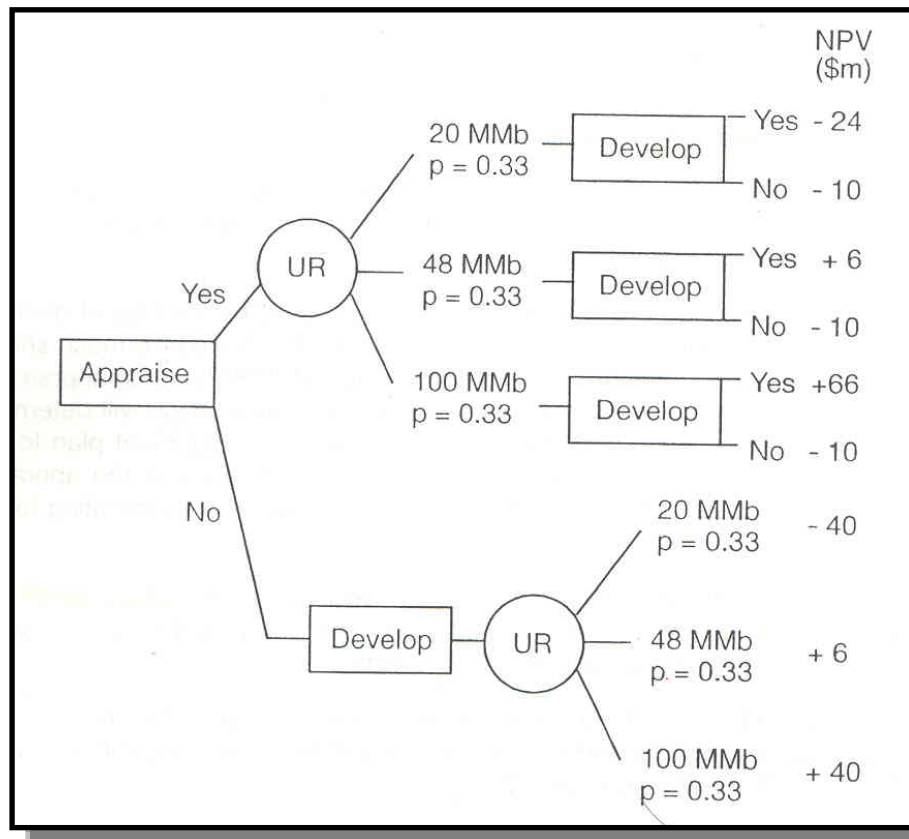

- With appraisal
 $\$(0+6+66)/3=+\24

- Without appraisal
 $\$(-40+6+40)/3=+\2



Reservoir Dynamic Behavior



✦ The driving force for production

- Reduction of pressure \longrightarrow Increase of volume

- Compressibility, $c = -\frac{1}{V} \frac{dV}{dP}$

- Underground withdrawal of fluid

$$dV = [c_o V_o + c_g V_g + c_w V_w] \cdot dP$$

✦ The driving force for production

- Driving force
 - (1) primary recovery
 - (2) secondary recovery

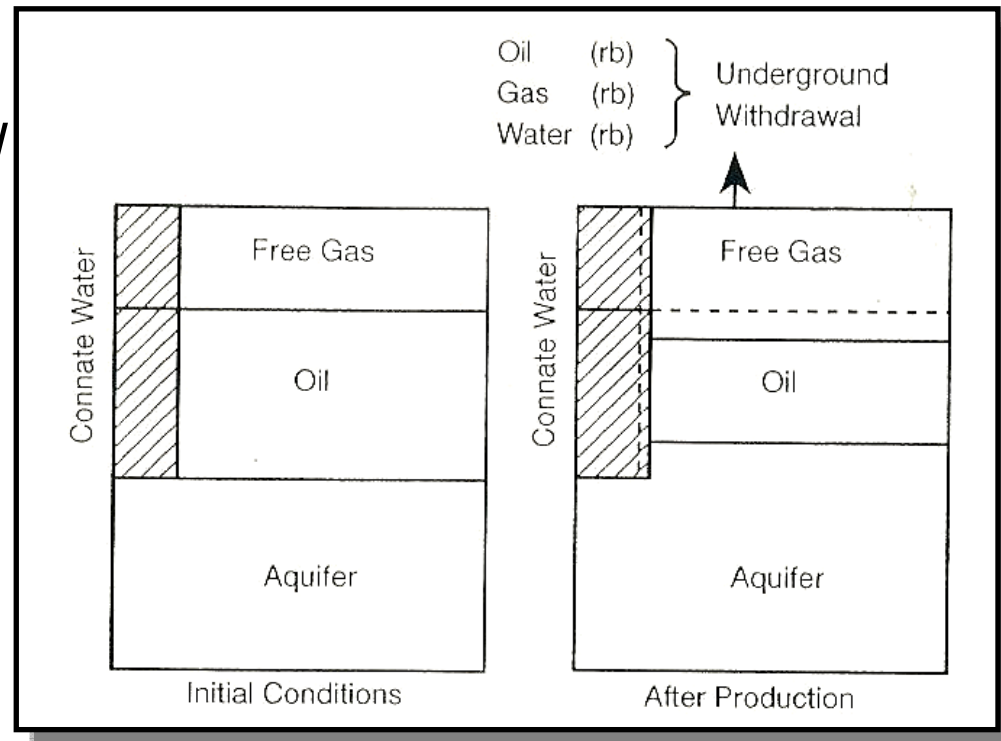

✦ The driving force for production

- Material balance equation

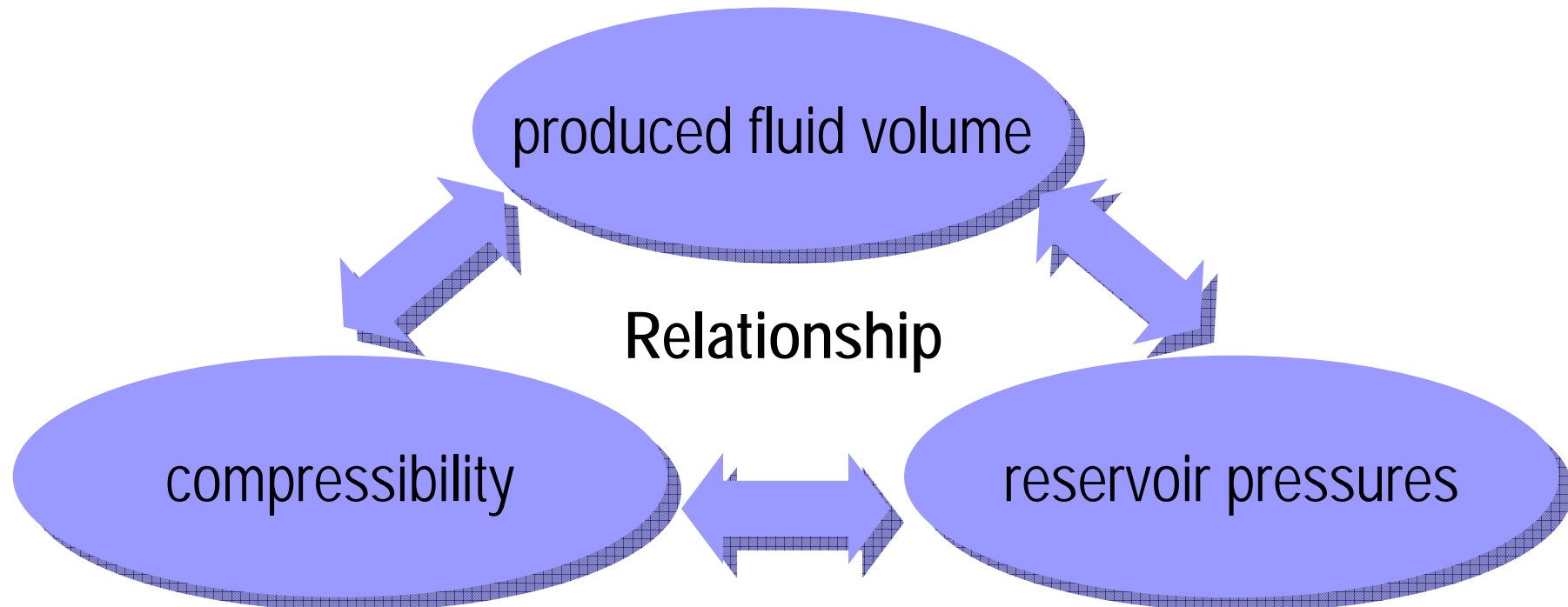

✦ Reservoir Driving Mechanisms

Drive mechanism	Initial condition
Solution gas drive	Undersaturated oil (no gas cap)
Gas cap drive	Saturated oil with a gas cap
Water drive	Saturated or undersaturated oil
With a large underlying aquifer	

✦ Solution gas drive

- No initial gas cap or active aquifer
- Oil is produced: expansion of oil, connate water and any compaction drive
- Pressure drops rapidly as production takes place, until p_b
- Material balance equation

$$N_p B_o = N \cdot B_{oi} \cdot c_e \cdot \Delta P$$

✦ Solution gas drive

- Three phases during oil production
 - (1) build up period
 - (2) plateau period
 - (3) decline period
- Recovery factor is in the range 5- 30%

$$water\ cut = \frac{water\ production(stb)}{oil\ plus\ water\ production(stb)} \times 100(\%)$$

➤ Solution gas drive

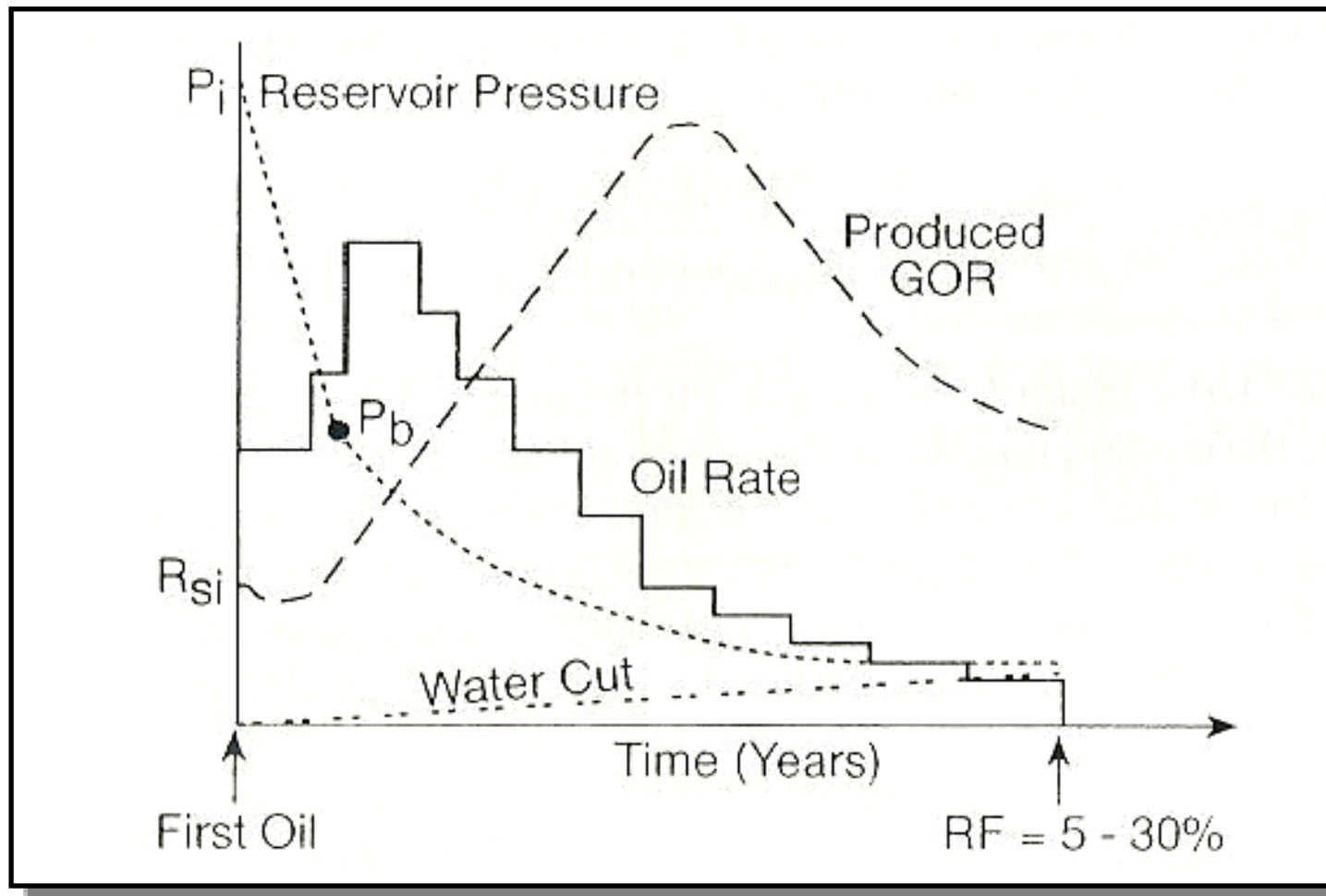

✦ Gas cap drive

- Initial existence of gas cap
- Gas expansion gives drive energy for production
- Well is installed as far away from the gas cap as possible
- Compared to solution gas drive, gas cap drive shows a much slower decline
- Recovery factor is in the range of 20-60%

✦ Gas cap drive

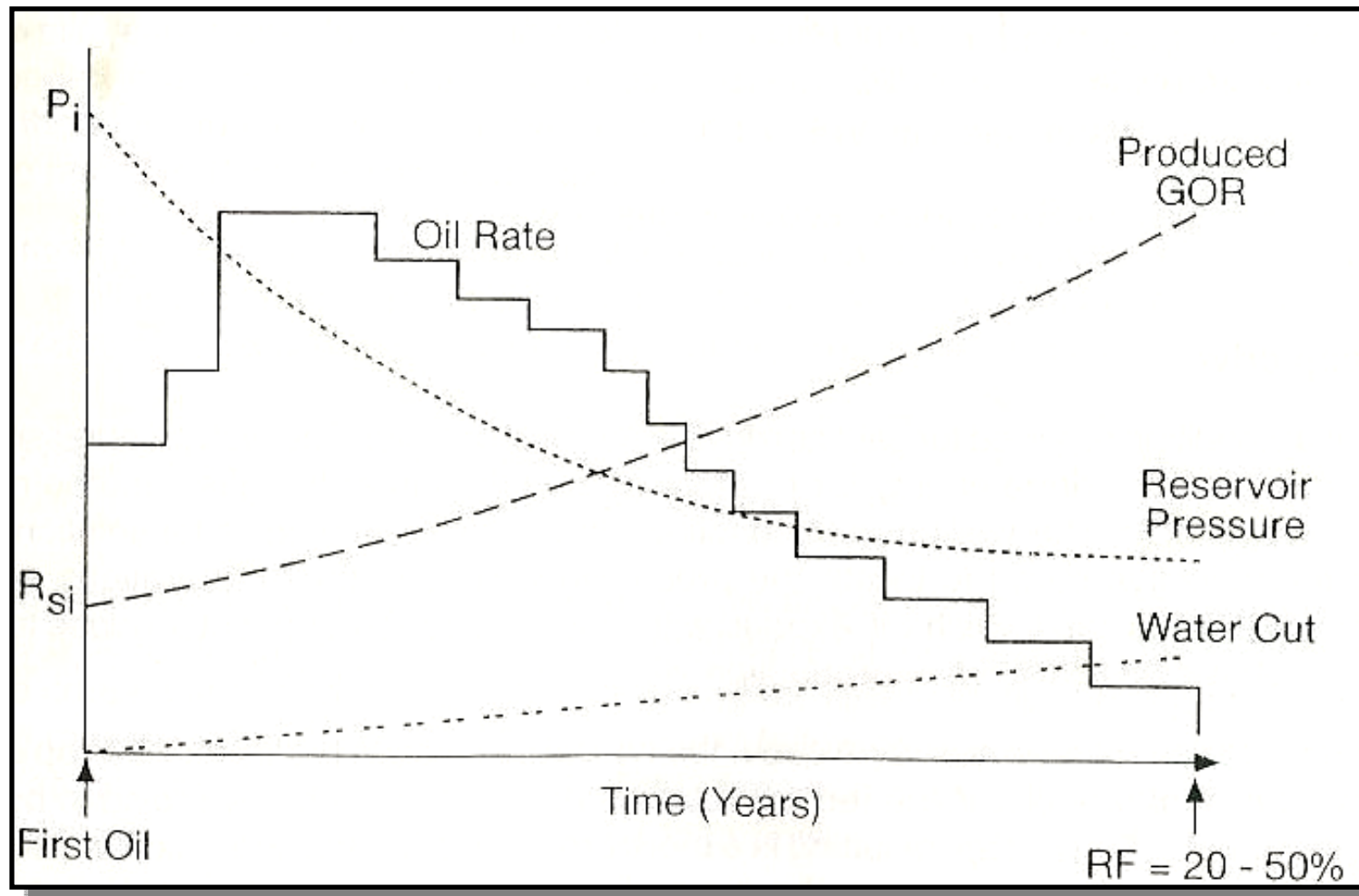

✦ Water drive

- Occurs when the underlying aquifer is large
- Water must be able to flow into the oil column
- Difficult to plan the reservoir development by a uncertainty of aquifer behavior
- Using the response of reservoir pressure, fluid contact movement and MBE, we can see the reaction of aquifer
- Recovery factor is in the range 30-70%

➤ Water drive

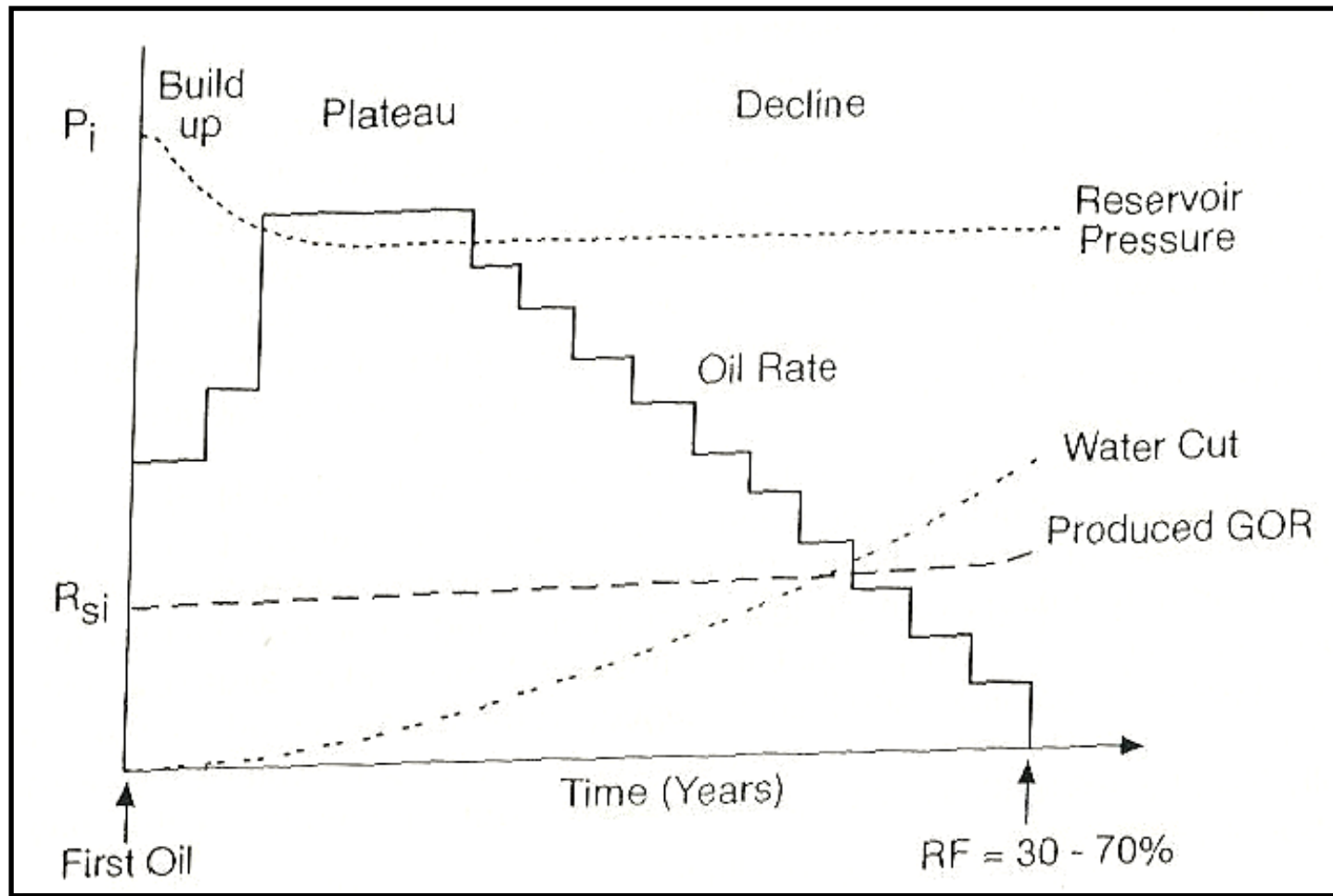

✦ Gas reservoirs

- Produced by expansion of the gas contained in the reservoir
- Must ensure a long sustainable plateau to attain a good sales price for the gas
- Recovery factor depends on how low the abandonment pressure can be reduced
- Recovery factor is in the range 50-80%

✦ Differences between oil and gas field

- The economics of transportation gas
- The market for gas
- Product specifications
- The efficiency of turning gas into energy

✦ Gas sales profiles; influence of contracts

- A guaranteed minimum quantity of gas for as long a duration as possible
- Peak in production when required

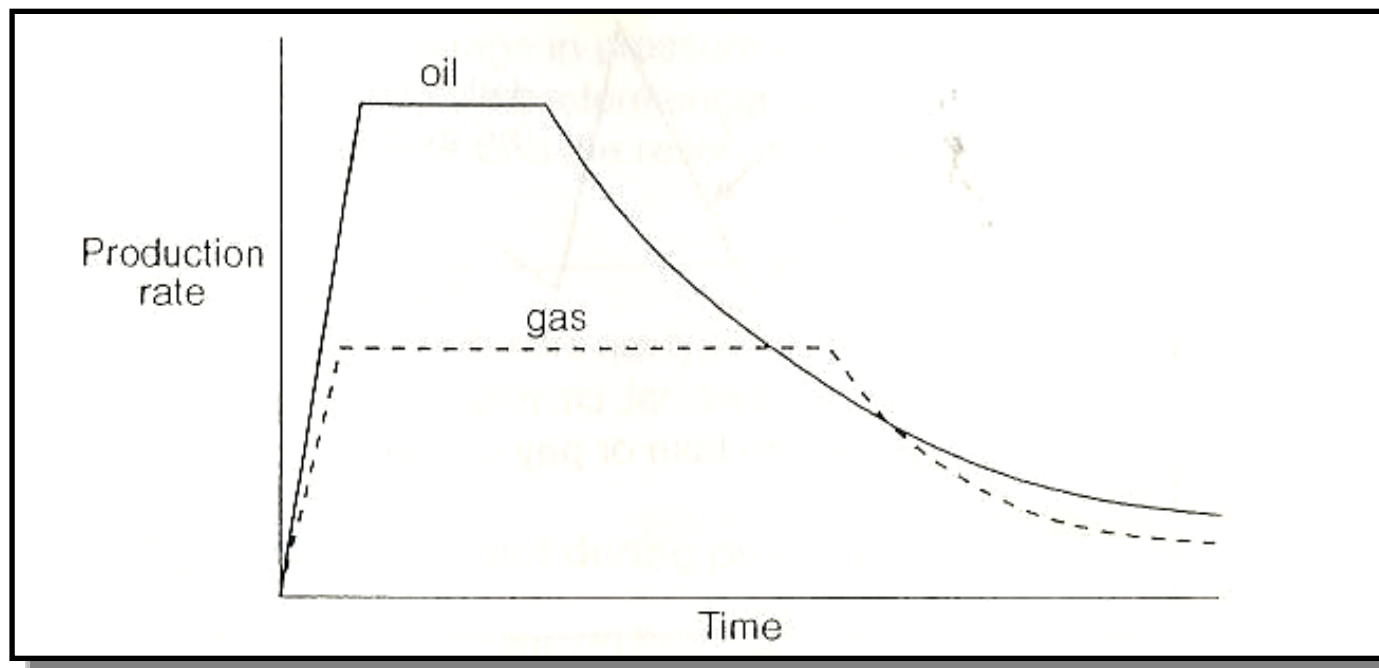

✦ Gas sales profiles; influence of contracts

- Daily contact quantity (DCQ)
- Swing factor
- Take or pay agreement
- Penalty clause

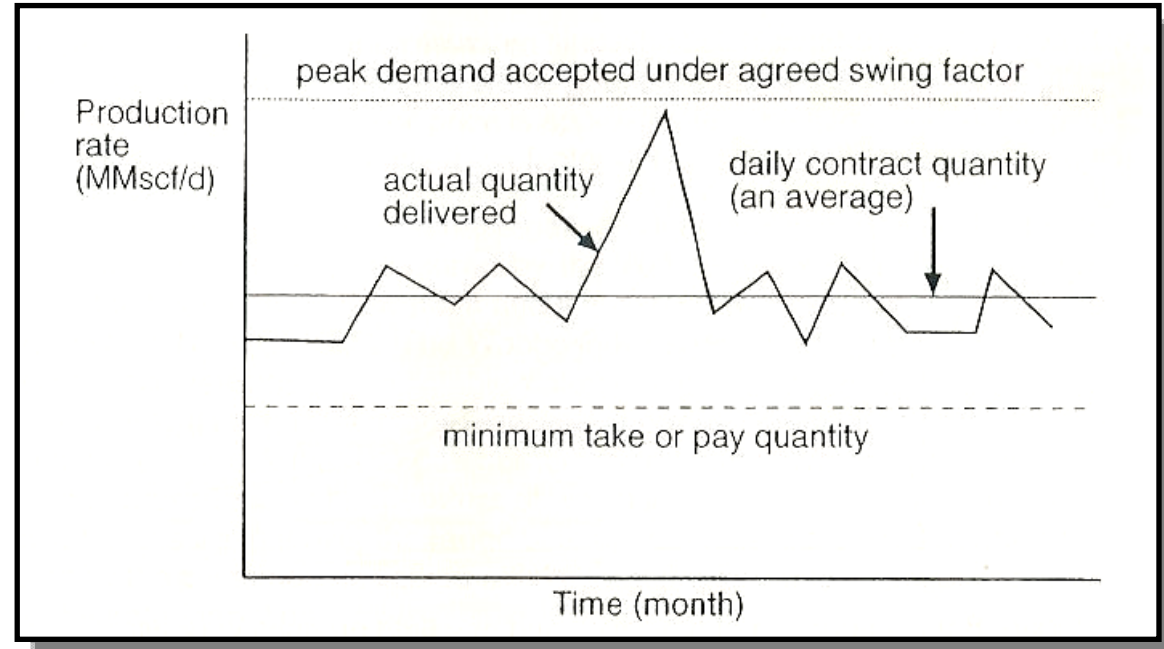

✦ Subsurface development

- One of major difference in fluid flow for gas field compared to oil field is mobility difference

$$mobility = \frac{k}{\mu}$$

- In a gas reservoir underlain by an aquifer, the gas is highly mobile to compared to water and flow readily to the producers
- Producer are typically positioned at the crest of the reservoir

✦ Subsurface development

- As the gas is produced, the pressure in the reservoir drops, and the aquifer responds to this by expansion and moving into the gas column.
- Pressure response to production
 - (1) primary drive mechanism is the expansion of the gas
 - (2) RF is linked to the drop in reservoir pressure in an almost linear manner

➤ Subsurface development

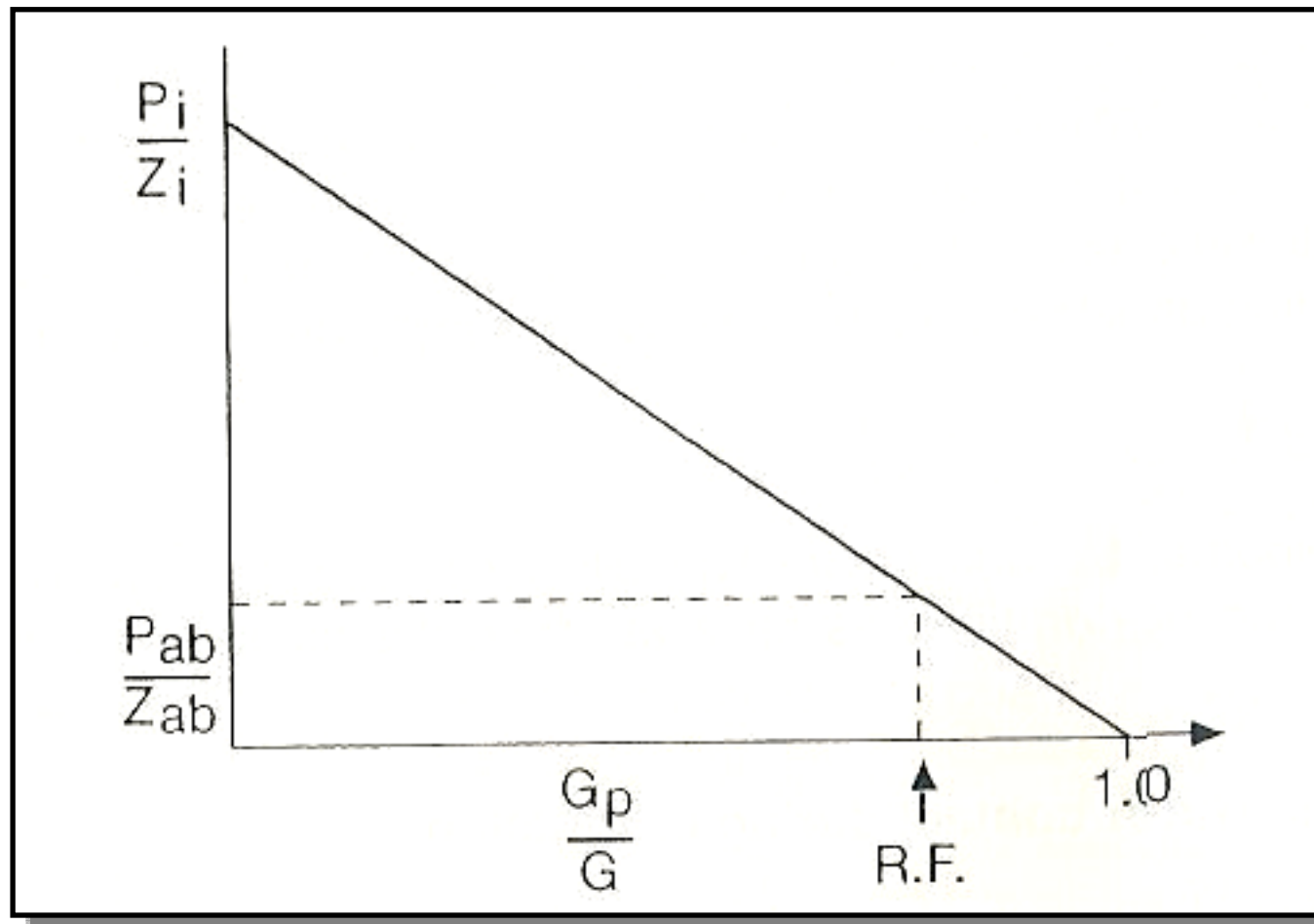

✦ Surface development for gas fields

- The amounts of processing required in the field depends on the composition of the gas and the temperature and pressure to which the gas will be exposed during transportation.
- For dry gas, the produced fluid are often exported with very little processing
- Wet gas may be dried of the heavier hydrocarbons by dropping the temperature and pressure through a Joule-Thompson expansion valve.

✦ Surface development for gas fields

- Gas containing water vapor may be dried by passing the gas through a molecular sieve
- Gas reservoirs may also be used for storage of gas

✦ Fluid displacement in the reservoir

- Oil is left behind due to *by-passing*
- RF = Macroscopic sweep efficiency X

Microscopic displacement efficiency

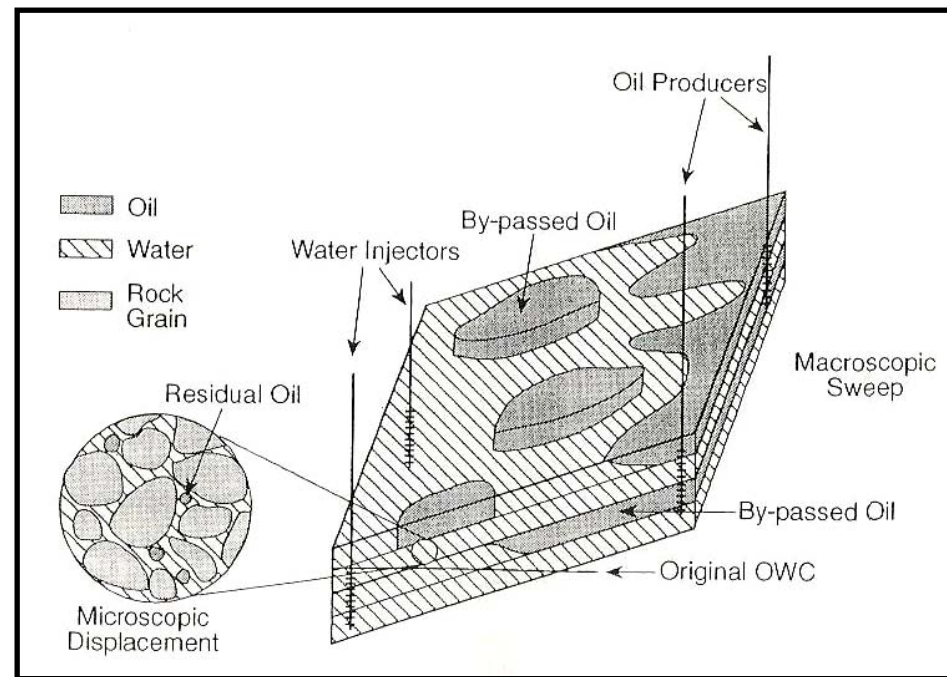

✦ Fluid displacement in the reservoir

- Darcy's law
- Oil reservoir: 100md (good), 10md (poor)
- Gas reservoir: 1md (reasonable: lower viscosity than oil)
- Relative permeability

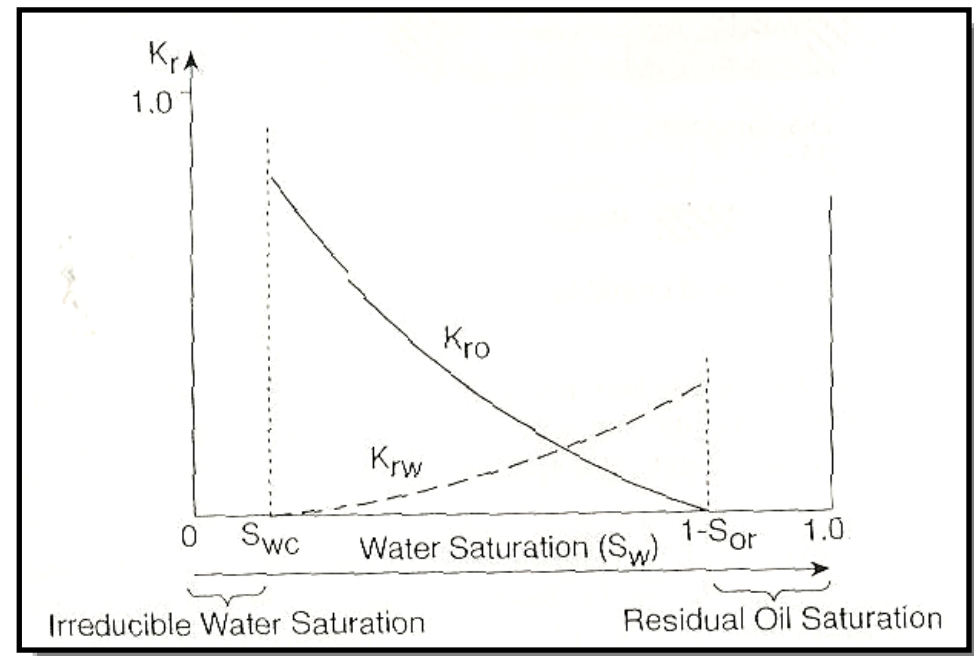

✦ Fluid displacement in the reservoir

- Mobility ratio (M)

$$= \frac{\frac{k_{rw}}{\mu_w}}{\frac{k_{ro}}{\mu_o}}$$

- If $M > 1$, viscous fingering occurs

✦ Fluid displacement in the reservoir

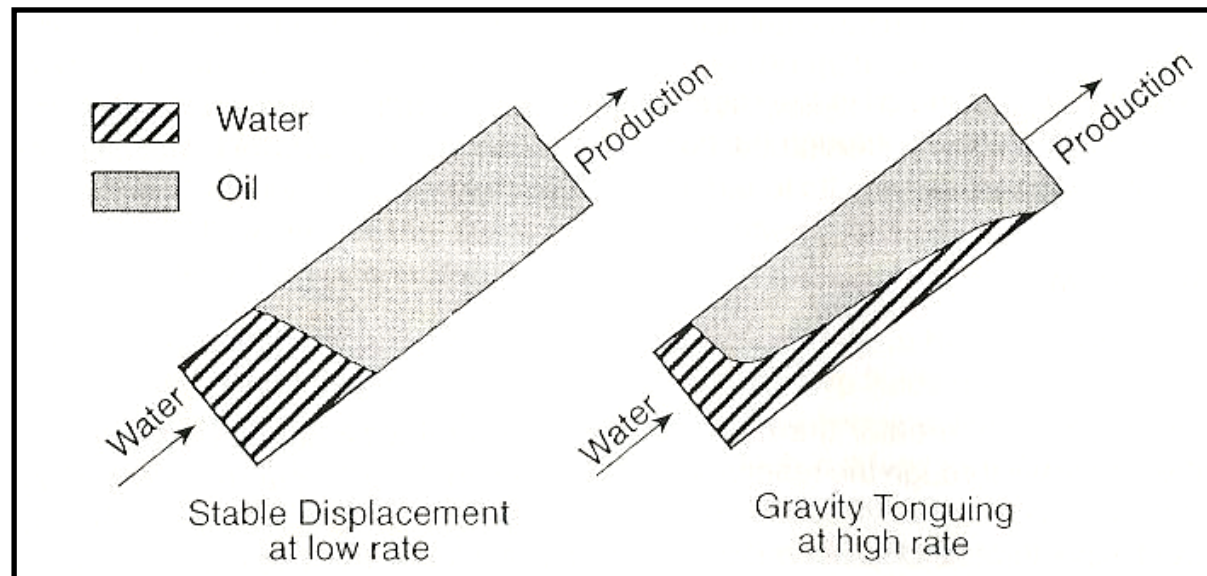
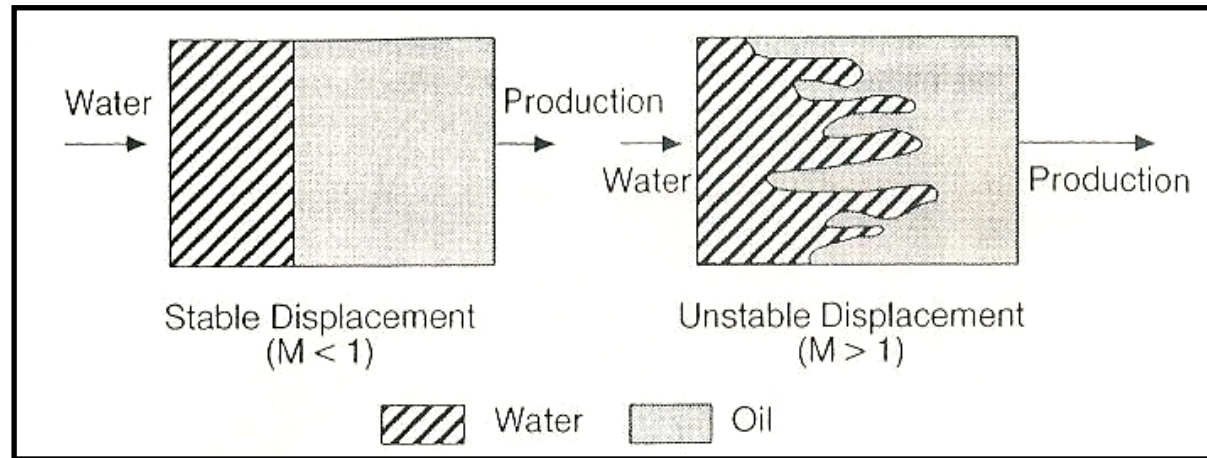

✦ Reservoir simulation

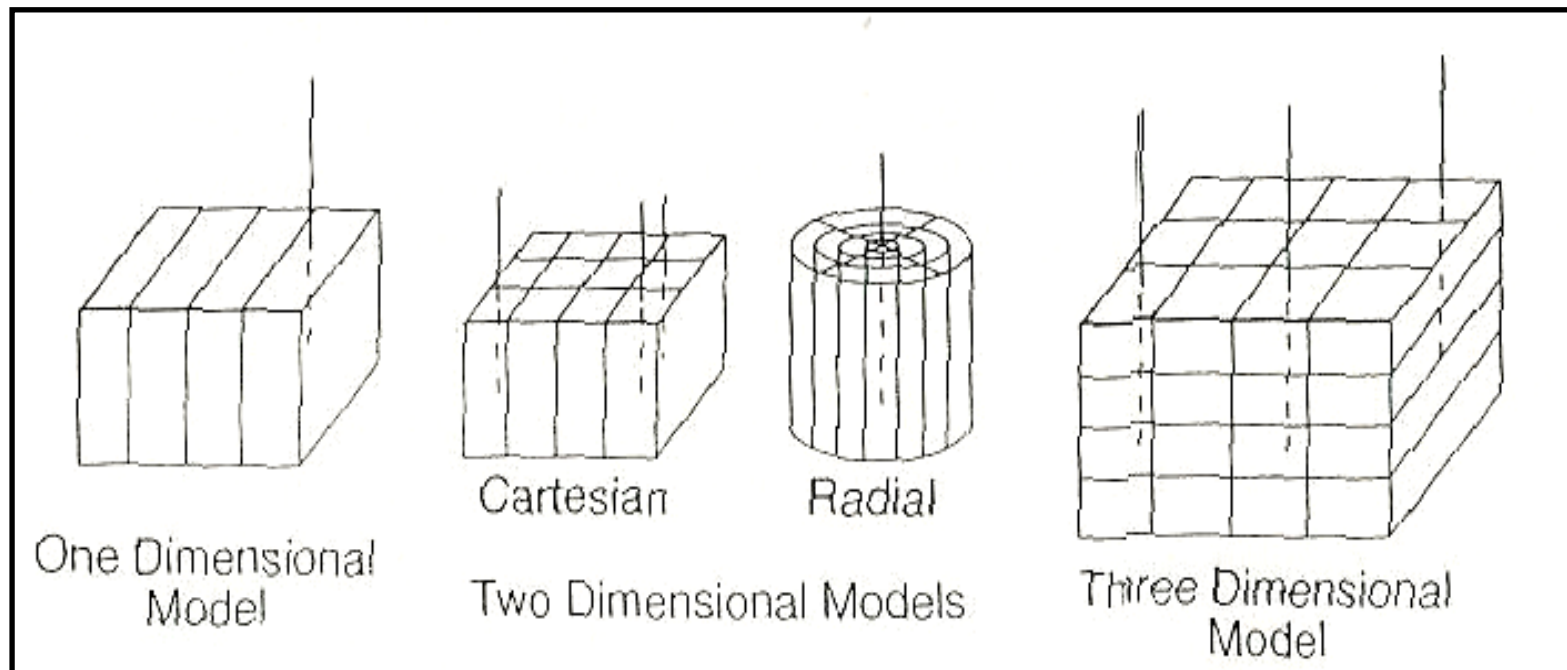

✦ Estimating the recovery factor

- Ultimate recovery = HCIIP x RF
- Reserves = UR – cumulative production
- Main technique for estimating the RF
 - (1) Field analogues
 - (2) Analytical models (displacement calculations, MBE)
 - (3) Reservoir simulation

✦ Estimating the production profiles

- Production profile is the only source of revenue for most projects, and making a production forecast is of key importance for economic analysis of a proposal

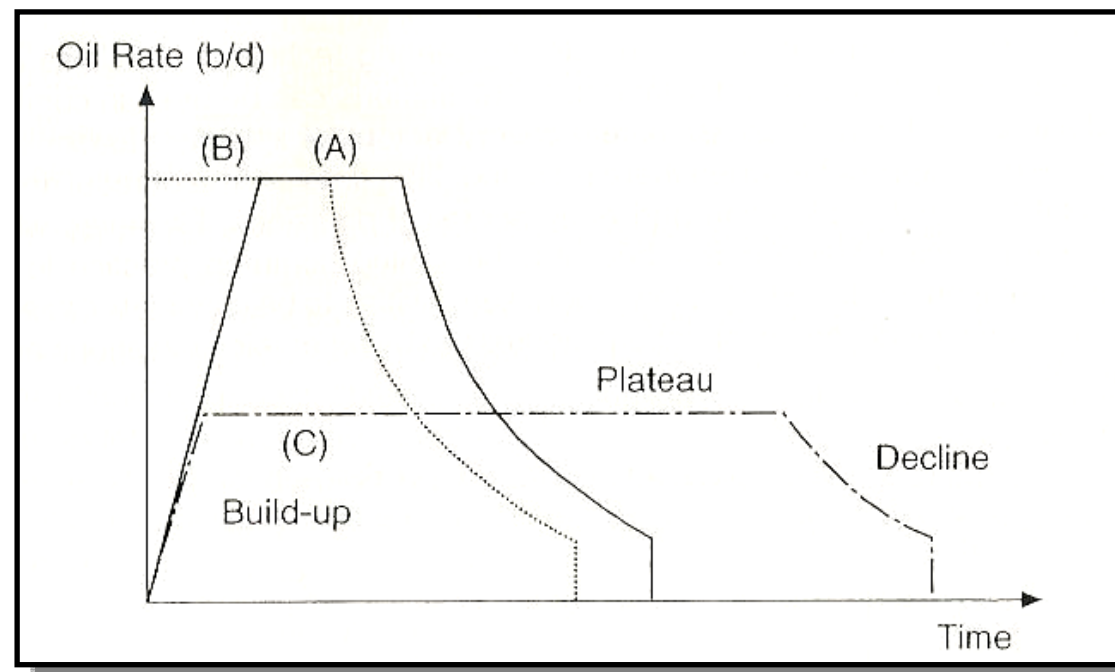

✦ Enhanced oil recovery

- Thermal technique: reduce the viscosity of heavy crude
- Chemical technique: polymer flooding / surfactant flooding
- Miscible processes

Enhanced oil recovery

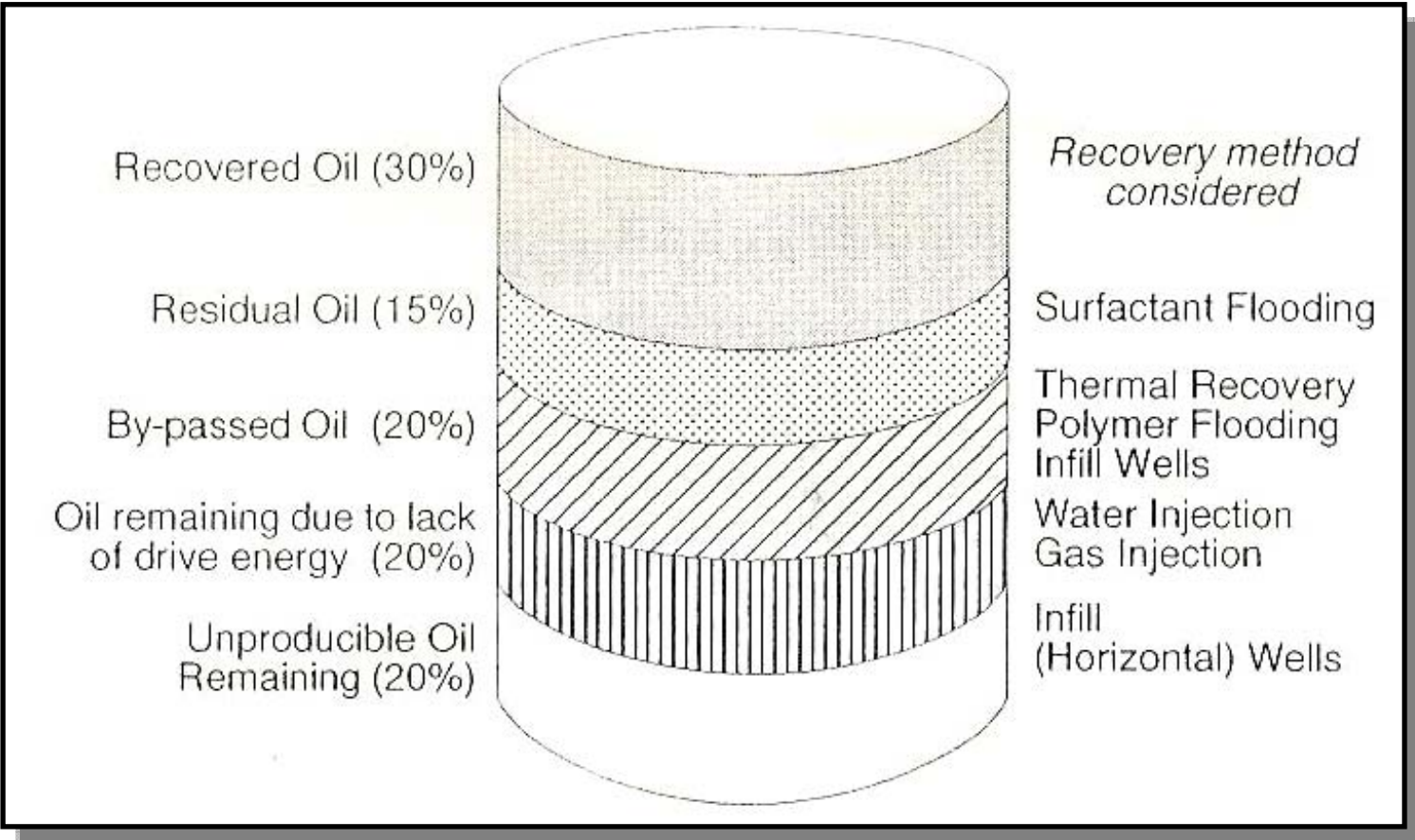



Well Dynamic Behavior



✦ The number of development wells

- The drilling expenditure: 20~40% of the total capex
- Estimate the number of wells by considering
 - (1) The type of development
(e.g. gas cap drive, water injection, natural depletion)
 - (2) The production / injection potential of individual wells

■ Number of production wells = $\frac{\text{Plateau production rate [stb/d]}}{\text{Assumed well initial [stb/d]}}$

✦ Fluid flow near the wellbore

- Pressure drawdown

$$D P_{DD} = \bar{P} - P_{wf}$$

- Productivity index PI

$$PI = \frac{Q}{D P_{DD}}$$

- For semi – steady state,

$$Q = \frac{D P_{DD} gkh}{141.2 n B_o \left\{ \ln \frac{r_e}{r_w} - \frac{3}{4} + S \right\}}$$

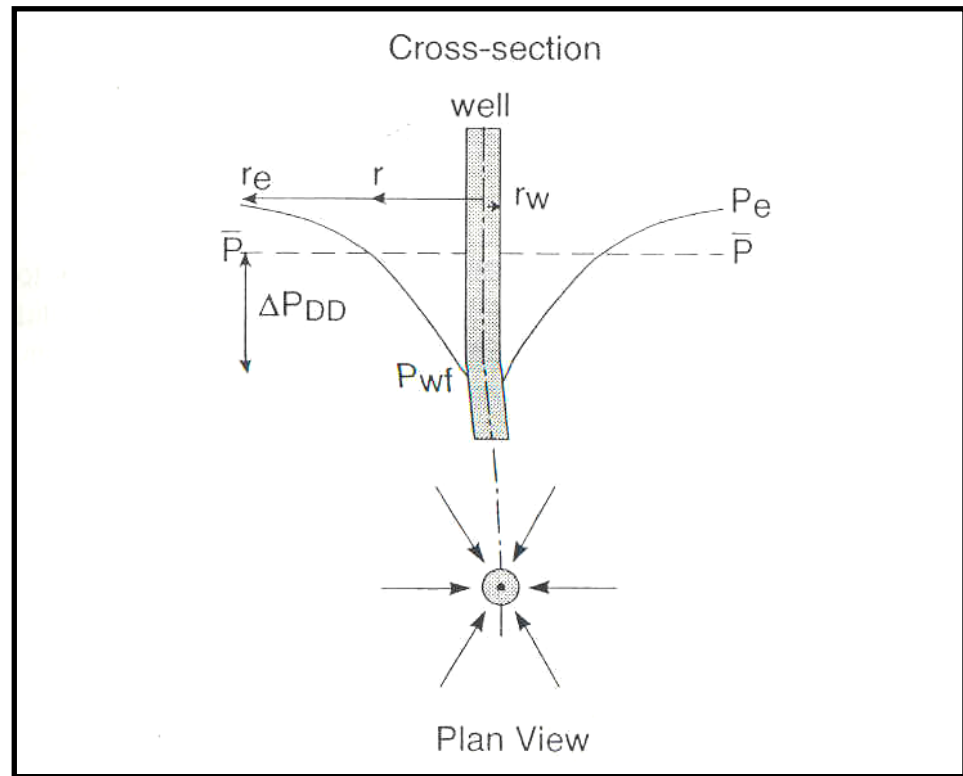

✦ Fluid flow near the wellbore

- Damage skin, geometric skin, turbulent skin

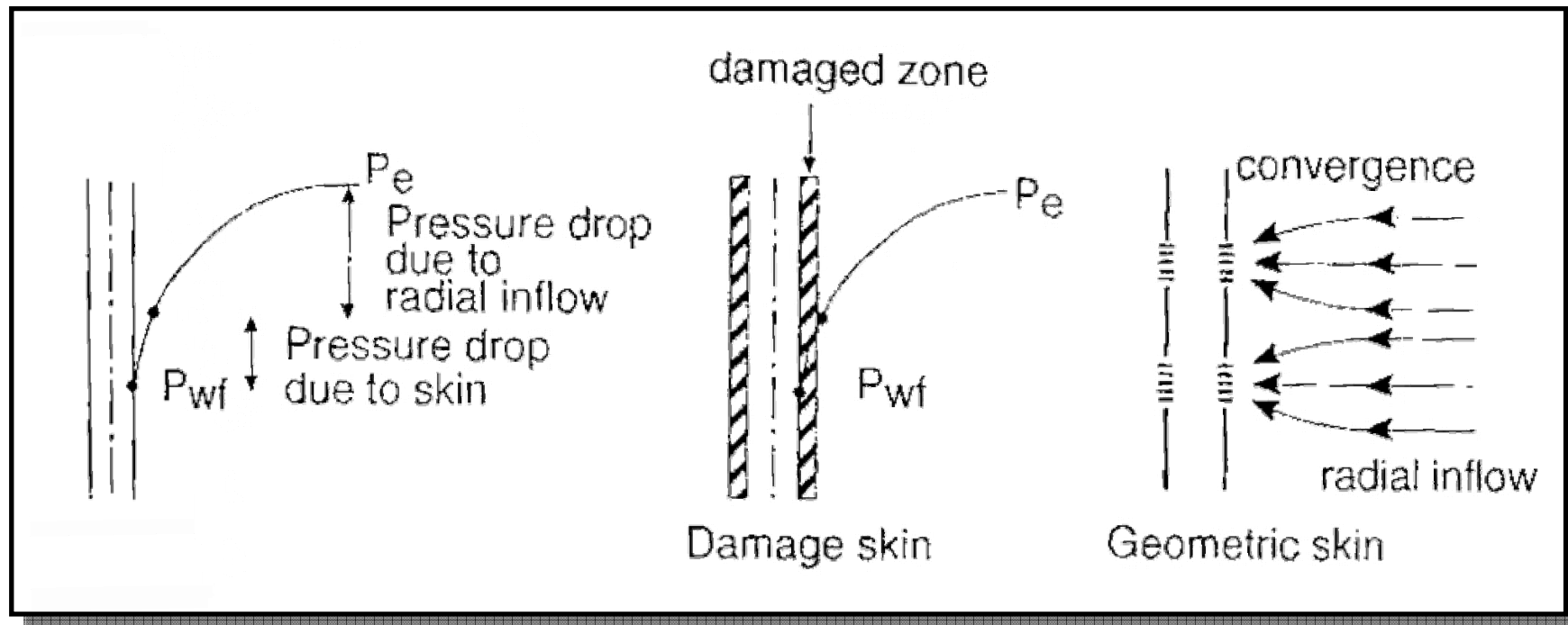

✦ Fluid flow near the wellbore

- Coning: occurs in the vertical plane,
when OWC lies directly below the producing well
- Cusping: occurs in the horizontal plane,
when OWC doesn't lie directly beneath the producing well

✦ Fluid flow near the wellbore

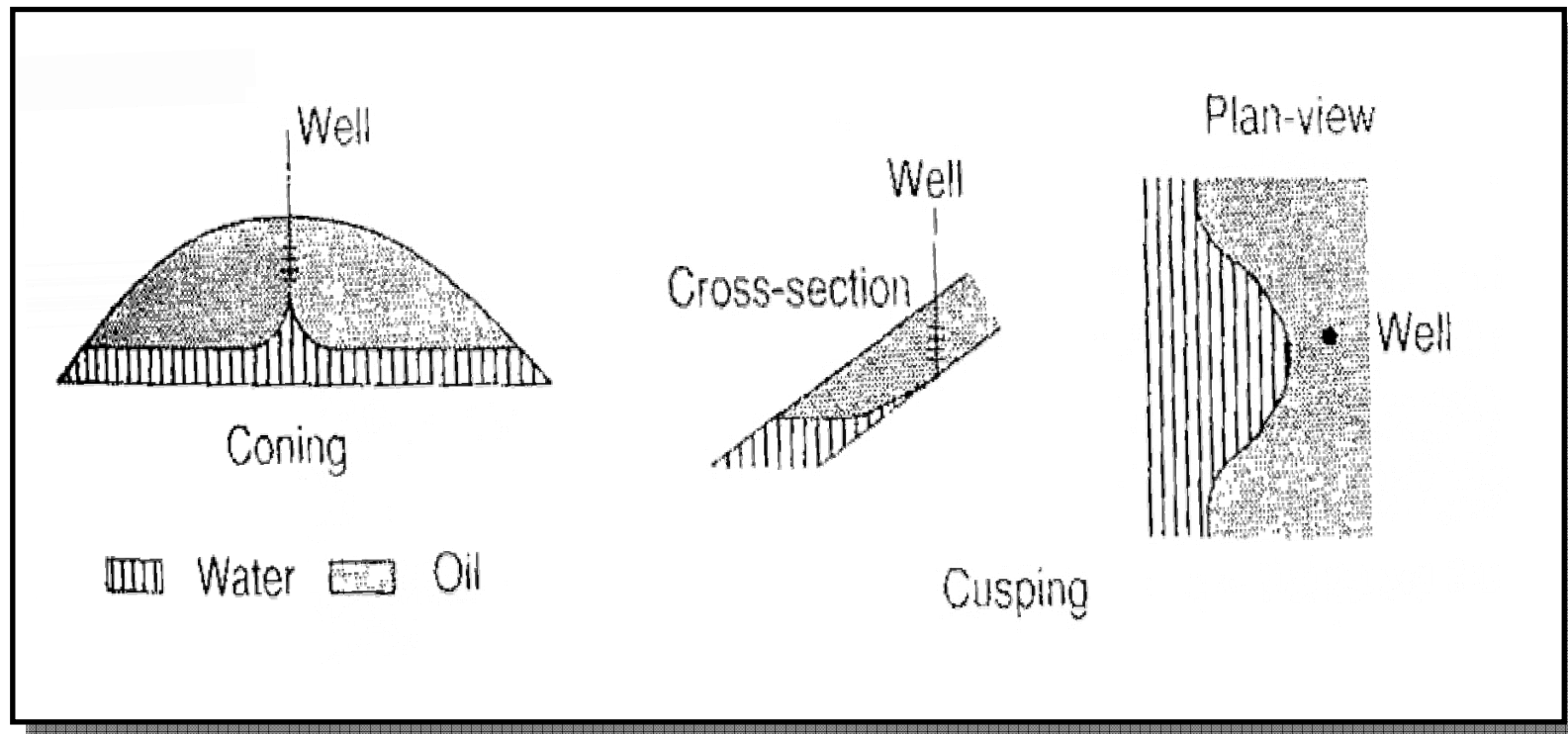

✦ Horizontal wells

- Advantage
 - (1) Increased exposure to the reservoir giving higher productivity (PI)
 - (2) Ability to connect laterally discontinuous features (e.g. fractures, fault blocks)
 - (3) Changing the geometry of drainage (e.g. being parallel to fluid contacts)

✦ Horizontal wells

- Productivity improvement factor (PIF)

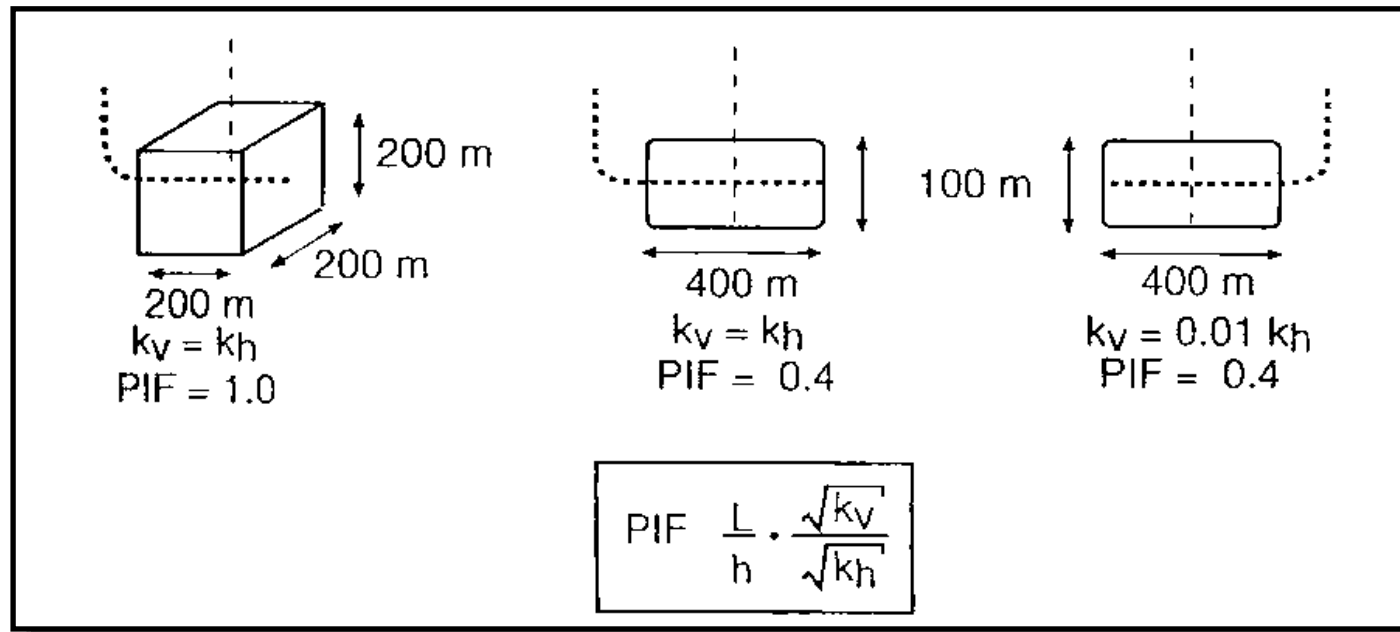

✦ Horizontal wells

- Effective horizontal well length

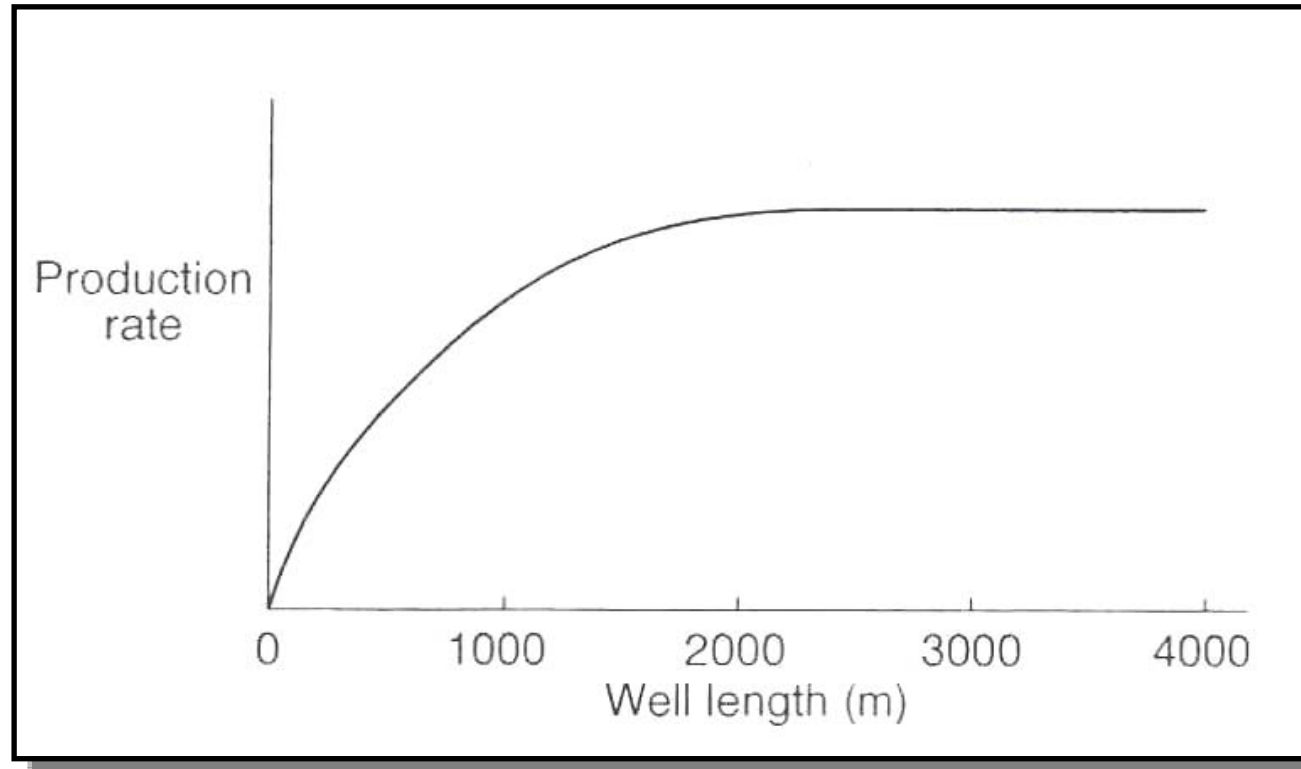

✦ Horizontal wells

- Ability to connect laterally discontinuous features

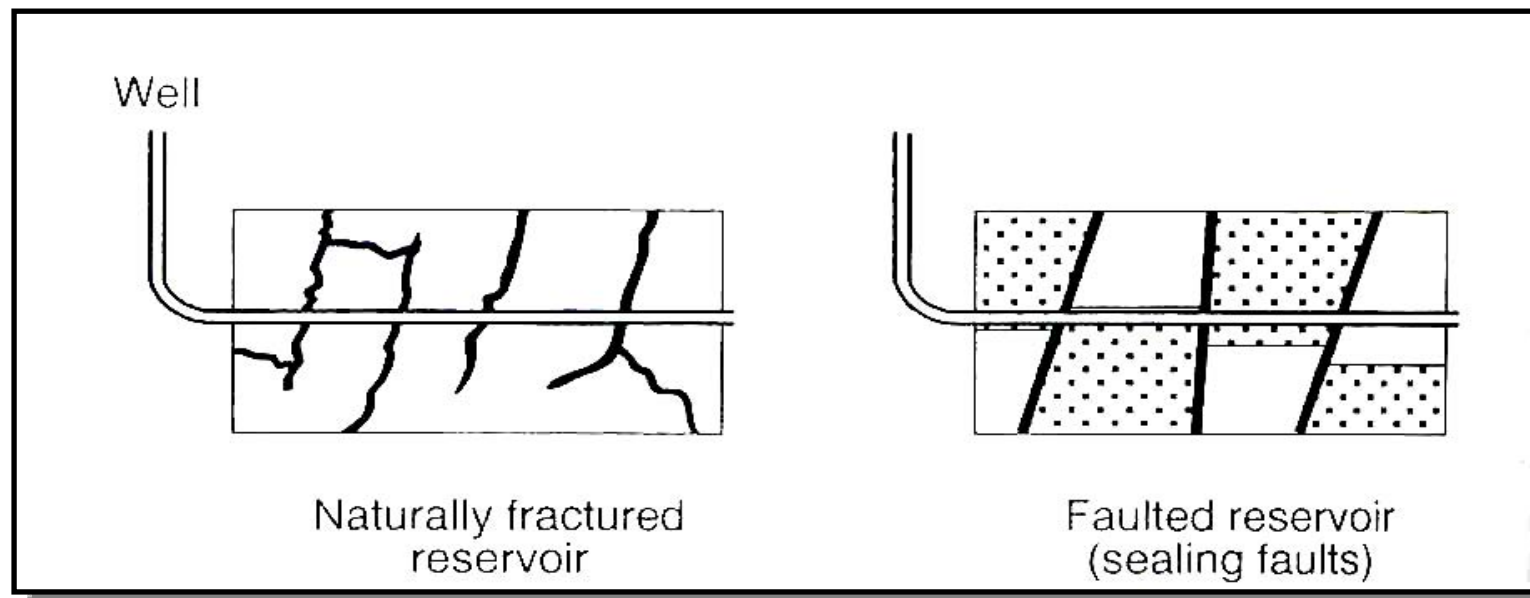

✦ Horizontal wells

Changing the geometry of drainage

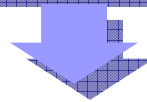

Minimising the effect of coning or cusping

- Particularly strong advantage in thin oil columns (less than 40m thick)

✦ Horizontal wells

- Cresting: the distortion of the fluid interface near the horizontal well

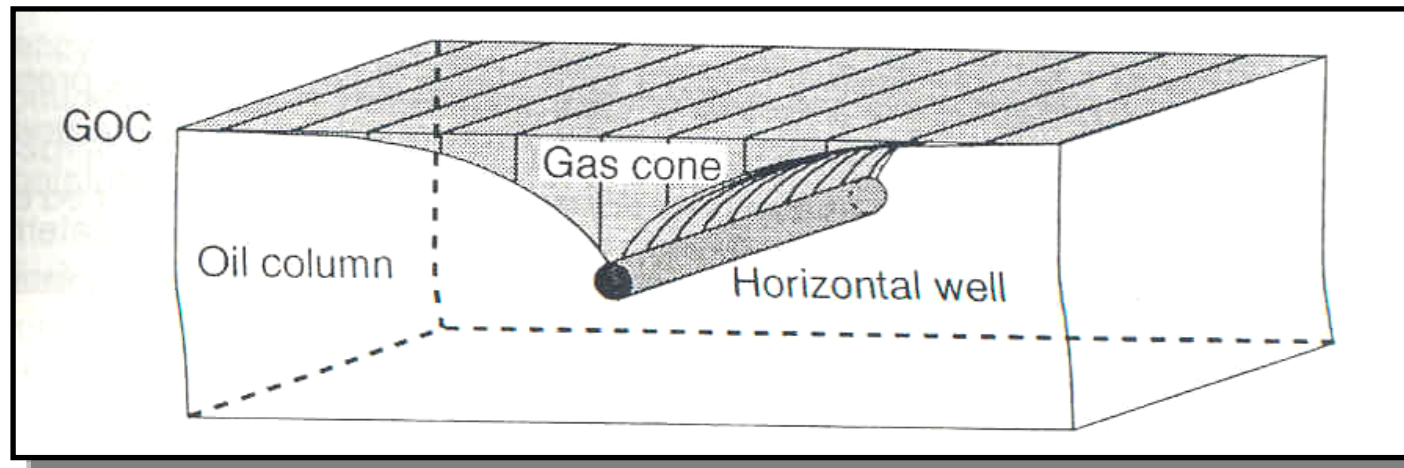

✦ Production testing & p_{wf} testing

- Production testing
 - (1) Per month
 - (2) Information: liquid flow rate, water cut, gas production rate

- Bottom hole pressure testing
 - (1) Determine the reservoir properties (e.g. permeability, skin)
 - (2) SBHP (static bottom hole pressure survey)
 - (3) FBHP (flowing bottom hole pressure survey)

Production testing & P_{wf} testing

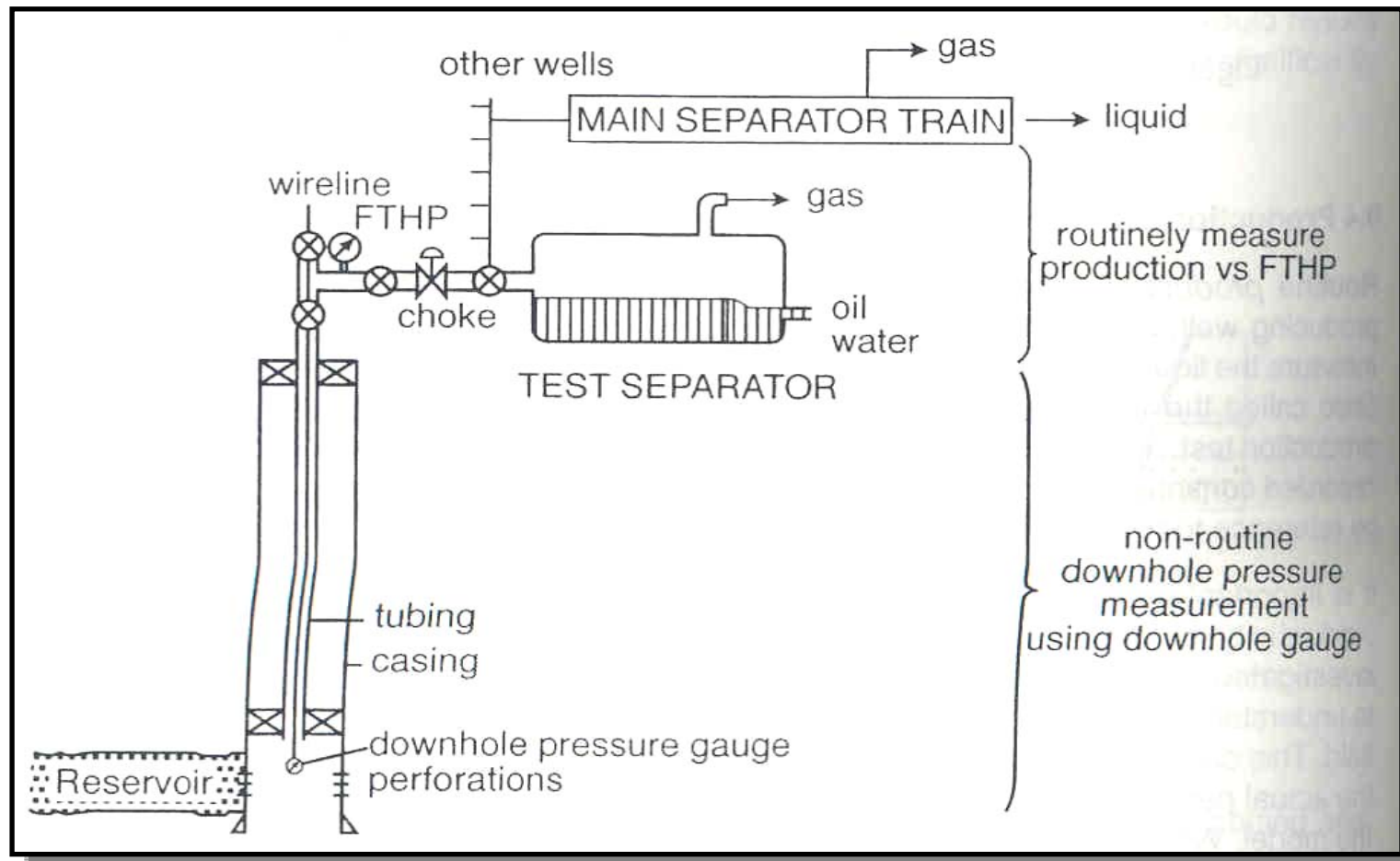

✦ Production testing & P_{wf} testing

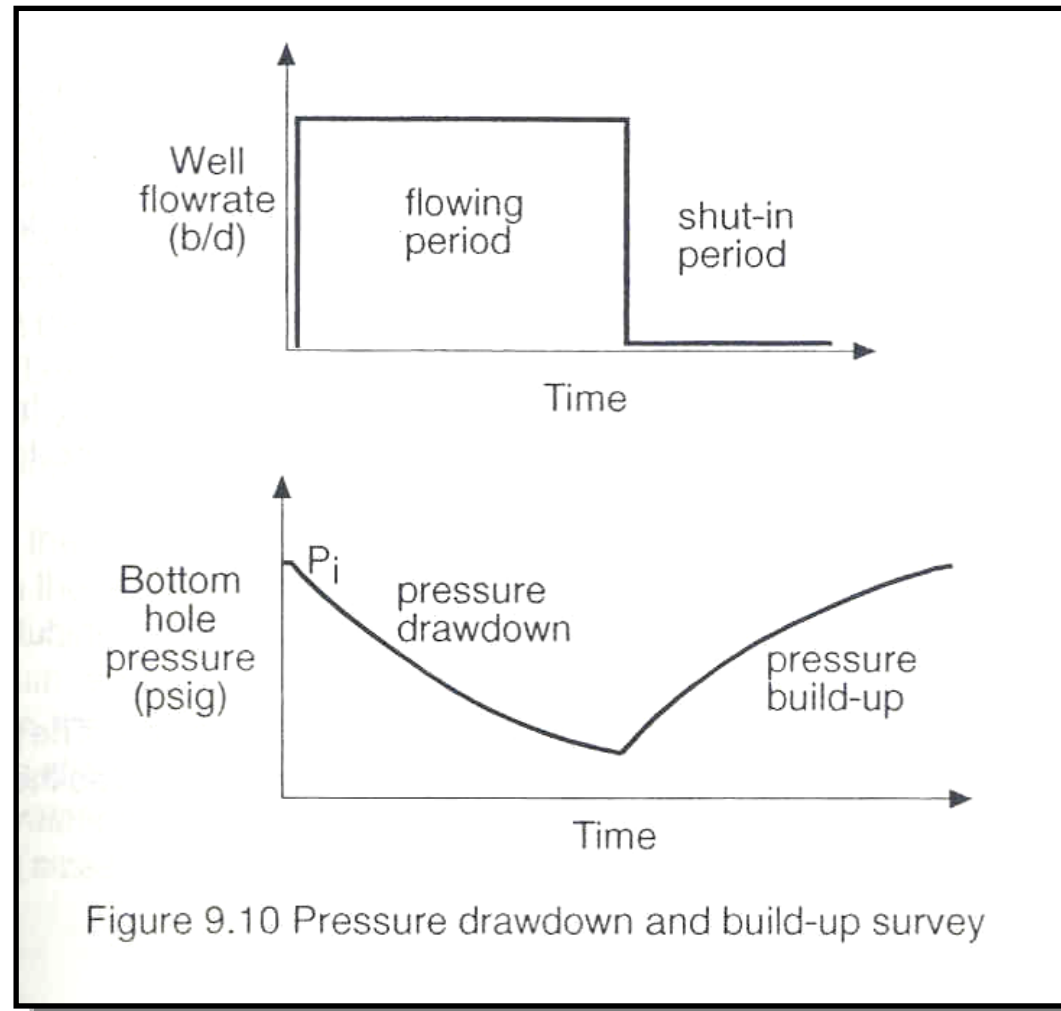

Production testing & P_{wf} testing

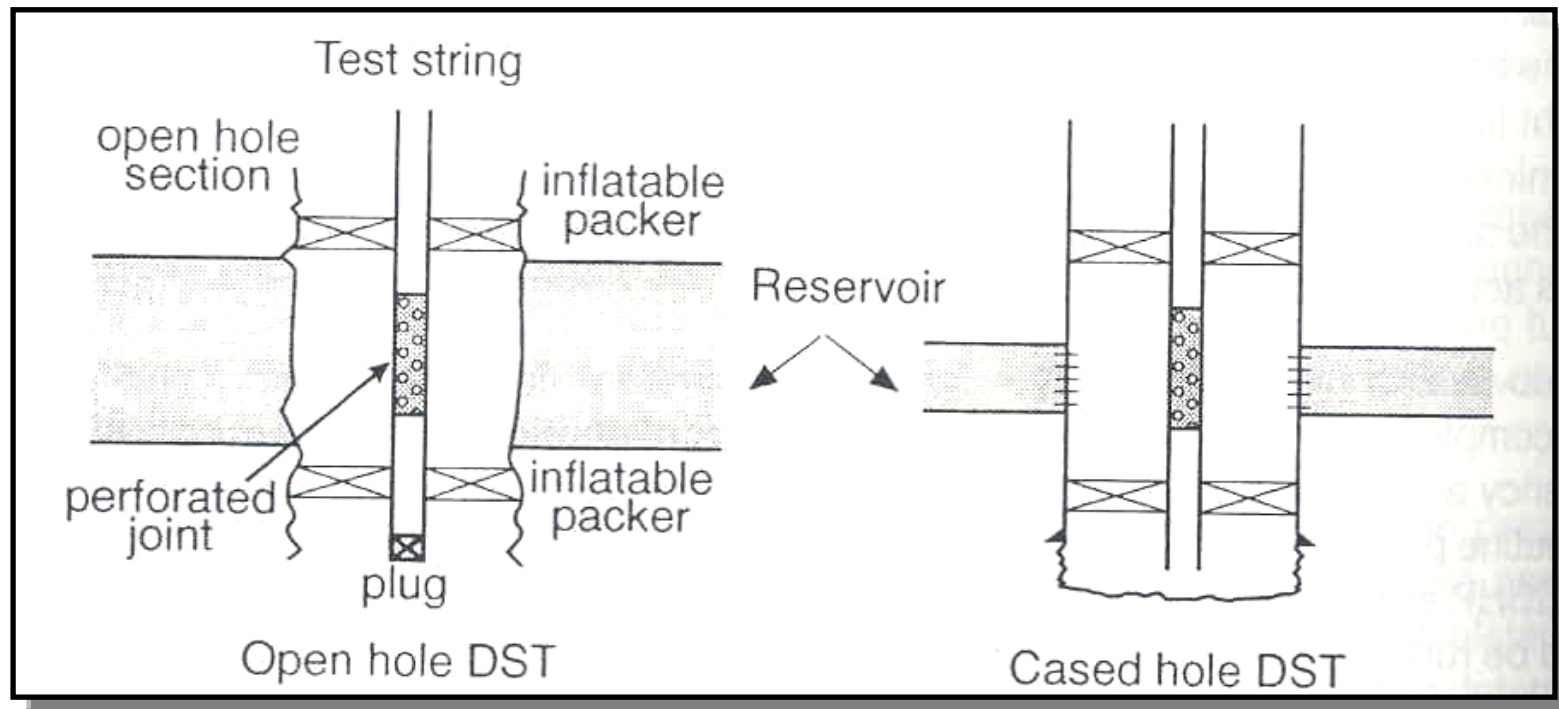

✦ Tubing performance

- Determine the size

(1) Measure

p_{wf} (bottom hole pressure), p_{th} (tubing head pressure),
 p_{sep} (separator pressure)

(2) Plot IPR curve & TPC

Tubing performance

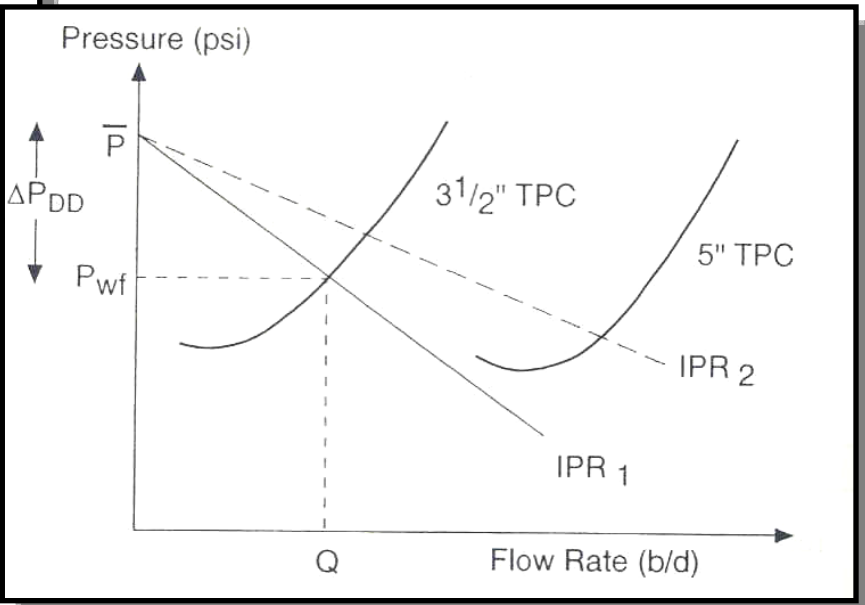
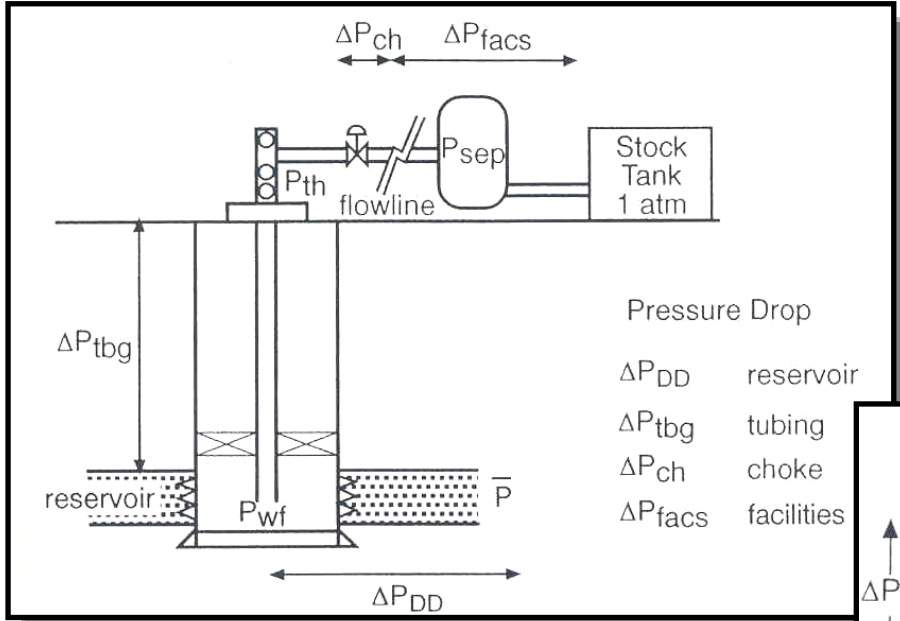

Well completion

- To provide a safe conduit for fluid flow from the reservoir to the flowline

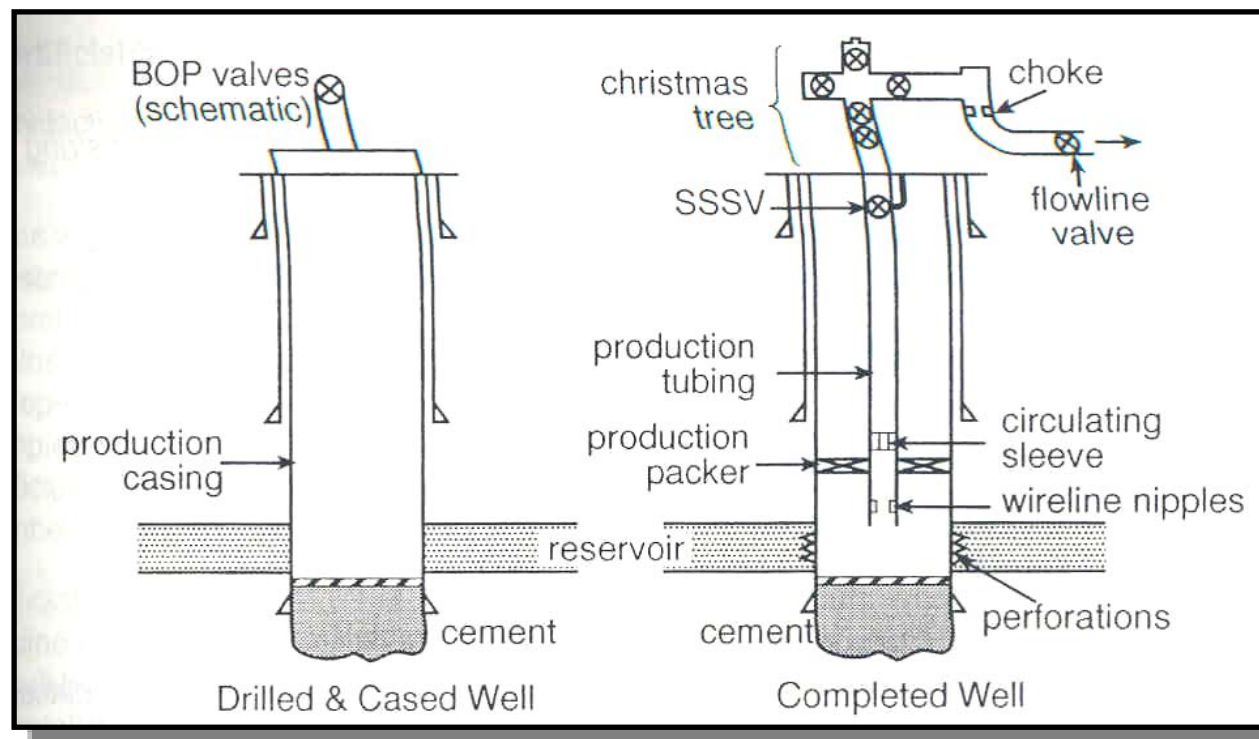

✦ Well completion

- Many variations exist
(gravel pack completion, dual string completion)

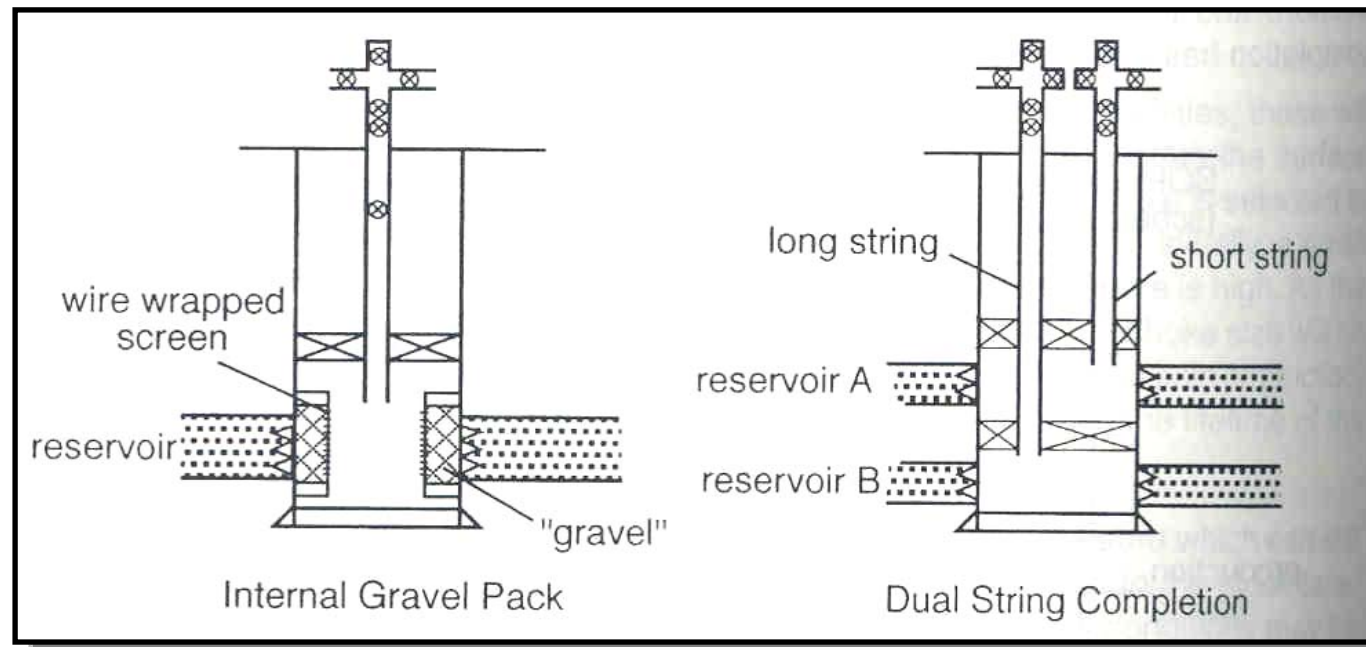

✦ Well completion

- Horizontal wells

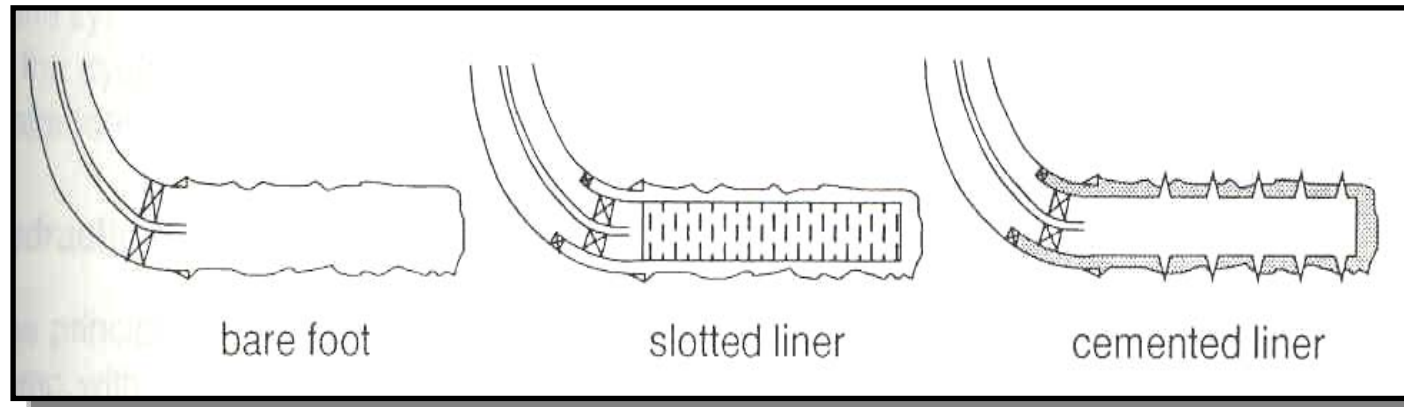

✦ Artificial lift

- Add energy to the produced fluids, either to accelerate or to enable production
 - Performed in the well
 - Common in the North Sea
 - Later in a field's life
- 

✦ Artificial lift

- Types of artificial lift

(1) Beam Pump (BP)

(2) Progressive Cavity Pump (PC)

(3) Electric Submersible Pump (ESP)

(4) Hydraulic Reciprocating Pump (HP)

(5) Hydraulic Jet Pump (JET)

: mixing a fluids of high kinetic energy with a oil

(6) Continuous Flow Gas Lift (GL)

(7) Intermittent Gas Lift (IGL)

Artificial lift

- Determine an effective type of artificial lift by capabilities, hydraulic efficiencies, and constraints

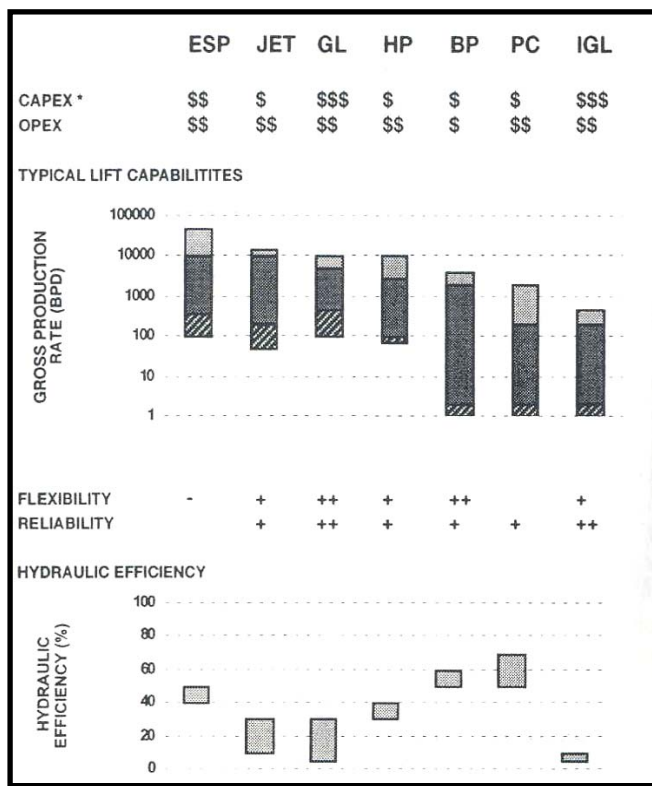

CONSTRAINTS	ESP	JET	GL	HP	BP	PC	IGL
DRAWDOWN		-	-			+	+
VISCOUS OIL		+	-			+	++
SOLIDS		-	+			-	++
GAS		-	+			++	-
HIGH TEMP		-	+			+	+
DEPTH		-	+			+	-
DEVIATED			++			+	-
DOGLEGGED		+	+			++	+
SURVEYING		-				+	-
TESTING		+	-			-	+
OFFSHORE		+	++			++	-

* ASSUMING THAT NO INFRASTRUCTURE EXISTS



Surface Facilities



✦ Oil and Gas Processing

✦ Process design

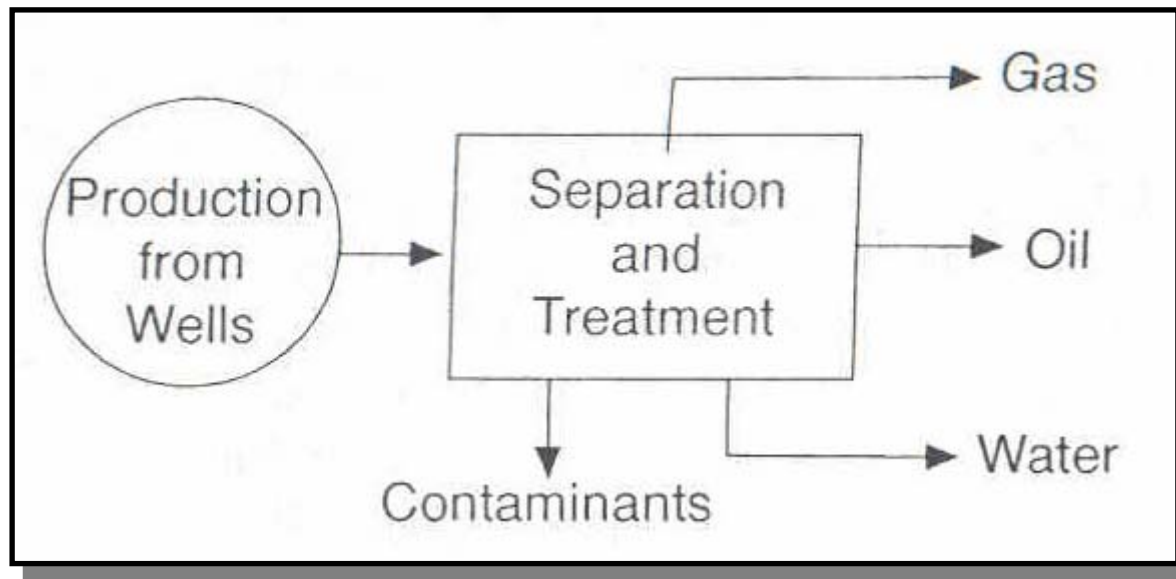

- Description of wellhead fluids: quality & quantity of fluids produced at the wellhead are determined by
 - (1) Hydrocarbon composition
 - (2) Reservoir character
 - (3) Field development scheme

- Hydrocarbon properties which influences process design
 - (1) PVT characteristics
 - (2) Composition
 - (3) Emulsion behavior
 - (4) Viscosity and density

How volumes & rates will change over the life of the well
production profiles → estimate wellhead T,P

- Product specification

- (1) Oil : true vapor pressure , base sediment and water content,
temperature, salinity, hydrogen sulphide content
- (2) Gas : water & HC dew point, HC composition,
contaminants content, heating value
- (3) Water : oil and solids content

- The process model : factors which must be considered

- (1) Product yield
 - (2) Inter-stage P & T
 - (3) Compression power required
 - (4) Cooling & heating requirements
 - (5) Flowrates for equipment sizes
 - (6) Implications of changing production profile
- 

- Process flow schemes

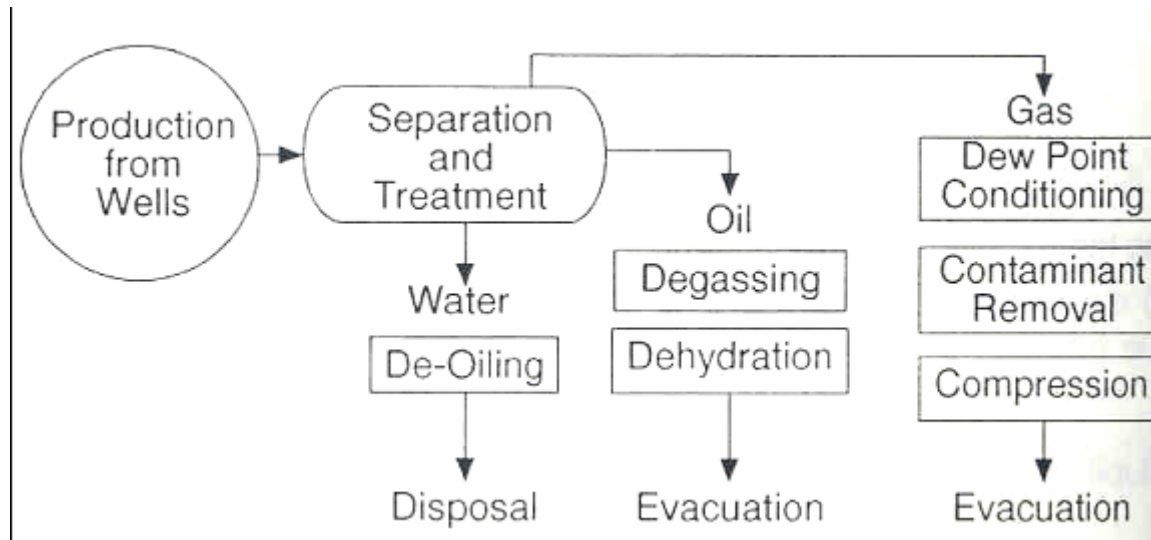

- Use of process flow schemes

- (1) Preparing preliminary equipment lists
- (2) Supporting early cost estimates
- (3) Basic risk analysis

- Describing hydrocarbon composition

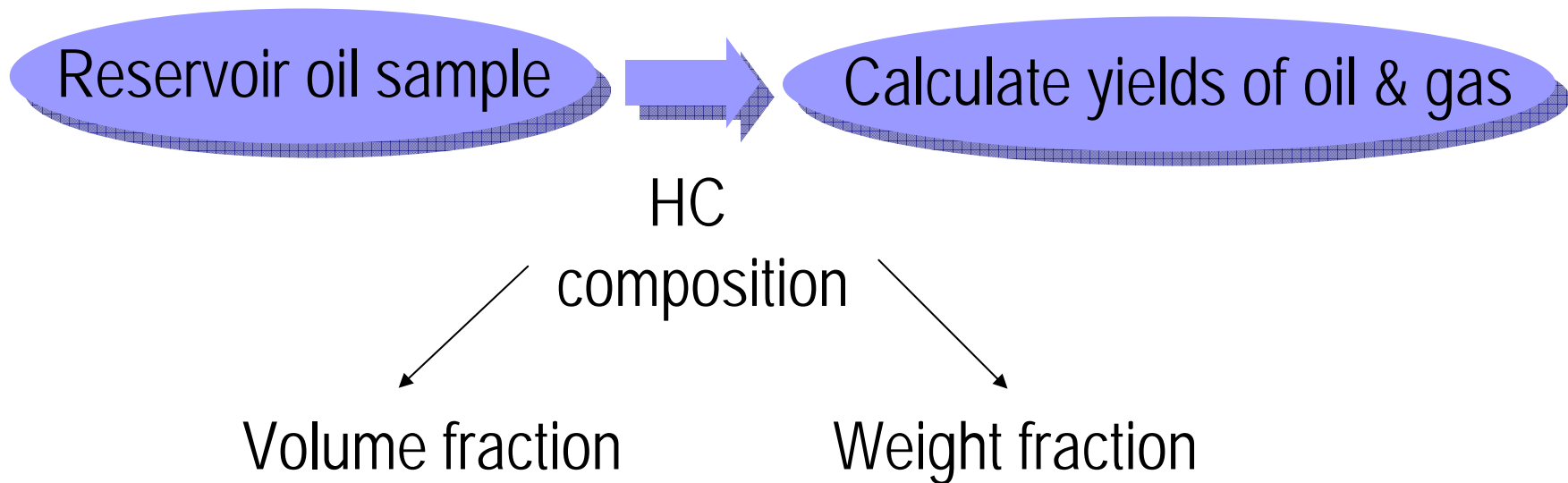

1 Barrel of Gas Type 'X'
(0.63 cu.m)
@ T and P

Volume (or mol) fraction of each component		Volume in cu.m.
CH ₄	0.85	0.53
C ₂ H ₆	0.09	0.06
C ₃ H ₈	0.05	0.03
C ₄ H ₁₀	0.01	0.01
	1.00	0.63

1 Mole of Gas Type 'X'

Volume (or mol) fraction	Molecular Weight (g/mol)	Weight Composition
CH ₄ 0.85	16.04	13.6
C ₂ H ₆ 0.09	30.07	2.7
C ₃ H ₈ 0.05	44.10	2.2
C ₄ H ₁₀ 0.01	58.12	0.6
1.00		19.1 g / mol

Process design

- Separation

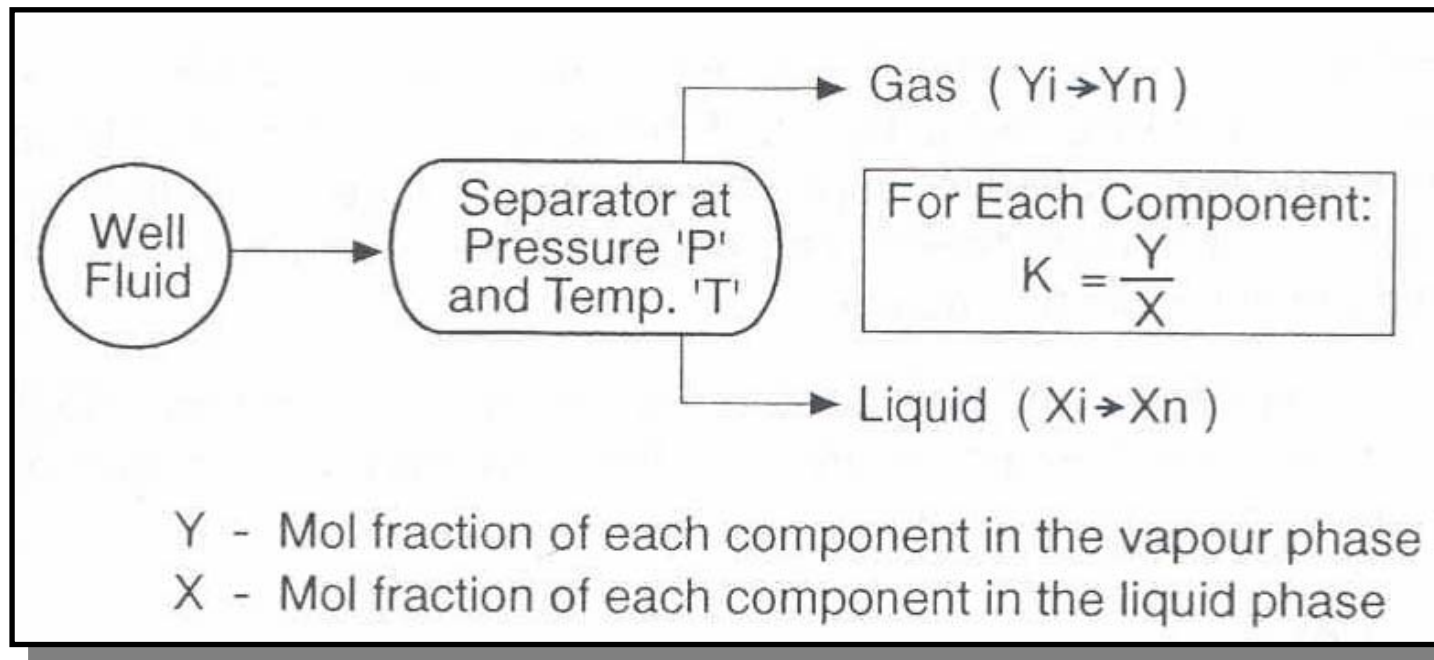

To determine how much of each component goes into the gas or liquid phase, K must be known.

- Separation design

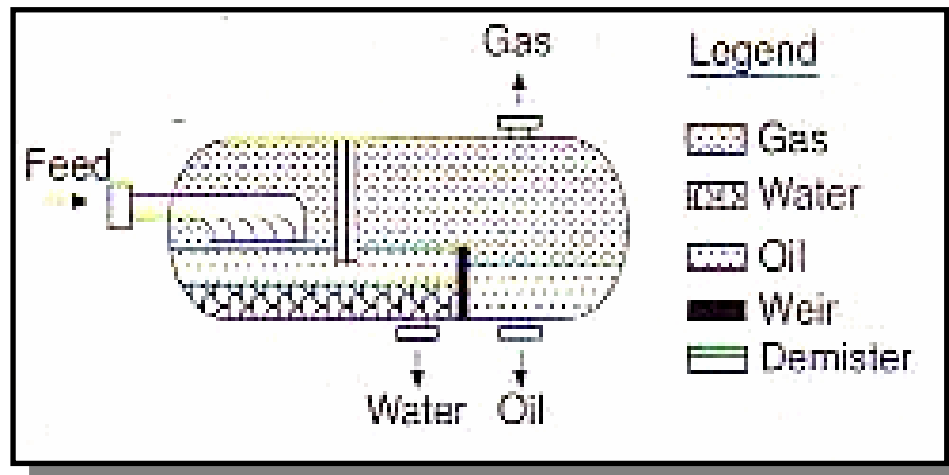

- Demister

- (1) Impingement demister
- (2) Centrifugal demister

- Separation types

(1) Main function

Knockout vessels / Demister separators

(2) Orientation

Horizontal separator

Vertical separator

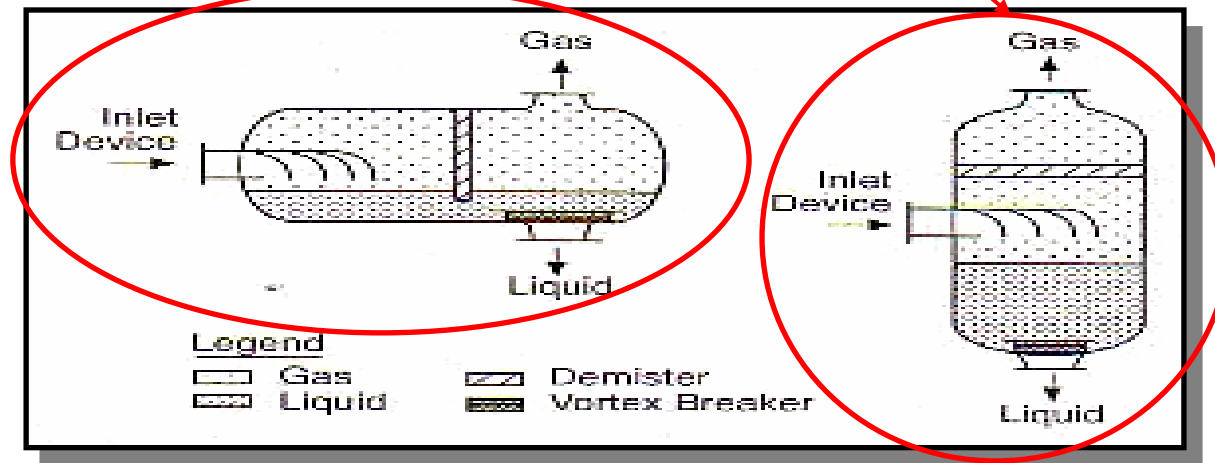

- Dehydration and water treatment

(1) Produced water must be separated from oil .

(2) Oil contained in separated water must be removed .

(3) Method : settling & skimming tank

- Dehydration

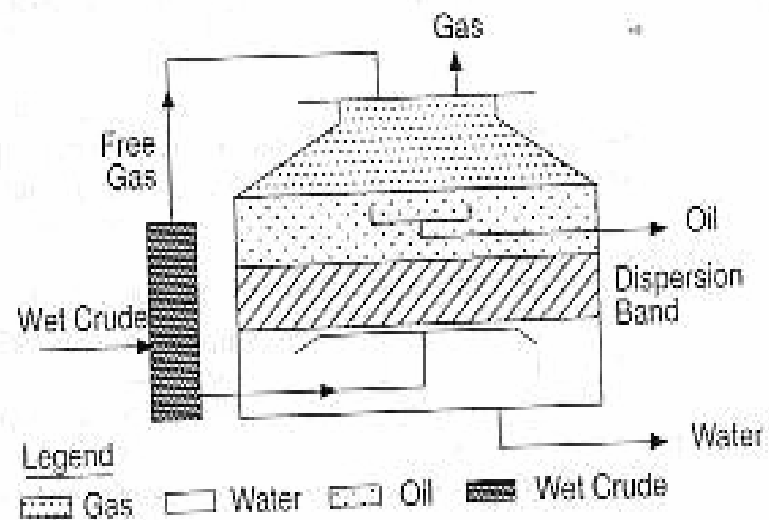

-De-oiling

- (1) Skimming tank vs. Gravity separator
- (2) Oil interceptor : used both offshore & onshore
plate interceptor

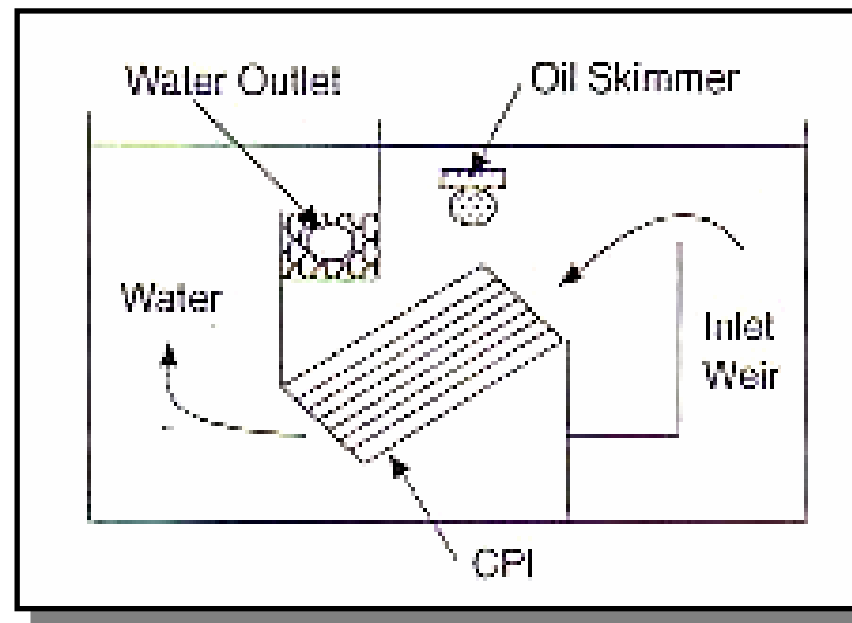

✦ Upstream gas processing

- Components which cause pipeline corrosion or blockage :
water vapor , heavy HC , CO₂ , H₂S
- Associated gas : flared or re-injected
- Pressure reduction : be made across a choke before primary
O/G separator

- Gas dehydration

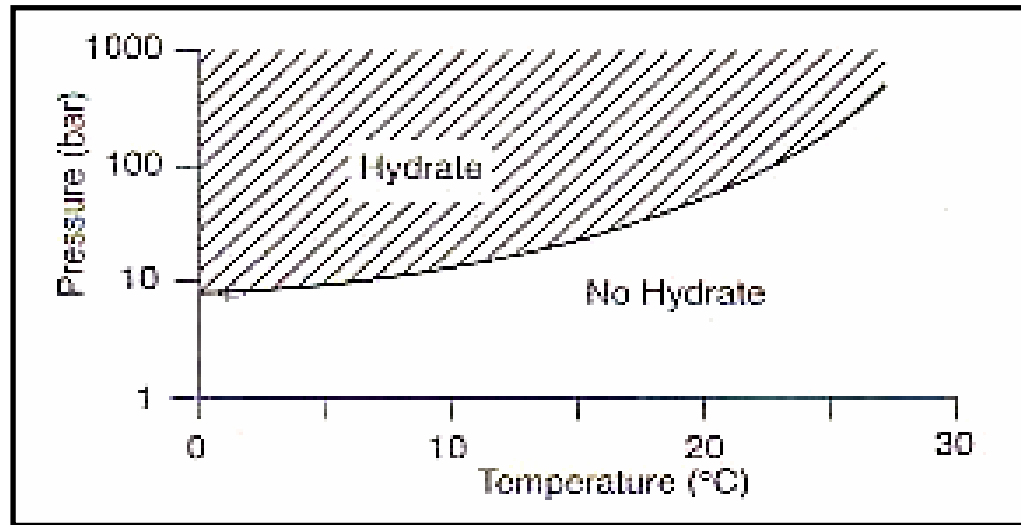

Methods of dehydration :

- (1) Cooling
- (2) Absorption
- (3) Adsorption

- Heavy hydrocarbon removal

(1) High wellhead P over long period

JT throttling / turbo-expander

(2) High P is not available : refrigeration

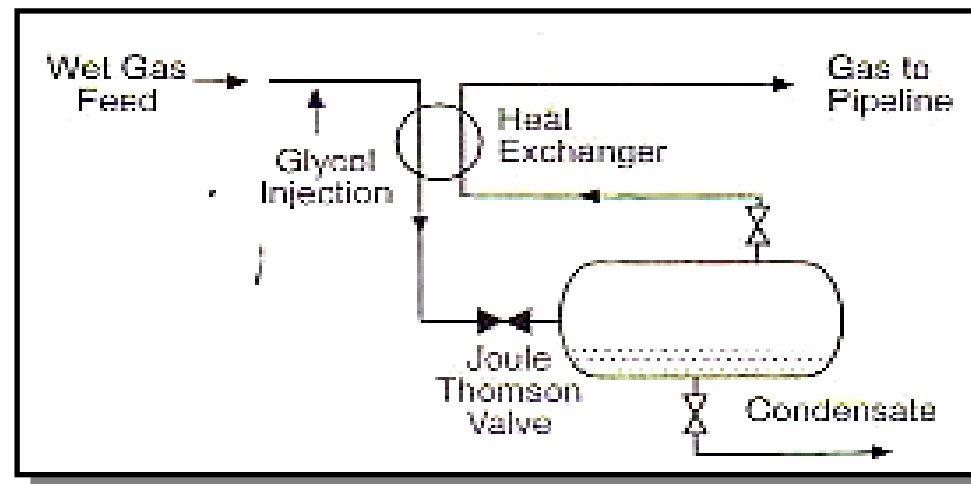

- Contaminant removal

CO₂, H₂S

- Pressure elevation (gas compression)

(1) Reciprocating
compressors

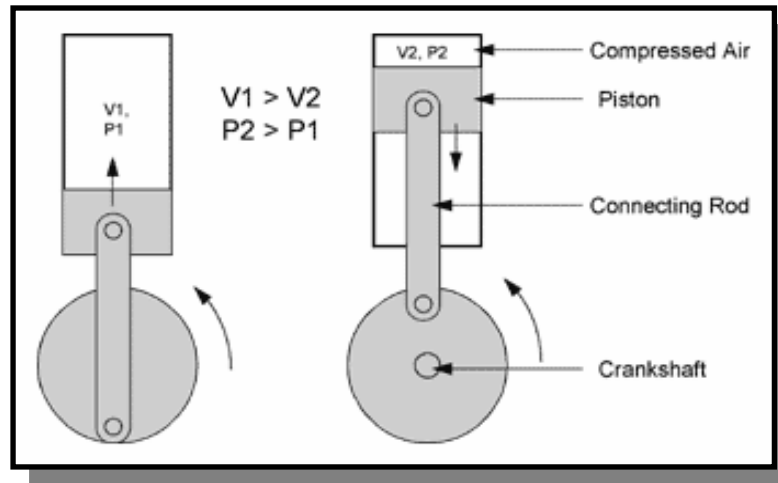

(2) Centrifugal
compressors

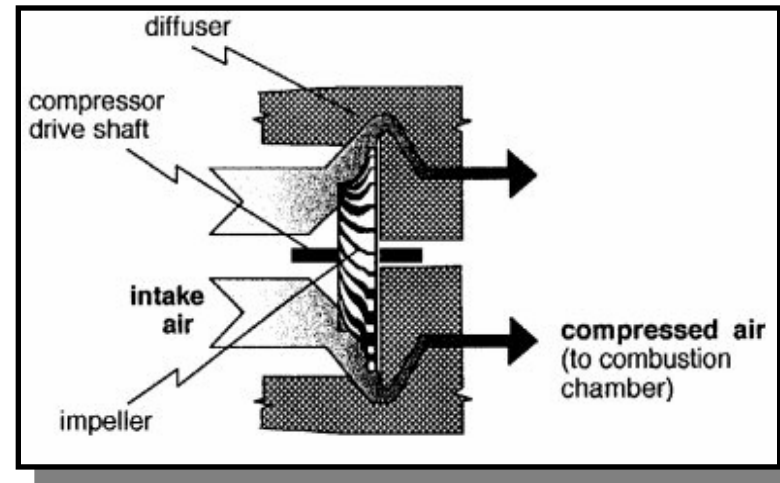

➤ Downstream gas processing

Terminology of natural gas :

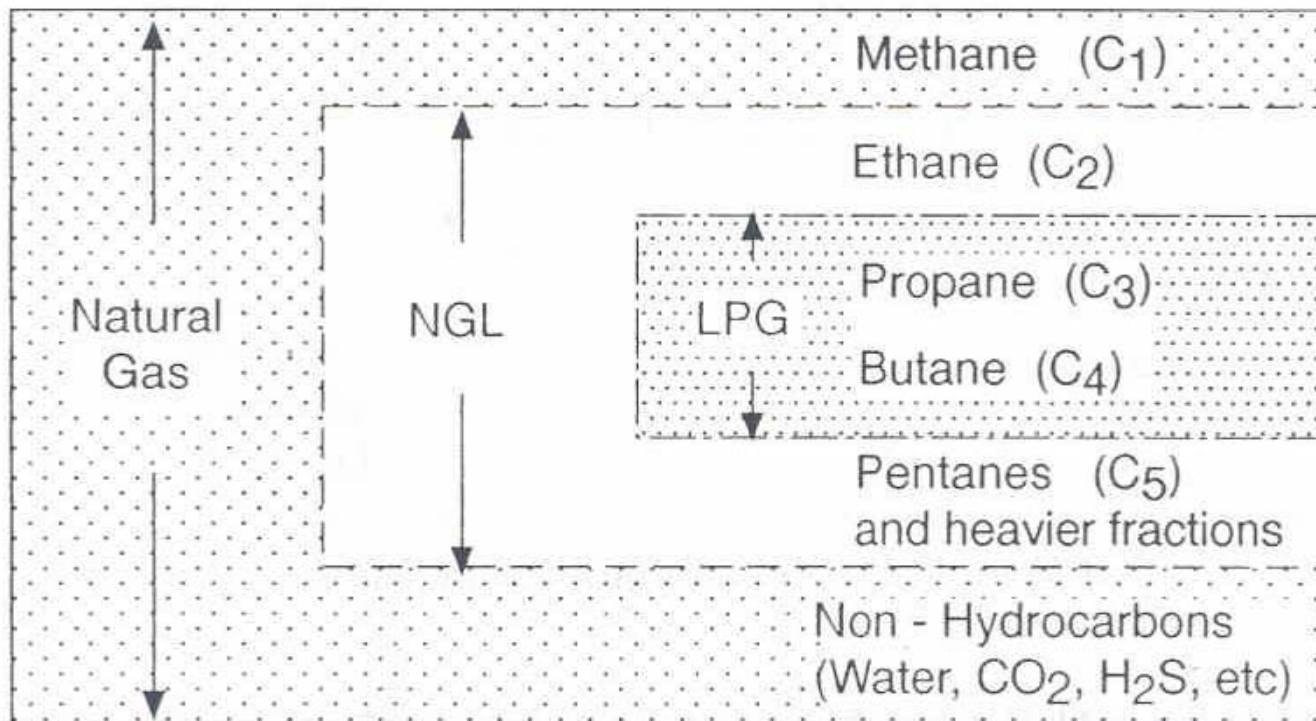

- Contaminant removal

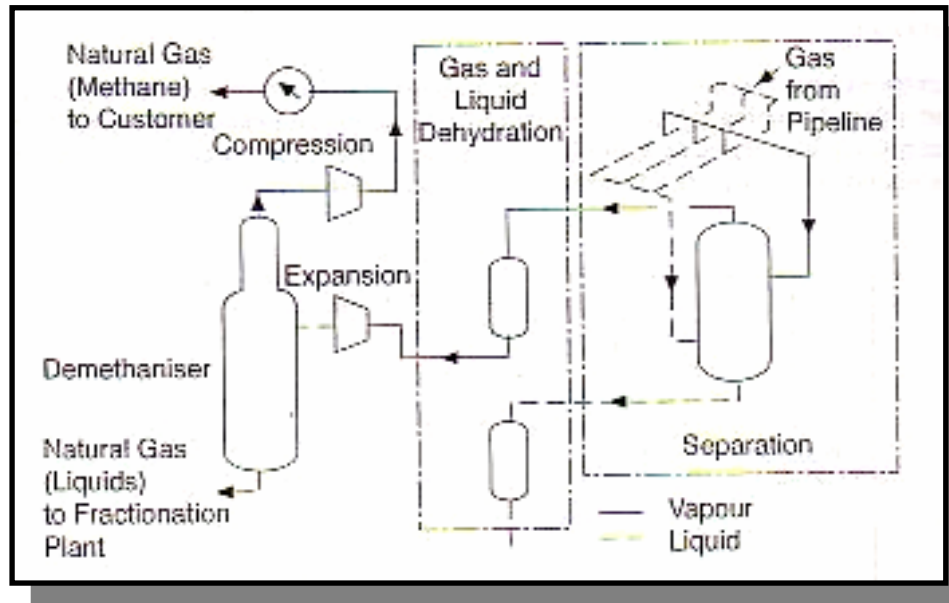

- Natural gas liquid recovery :

When gases rich in C_2H_6 , C_3H_8 , C_4H_{10} & there is a local market, recover those components.

✦ Facilities

✦ Production support systems

- Water injection : principle factors studied in an analysis are
 - (1) Dissolved solids
 - (2) Suspended solids
 - (3) Suspended oil
 - (4) Bacteria
 - (5) Dissolved gases

- Gas injection

- (1) Supplement recovery by maintaining reservoir P

- (2) Dispose gas

- Artificial lift

- (1) Gas lift

- (2) Beam pumping

- (3) Downhole pumping

➤ Land based production facilities

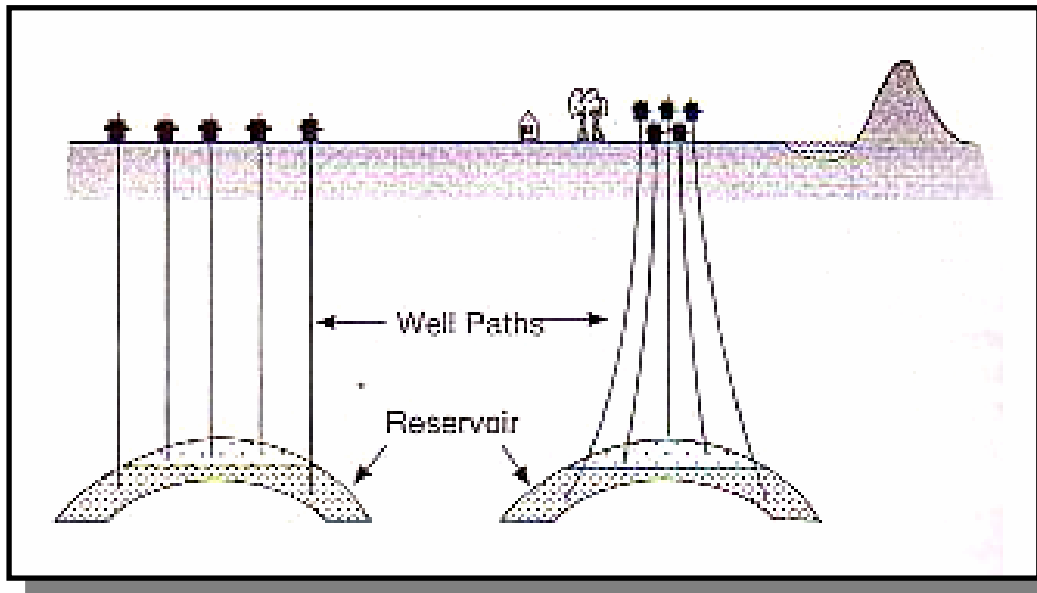

- Wellsites

Allow access for future operations & maintenance activity

- Gathering stations

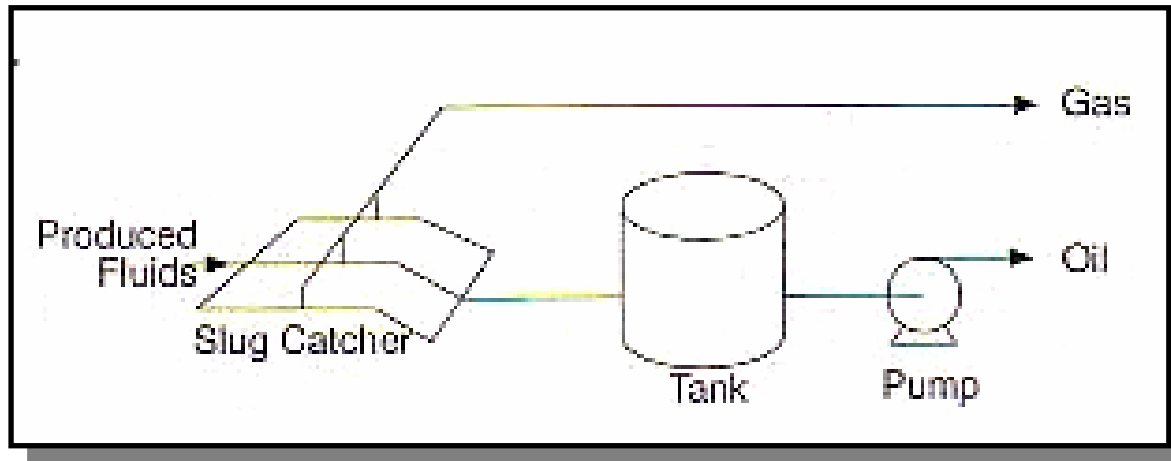

On a land sites, tank type separation equipment is better than vessel type

- Evacuation and storage

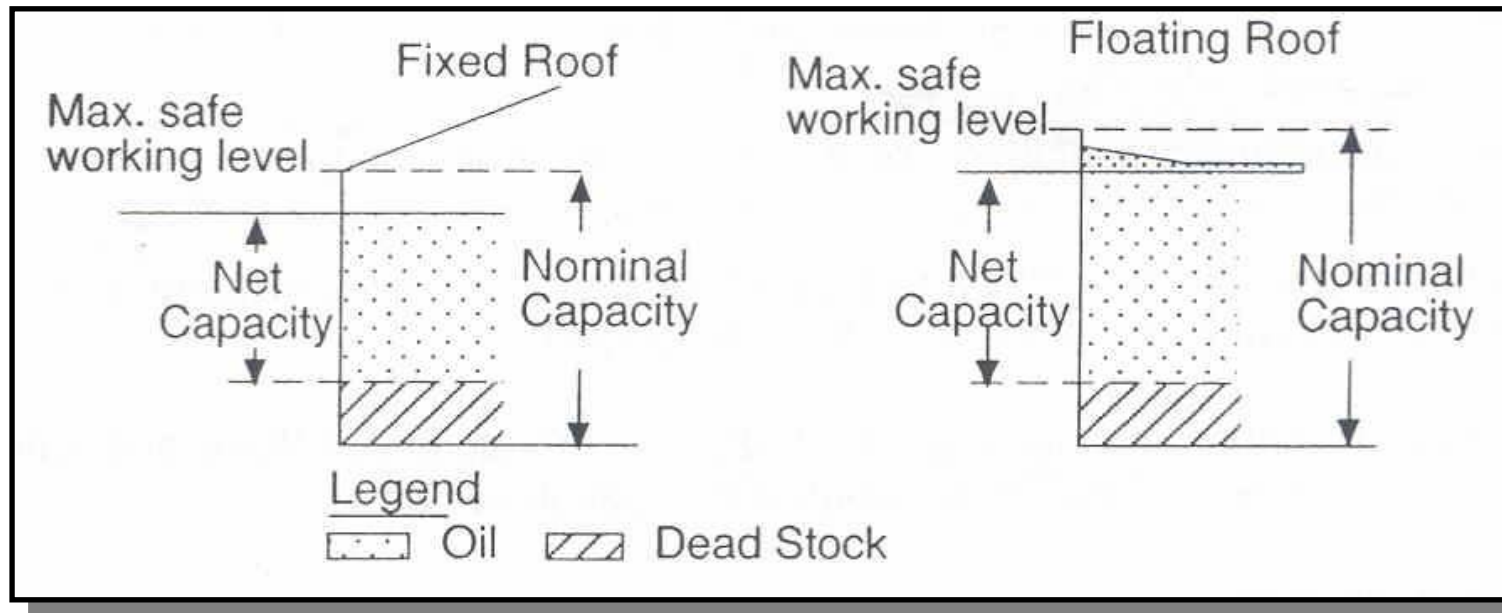

Surface Facilities

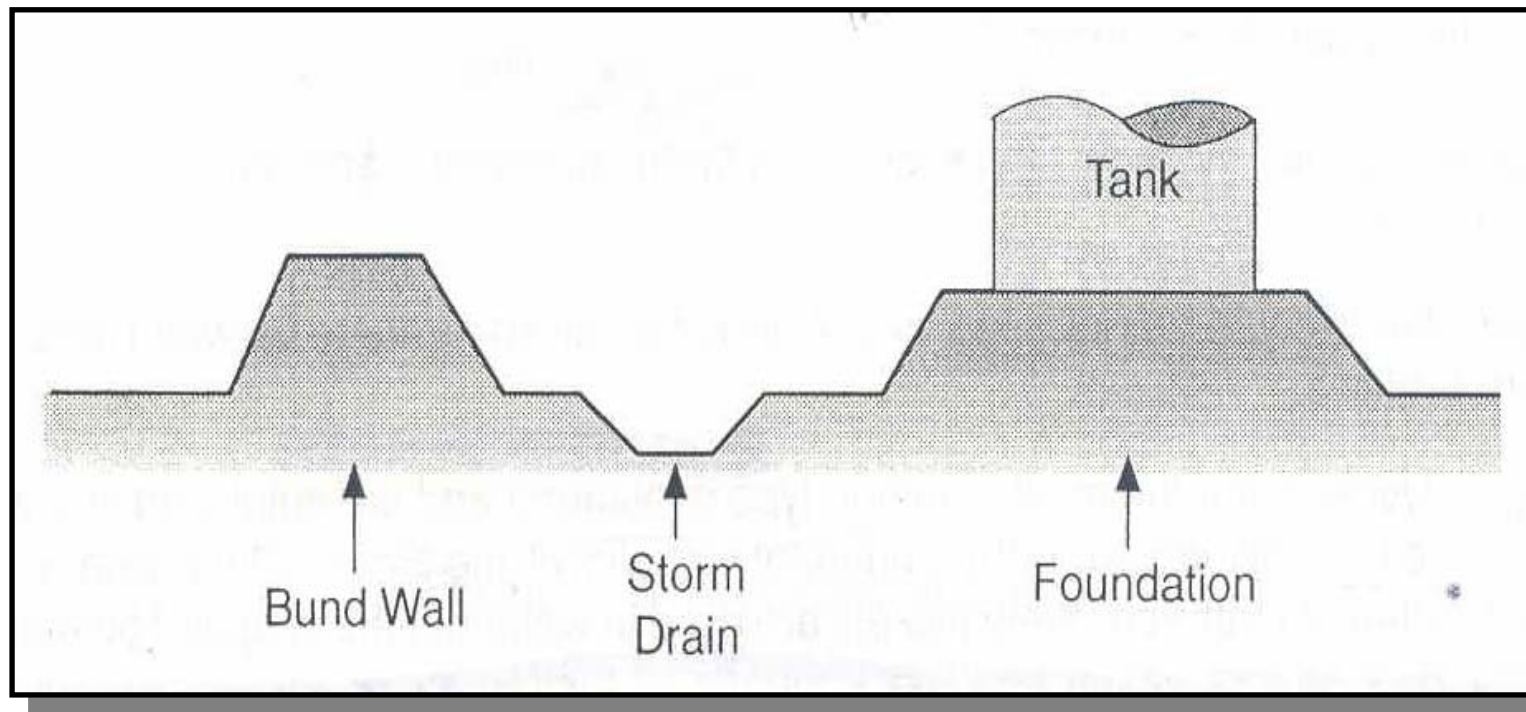

➤ Offshore production facilities

- Offshore platforms
 - (1) Steel jacket platforms
 - (2) Gravity based platforms
 - (3) Tension leg platforms
 - (4) Minimum facility systems

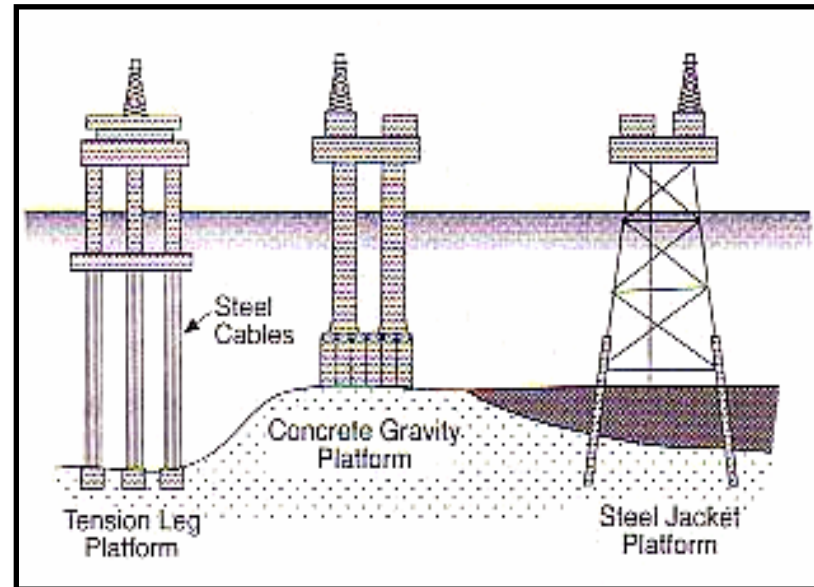

✦ Control systems

- Electro-hydraulic system

- Monopod system
 - (1) Cost effective
 - (2) Limiting factor : water depth

- Offshore evacuation systems

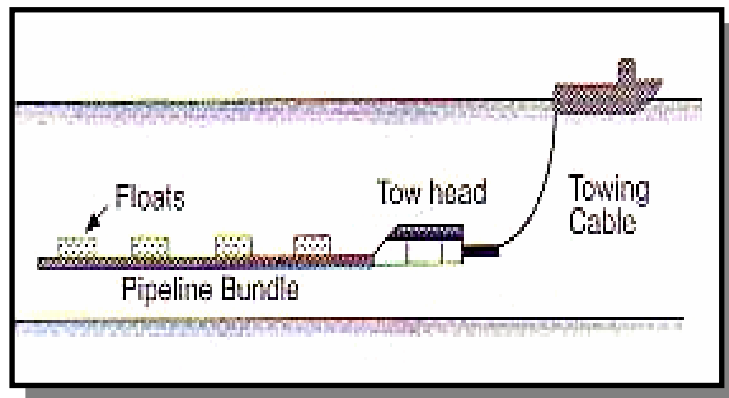

- Offshore loading
- (1) Single Buoy Mooring

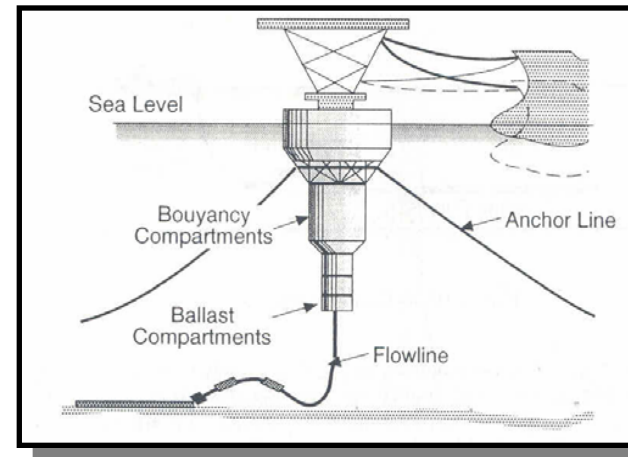

(2) Spar type storage terminal (3) Tanker storage & export

