

Due to above disadvantages, ungrounded neutral system is not used these days. The modern high-voltage 3-phase systems employ grounded neutral owing to a number of advantages.

26.5 Neutral Grounding

The process of connecting neutral point of 3-phase system to earth (i.e. soil) either directly or through some circuit element (e.g. resistance, reactance etc.) is called **neutral grounding**.

Neutral grounding provides protection to personal and equipment. It is because during earth fault, the current path is completed through the earthed neutral and the protective devices (e.g. a fuse etc.) operate to isolate the faulty conductor from the rest of the system. This point is illustrated in Fig. 26.10.

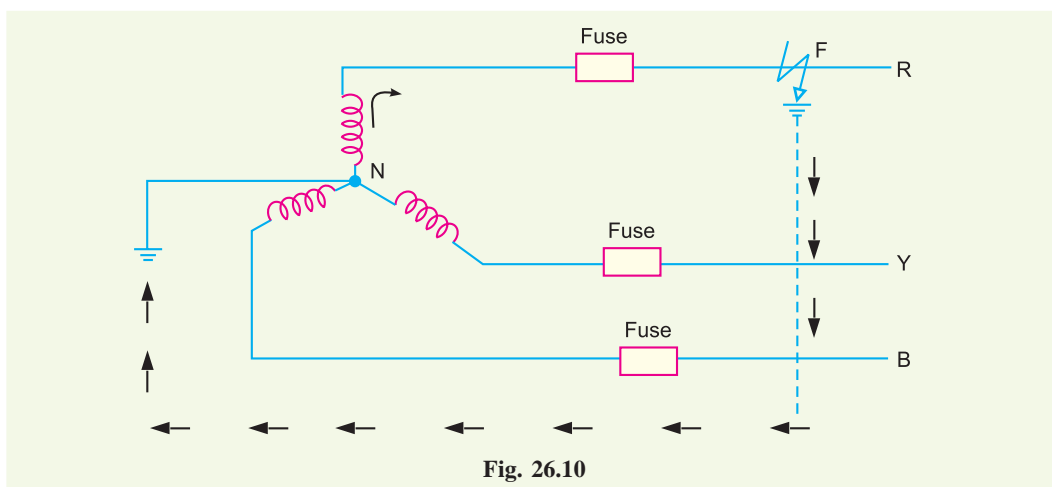

Fig. 26.10

Fig. 26.10 shows a 3-phase, star-connected system with neutral earthed (i.e. neutral point is connected to soil). Suppose a single line to ground fault occurs in line *R* at point *F*. This will cause the current to flow through ground path as shown in Fig. 26.10. Note that current flows from *R*-phase to earth, then to neutral point *N* and back to *R*-phase. Since the impedance of the current path is low, a large current flows through this path. This large current will blow the fuse in *R*-phase and isolate the faulty line *R*. This will protect the system from the harmful effects (e.g. damage to equipment, electric shock to personnel etc.) of the fault. One important feature of grounded neutral is that the potential difference between the live conductor and ground will not exceed the phase voltage of the system i.e. it will remain nearly constant.

26.6 Advantages of Neutral Grounding

The following are the advantages of neutral grounding :

- (i) Voltages of the healthy phases do not exceed line to ground voltages i.e. they remain nearly constant.
- (ii) The high voltages due to arcing grounds are eliminated.
- (iii) The protective relays can be used to provide protection against earth faults. In case earth fault occurs on any line, the protective relay will operate to isolate the faulty line.
- (iv) The overvoltages due to lightning are discharged to earth.
- (v) It provides greater safety to personnel and equipment.
- (vi) It provides improved service reliability.
- (vii) Operating and maintenance expenditures are reduced.

Note : It is interesting to mention here that ungrounded neutral has the following advantages :

- (i) In case of earth fault on one line, the two healthy phases will continue to supply load for a short period.
- (ii) Interference with communication lines is reduced because of the absence of zero sequence currents.

The advantages of ungrounded neutral system are of negligible importance as compared to the advantages of the grounded neutral system. Therefore, modern 3-phase systems operate with grounded neutral points.

26.7 Methods of Neutral Grounding

The methods commonly used for grounding the neutral point of a 3-phase system are :

- (i) Solid or effective grounding
- (ii) Resistance grounding
- (iii) Reactance grounding
- (iv) Peterson-coil grounding

The choice of the method of grounding depends upon many factors including the size of the system, system voltage and the scheme of protection to be used.

26.8 Solid Grounding

When the neutral point of a 3-phase system (e.g. 3-phase generator, 3-phase transformer etc.) is directly *connected to earth (i.e. soil) through a wire of negligible resistance and reactance, it is called **solid grounding or effective grounding**.

Fig. 26.11 shows the solid grounding of the neutral point. Since the neutral point is directly connected to earth through a wire, the neutral point is held at earth potential under all conditions. Therefore, under fault conditions, the voltage of any conductor to earth will not exceed the normal phase voltage of the system.

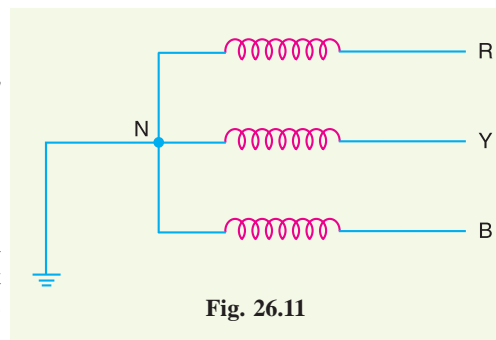

Fig. 26.11

Advantages. The solid grounding of neutral point has the following advantages :

- (i) The neutral is effectively held at earth potential.

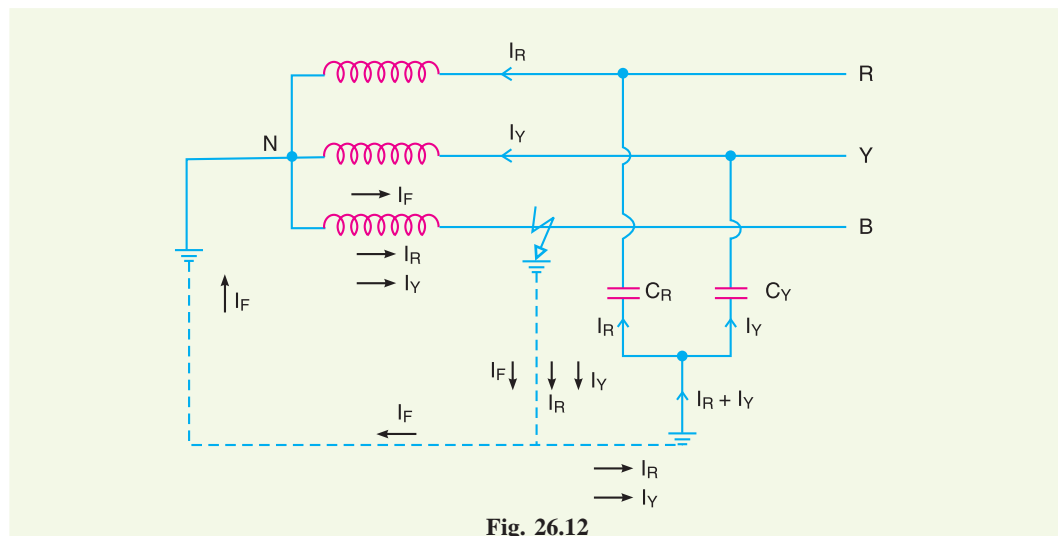

Fig. 26.12

* This is a metallic connection made from the neutral of the system to one or more earth electrodes consisting of plates, rods or pipes buried in the ground.

- (ii) When earth fault occurs on any phase, the resultant capacitive current I_C is in phase opposition to the fault current I_F . The two currents completely cancel each other. Therefore, no arcing ground or over-voltage conditions can occur. Consider a line to ground fault in line B as shown in Fig. 26.12. The capacitive currents flowing in the healthy phases R and Y are I_R and I_Y respectively. The resultant capacitive current I_C is the phasor sum of I_R and I_Y . In addition to these capacitive currents, the power source also supplies the fault current I_F . This fault current will go from fault point to earth, then to neutral point N and back to the fault point through the faulty phase. The path of I_C is capacitive and that of I_F is inductive. The two currents are in phase opposition and completely cancel each other. Therefore, no arcing ground phenomenon or over-voltage conditions can occur.
- (iii) When there is an earth fault on any phase of the system, the phase to earth voltage of the faulty phase becomes zero. However, the phase to earth voltages of the remaining two healthy phases remain at normal phase voltage because the potential of the neutral is fixed at earth potential. This permits to insulate the equipment for phase voltage. Therefore, there is a saving in the cost of equipment.
- (iv) It becomes easier to protect the system from earth faults which frequently occur on the system. When there is an earth fault on any phase of the system, a large fault current flows between the fault point and the grounded neutral. This permits the easy operation of earth-fault relay.

Disadvantages. The following are the disadvantages of solid grounding :

- (i) Since most of the faults on an overhead system are phase to earth faults, the system has to bear a large number of severe shocks. This causes the system to become unstable.
- (ii) The solid grounding results in heavy earth fault currents. Since the fault has to be cleared by the circuit breakers, the heavy earth fault currents may cause the burning of circuit breaker contacts.
- (iii) The increased earth fault current results in greater interference in the neighbouring communication lines.

Applications. Solid grounding is usually employed where the circuit impedance is sufficiently high so as to keep the earth fault current within safe limits. This system of grounding is used for voltages upto 33 kV with total power capacity not exceeding 5000 kVA.

26.9 Resistance Grounding

In order to limit the magnitude of earth fault current, it is a common practice to connect the neutral point of a 3-phase system to earth through a resistor. This is called *resistance grounding*.

When the neutral point of a 3-phase system (e.g. 3-phase generator, 3-phase transformer etc.) is connected to earth (i.e. soil) through a resistor, it is called **resistance grounding**.

Fig. 26.13 shows the grounding of neutral point through a resistor R . The value of R should neither be very low nor very high. If the value of earthing resistance R is very low, the earth fault current will be large and the system becomes similar to the solid grounding system. On the other hand, if the earthing resistance R is very high, the system conditions become similar to ungrounded

* By symmetrical components, the fault current I_F is given by :

$$I_F = \frac{3V_{ph}}{Z_1 + Z_2 + Z_0}$$

Since $Z_1 + Z_2 + Z_0$ is predominantly inductive, I_F lags behind the phase to neutral voltage of the faulted phase by nearly 90° .

** It may be a metallic resistor or liquid resistor. Metallic resistors do not change with time and practically require no maintenance. However, a metallic resistor is slightly inductive and this poses a problem with overhead lines exposed to lightning. Liquid resistors are free from this disadvantage.

neutral system. The value of R is so chosen such that the earth fault current is limited to safe value but still sufficient to permit the operation of earth fault protection system. In practice, that value of R is selected that limits the earth fault current to 2 times the normal full load current of the earthed generator or transformer.

Advantages. The following are the advantages of resistance earthing:

- (i) By adjusting the value of R , the arcing grounds can be minimised. Suppose earth fault occurs in phase B as shown in Fig. 26.14. The capacitive currents I_R and I_Y flow in the healthy phases R and Y respectively. The fault current I_F lags behind the phase voltage of the faulted phase by a certain angle depending upon the earthing resistance R and the reactance of the system upto the point of fault. The fault current I_F can be resolved into two components *viz.*

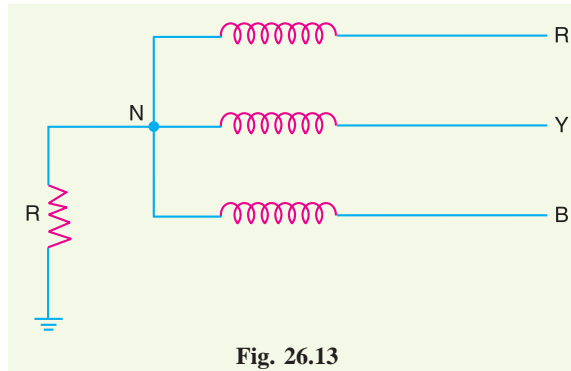

Fig. 26.13

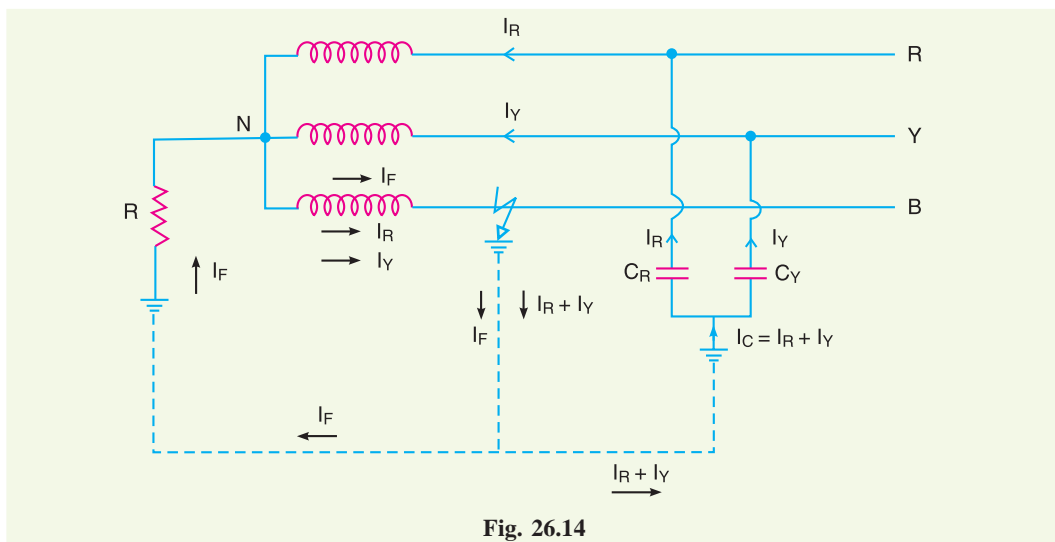

Fig. 26.14

- (a) I_{F1} in phase with the faulty phase voltage.
- (b) I_{F2} lagging behind the faulty phase voltage by 90° .

The lagging component I_{F2} is in phase opposition to the total capacitive current I_C . If the value of earthing resistance R is so adjusted that $I_{F2} = I_C$, the arcing ground is completely eliminated and the operation of the system becomes that of solidly grounded system. However, if R is so adjusted that $I_{F2} < I_C$, the operation of the system becomes that of ungrounded neutral system.

- (ii) The earth fault current is small due to the presence of earthing resistance. Therefore, interference with communication circuits is reduced.
- (iii) It improves the stability of the system.

Disadvantages. The following are the disadvantages of resistance grounding :

- (i) Since the system neutral is displaced during earth faults, the equipment has to be insulated for higher voltages.
- (ii) This system is costlier than the solidly grounded system.

(iii) A large amount of energy is produced in the earthing resistance during earth faults. Sometimes it becomes difficult to dissipate this energy to atmosphere.

Applications. It is used on a system operating at voltages between 2.2 kV and 33 kV with power source capacity more than 5000 kVA.

26.10 Reactance Grounding

In this system, a reactance is inserted between the neutral and ground as shown in Fig. 26.15. The purpose of reactance is to limit the earth fault current. By changing the earthing reactance, the earth fault current can be changed to obtain the conditions similar to that of solid grounding. This method is not used these days because of the following disadvantages :

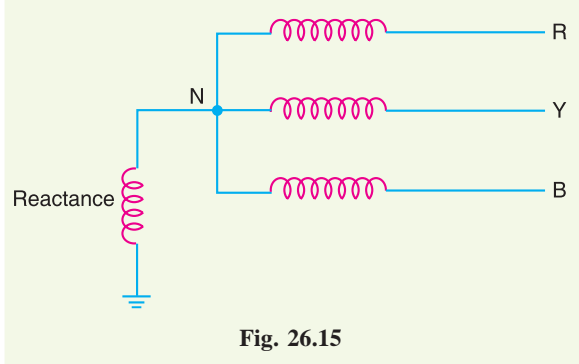

Fig. 26.15

- (i) In this system, the fault current required to operate the protective device is higher than that of resistance grounding for the same fault conditions.
- (ii) High transient voltages appear under fault conditions.

26.11 *Arc Suppression Coil Grounding (or Resonant Grounding)

We have seen that capacitive currents are responsible for producing arcing grounds. These capacitive currents flow because capacitance exists between each line and earth. If inductance L of appropriate value is connected in parallel with the capacitance of the system, the fault current I_F flowing through L will be in phase opposition to the capacitive current I_C of the system. If L is so adjusted that $I_L = I_C$, then resultant current in the fault will be zero. This condition is known as *resonant grounding*.

When the value of L of arc suppression coil is such that the fault current I_F exactly balances the capacitive current I_C , it is called **resonant grounding**.

Circuit details. An arc suppression coil (also called **Peterson coil**) is an iron-cored coil connected between the neutral and earth as shown in Fig. 26.16(i). The reactor is provided with tapplings to change the inductance of the coil. By adjusting the tapplings on the coil, the coil can be tuned with the capacitance of the system i.e. resonant grounding can be achieved.

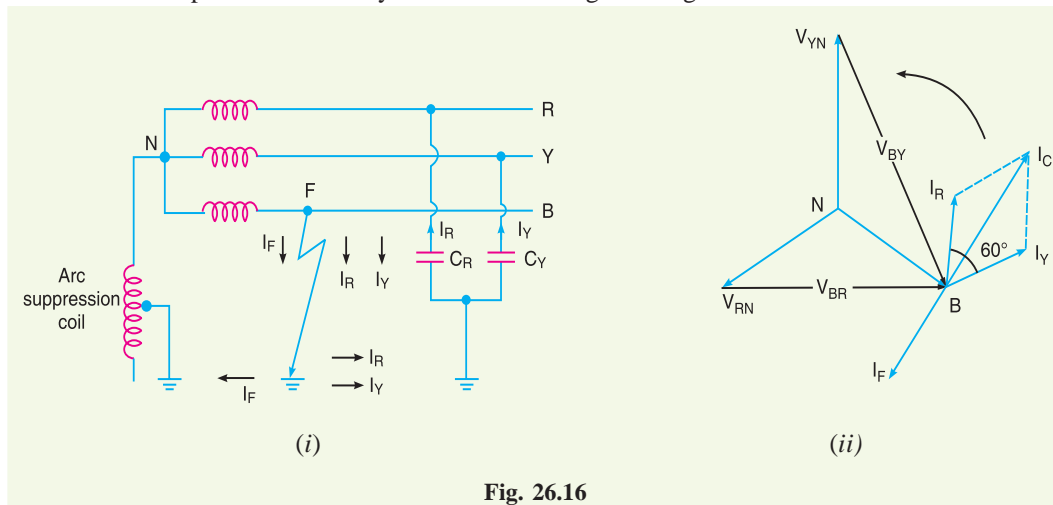

Fig. 26.16

* Also called **Peterson coil grounding**.

Operation. Fig. 26.16(i) shows the 3-phase system employing Peterson coil grounding. Suppose line to ground fault occurs in the line B at point F . The fault current I_F and capacitive currents I_R and I_Y will flow as shown in Fig. 26.16(i). Note that I_F flows through the Peterson coil (or Arc suppression coil) to neutral and back through the fault. The total capacitive current I_C is the phasor sum of I_R and I_Y as shown in phasor diagram in Fig. 26.16(ii). The voltage of the faulty phase is applied across the arc suppression coil. Therefore, fault current I_F lags the faulty phase voltage by 90° . The current I_F is in phase opposition to capacitive current I_C [See Fig. 26.16(ii)]. By adjusting the tapings on the Peterson coil, the resultant current in the fault can be reduced. If inductance of the coil is so adjusted that $I_L = I_C$, then resultant current in the fault will be zero.

Value of L for resonant grounding. For resonant grounding, the system behaves as an ungrounded neutral system. Therefore, full line voltage appears across capacitors C_R and C_Y .

$$\therefore I_R = I_Y = \frac{\sqrt{3}V_{ph}}{X_C}$$

$$\therefore I_C = \sqrt{3} I_R = \sqrt{3} \times \frac{\sqrt{3}V_{ph}}{X_C} = \frac{3V_{ph}}{X_C}$$

Here, X_C is the line to ground capacitive reactance.

$$\text{Fault current, } I_F = \frac{V_{ph}}{X_L}$$

Here, X_L is the inductive reactance of the arc suppression coil.

For resonant grounding, $I_L = I_C$.

$$\text{or } \frac{V_{ph}}{X_L} = \frac{3V_{ph}}{X_C}$$

$$\text{or } X_L = \frac{X_C}{3}$$

$$\text{or } \omega L = \frac{1}{3\omega C}$$

$$\therefore L = \frac{1}{3\omega^2 C} \quad \dots(i)$$

Exp. (i) gives the value of inductance L of the arc suppression coil for resonant grounding.

Advantages. The Peterson coil grounding has the following advantages:

- (i) The Peterson coil is completely effective in preventing any damage by an arcing ground.
- (ii) The Peterson coil has the advantages of ungrounded neutral system.

Disadvantages. The Peterson coil grounding has the following disadvantages :

- (i) Due to varying operational conditions, the capacitance of the network changes from time to time. Therefore, inductance L of Peterson coil requires readjustment.
- (ii) The lines should be transposed.

26.12 Voltage Transformer Earthing

In this method of neutral earthing, the primary of a single-phase voltage transformer is connected between the neutral and the earth as shown in Fig. 26.17. A low resistor in series with a relay is connected across the secondary of the voltage transformer. The voltage transformer provides a high reactance in the neutral earthing circuit and operates virtually as an ungrounded neutral system. An

earth fault on any phase produces a voltage across the relay. This causes the operation of the protective device.

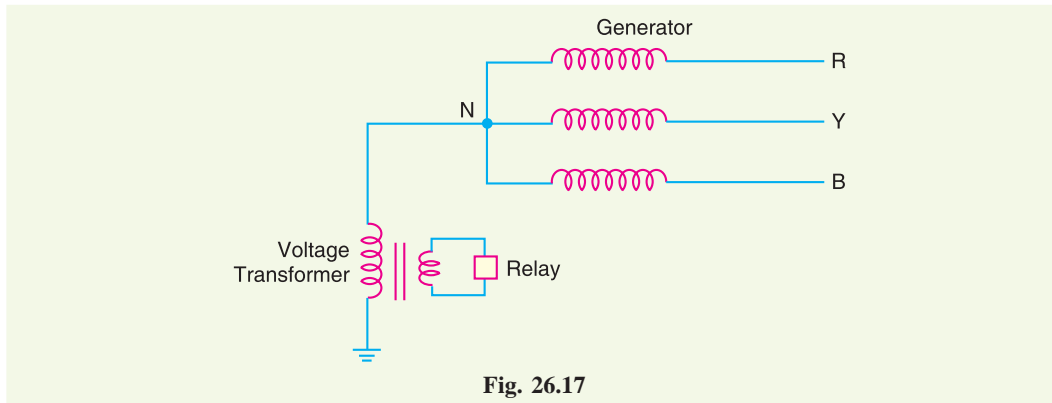

Fig. 26.17

Advantages. The following are the advantages of voltage transformer earthing :

- (i) The transient overvoltages on the system due to switching and arcing grounds are reduced. It is because voltage transformer provides high reactance to the earth path.
- (ii) This type of earthing has all the advantages of ungrounded neutral system.
- (iii) Arcing grounds are eliminated.

Disadvantages. The following are the disadvantages of voltage transformer earthing :

- (i) When earth fault occurs on any phase, the line voltage appears across line to earth capacitances. The system insulation will be overstressed.
- (ii) The earthed neutral acts as a reflection point for the travelling waves through the machine winding. This may result in high voltage build up.

Applications. The use of this system of neutral earthing is normally confined to generator equipments which are directly connected to step-up power transformers.

Example 26.1. Calculate the reactance of Peterson coil suitable for a 33 kV, 3-phase transmission line having a capacitance to earth of each conductor as $4.5 \mu\text{F}$. Assume supply frequency to be 50 Hz.

Solution. Supply frequency, $f = 50 \text{ Hz}$

Line to earth capacitance, $C = 4.5 \mu\text{F} = 4.5 \times 10^{-6} \text{ F}$

For Peterson coil grounding, reactance X_L of the Peterson coil should be equal to $X_C / 3$ where X_C is line to earth capacitive reactance.

$$\begin{aligned} \therefore \text{Reactance of Peterson coil, } X_L &= \frac{X_C}{3} = \frac{1}{3 \omega C} = \frac{1}{3 \times 2\pi f \times C} \\ &= \frac{1}{3 \times 2\pi \times 50 \times 4.5 \times 10^{-6}} = 235.8 \Omega \end{aligned}$$

Example 26.2. A 230 kV, 3-phase, 50 Hz, 200 km transmission line has a capacitance to earth of $0.02 \mu\text{F}/\text{km}$ per phase. Calculate the inductance and kVA rating of the Peterson coil used for earthing the above system.

Solution. Supply frequency, $f = 50 \text{ Hz}$

Capacitance of each line to earth, $C = 200 \times 0.02 = 4 \times 10^{-6} \text{ F}$

Required inductance of Peterson coil is

$$L = \frac{1}{3\omega^2 C}$$

$$= \frac{1}{3 \times (2\pi \times 50)^2 \times 4 \times 10^{-6}} = \mathbf{0.85 \text{ H}}$$

Current through Peterson coil is

$$I_F = \frac{V_{ph}}{X_L} = \frac{230 \times 10^3 / \sqrt{3}}{2\pi \times 50 \times 0.85} = 500 \text{ A}$$

Voltage across Peterson coil is

$$V_{ph} = \frac{V_L}{\sqrt{3}} = \frac{230 \times 1000}{\sqrt{3}} \text{ V}$$

$$\therefore \text{Rating of Peterson coil} = V_{ph} \times I_F = \frac{230 \times 1000}{\sqrt{3}} \times 500 \times \frac{1}{1000} \text{ kVA} = \mathbf{66397 \text{ kVA}}$$

Example 26.3. A 50 Hz overhead line has line to earth capacitance of 1.2 μF . It is desired to use *earth fault neutralizer. Determine the reactance to neutralize the capacitance of (i) 100% of the length of the line (ii) 90% of the length of the line and (iii) 80% of the length of the line.

Solution.

(i) Inductive reactance of the coil to neutralize capacitance of 100% of the length of the line is

$$X_L = \frac{1}{3\omega C} = \frac{1}{3 \times 2\pi \times 50 \times 1.2 \times 10^{-6}} = \mathbf{884.19\Omega}$$

(ii) Inductive reactance of the coil to neutralize capacitance of 90% of the length of the line is

$$X_L = \frac{1}{3\omega \times 0.9C} = \frac{1}{3 \times 2\pi \times 50 \times 0.9 \times 1.2 \times 10^{-6}} = \mathbf{982.43\Omega}$$

(iii) Inductive reactance of the coil to neutralize capacitance of 80% of the length of the line is

$$X_L = \frac{1}{3\omega \times 0.8C} = \frac{1}{3 \times 2\pi \times 50 \times 0.8 \times 1.2 \times 10^{-6}} = \mathbf{1105.24\Omega}$$

Example 26.4. A 132 kV, 3-phase, 50 Hz transmission line 200 km long consists of three conductors of effective diameter 20 mm arranged in a vertical plane with 4 m spacing and regularly transposed. Find the inductance and kVA rating of the arc suppression coil in the system.

Solution. Radius of conductor, $r = 20/2 = 10 \text{ mm} = 0.01 \text{ m}$

Conductor spacing, $d = 4 \text{ m}$

\therefore Capacitance between phase and neutral or earth

$$= \frac{2\pi\epsilon_0}{\log_e \frac{d}{r}} \text{ F/m} = \frac{2\pi \times 8.885 \times 10^{-12}}{\log_e \frac{4}{0.01}} = 9.285 \times 10^{-12} \text{ F/m}$$

$$= 9.285 \times 10^{-12} \times 10^3 \text{ F/km} = 9.285 \times 10^{-9} \text{ F/km}$$

\therefore Capacitance C between phase and earth for 200 km line is

* Note that Peterson coil is also known as earth fault neutralizer.

$$C = 200 \times 9.285 \times 10^{-9} = 18.57 \times 10^{-7} \text{ F}$$

The required inductance L of the arc suppression coil is

$$L = \frac{1}{3\omega^2 C} = \frac{1}{3 \times (2\pi \times 50)^2 \times 18.57 \times 10^{-7}} = \mathbf{1.82 \text{ H}}$$

Current through the coil, $I_F = \frac{V_{ph}}{X_L} = \frac{132 \times 10^3 / \sqrt{3}}{2\pi \times 50 \times 1.82} = 132 \text{ A}$

$$\therefore \text{Rating of the coil} = V_{ph} \times I_F = \frac{132}{\sqrt{3}} \times 132 = \mathbf{10060 \text{ kVA}}$$

TUTORIAL PROBLEMS

1. A 132 kV, 3-phase, 50 Hz transmission line 192 km long consists of three conductors of effective diameter 20 mm, arranged in a vertical plane with 4 m spacing and regularly transposed. Find the inductance and MVA rating of the arc suppression coil in the system. **[1.97H; 9.389 MVA]**
2. A 33 kV, 50 Hz network has a capacitance to neutral of 1.0 μF per phase. Calculate the reactance of an arc suppression coil suitable for the system to avoid adverse effect of arching ground. **[1061 Ω]**
3. A transmission line has a capacitance of 0.1 μF per phase. Determine the inductance of Peterson coil to neutralize the effect of capacitance of (i) complete length of the line, (ii) 97% of the line, (iii) 90% length of the line. The supply frequency is 50 Hz. **[(i) 33.80H (ii) 34.84H (iii) 37.55H]**

26.13 Grounding Transformer

We sometimes have to create a neutral point on a 3-phase, 3-wire system (e.g. delta connection etc.) to change it into 3-phase, 4-wire system. This can be done by means of a *grounding transformer*. It is a core type transformer having three limbs built in the same fashion as that of the power transformer. Each limb of the transformer has two identical windings wound differentially (i.e. directions of current in the two windings on each limb are opposite to each other) as shown in Fig. 26.18. Under normal operating conditions, the total flux in each limb is negligibly small. Therefore, the transformer draws very small magnetising current.

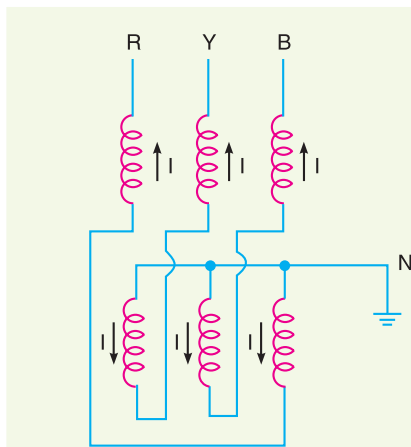

Fig. 26.18

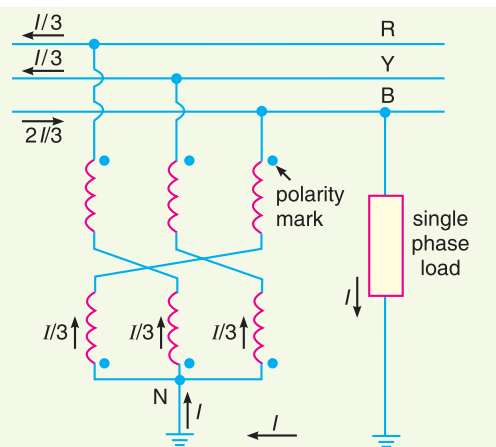

Fig. 26.19

Fig. 26.19 shows the use of grounding transformer to create neutral point N . If we connect a single-phase load between one line and neutral, the load current I divides into three equal currents in each winding. Because the currents are equal, the neutral point stays fixed and the line to neutral

voltages remain balanced as they would be on a regular 4-wire system. In practice, the single-phase loads are distributed as evenly as possible between the three phases and neutral so that unbalanced load current I is relatively small.

The impedance of grounding transformer is quite low. Therefore, when line to earth fault occurs, the fault current will be quite high. The magnitude of fault current is limited by inserting a resistance (not shown in the figure) in the neutral circuit. Under normal conditions, only iron losses will be continuously occurring in the grounding transformer. However, in case of fault, the high fault current will also produce copper losses in the transformer. Since the duration of the fault current is generally between 30-60 seconds, the copper losses will occur only for a short interval.



Grounded Transformer

SELF - TEST

1. Fill in the blanks by inserting appropriate words/figures :

- (i) When single line to earth fault occurs on an ungrounded neutral system, the voltages of the healthy phases (other than the faulty phase) rise from their normal phase voltages to
- (ii) When single line to earth fault occurs on an ungrounded neutral system, the capacitive current in the two healthy phases rises to times the normal value.
- (iii) When single line to earth fault occurs on an ungrounded neutral system, the capacitive fault current becomes times the normal per phase capacitive current.
- (iv) In Peterson coil grounding, inductance L of the coil is related to line to earth capacitance C as
- (v) When single line to earth fault occurs in solid grounding system, the phase to earth voltage of the remaining two healthy phases remain at

2. Pick up the correct words/figures from brackets and fill in the blanks.

- (i) The ungrounded neutral system cannot provide adequate protection against earth faults because the capacitive fault current is (*small, very large*)
- (ii) In Peterson coil grounding, when inductive fault current becomes equal to capacitive current of the system, then ($X_C = 3X_L$; $X_L = 3X_C$)
- (iii) In voltage transformer grounding of single phase transformer is connected between neutral and earth. (*secondary, primary*)
- (iv) In equipment grounding, the enclosure is connected to wire. (*ground, neutral*)
- (v) The ground wire is coloured (*black, green*)

- (vi) The neutral wire is coloured (black, green)
 (vii) In Peterson coil grounding, the inductance of the coil is (fixed, variable)
 (viii) In case of earth fault, the ungrounded neutral system lead to arcing ground. (does, does not)
 (ix) Grounding transformer is used where neutral available. (is, is not)
 (x) Most of the faults on an overhead system arefaults.(phase to earth, phase to phase)

ANSWERS TO SELF-TEST

- (i) line value (ii) $\sqrt{3}$ (iii) 3 (iv) $L = \frac{1}{3\omega^2 C}$ (v) normal phase voltage
- (i) small (ii) $X_C = 3X_L$ (iii) primary (iv) ground (v) green (vi) black (vii) variable (viii) does (ix) is not (x) phase to earth

CHAPTER REVIEW TOPICS

1. What do you mean by grounding or earthing? Explain it with an example.
2. Describe ungrounded or isolated neutral system. What are its disadvantages?
3. What do you mean by equipment grounding?
4. Illustrate the need of equipment grounding.
5. What is neutral grounding?
6. What are the advantages of neutral grounding?
7. What is solid grounding? What are its advantages?
8. What are the disadvantages of solid grounding?
9. What is resistance grounding? What are its advantages and disadvantages?
10. Describe Arc suppression coil grounding.
11. What is resonant grounding?

DISCUSSION QUESTIONS

1. Why is ground wire used in equipment grounding?
2. There is 11 kV/230V single phase transformer. One can notice that one of the secondary conductors is grounded. Why?
3. The H.V. line of a single phase transformer accidentally falls on L.V. line. There may be massive flash-over in a home or factory. Why?
4. In an overhead system, most of the faults are single line to ground. Why?
5. What are the factors causing arching grounds?
6. What is the importance of arc suppression coil grounding?
7. Where do we use grounding transformer?