

LETTERING

Lecture Week 3

Delivered By: Engr. Kiran Arshad

LETTERING

Writing text on a drawing (e.g. titles, dimensions, scales) using letters which can be alphabets, numerals, symbols or punctuation marks to convey detailed information.

Features of Lettering

- 1 Legibility, uniformity, ease, rapidity of execution reproducibility
2. No ornamental or artistic and cursive style of letter
3. Letters should be distinguishable from each other in order to avoid any confusion even in case of slight

Standard followed

IS 9609 (Part 0): 2001 & SP46: 2003 (lettering for technical drawings).
This BIS standard is based on ISO 3098-0: 1997

Types of Lettering

- **Single stroke** - Thickness of the line of the letter should be such as is obtained in one stroke of the pencil.
Does not mean that the letter should be made in one stroke without lifting the pencil.

- **Double stroke**- When more thickness is given to single stroke letters, it is known as double stroke or gothic letters.

- **BIS (SP46:2003)** - Gives dimensions for lettering & types

- **Type A** - Height of capital letter is divided into 14 parts
- **Type B** – Height of capital letter is divided into 10 parts

Both types can be Vertical or Inclined at 75° to the horizontal
Line Width of Type A < Type B

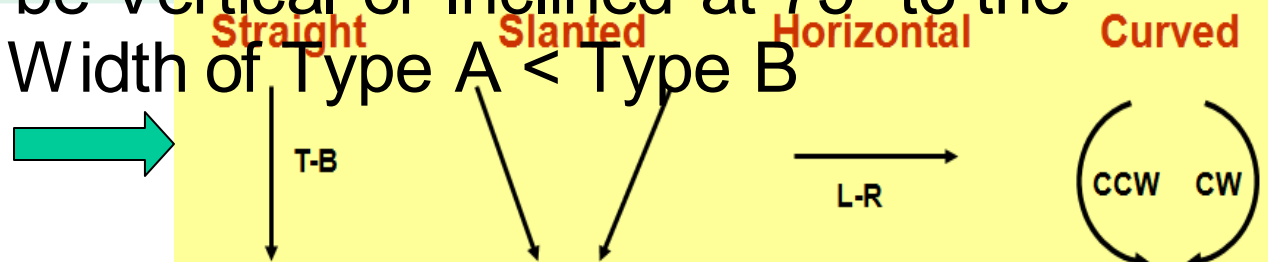

Basic Strokes

Examples of height and width of letters

BIS (SP 46: recommended heights of letters are 1.8, 2.5, 3.5, 5, 7, 10, 14 & 20 mm

2003) has letters the heights of as:

Sl. no	Items on a drawing	Size (mm)
1	Name of the company	10, 14, 20
2	Drawing numbers, letters denoting section planes	10, 14
3	Title of the drawing	7, 10
4	Sub- titles & Headings	5, 7
5	Dimensioning, notes, schedules & material lists	3.5, 7
6	Alteration entries and tolerances	3.5

Total height of lowercase letters equals that of capital letters

The height-to-width ratio for letters varies between 7 : 5 or 7 :

6



A & B type Lettering

BIS (SP46: 2003)

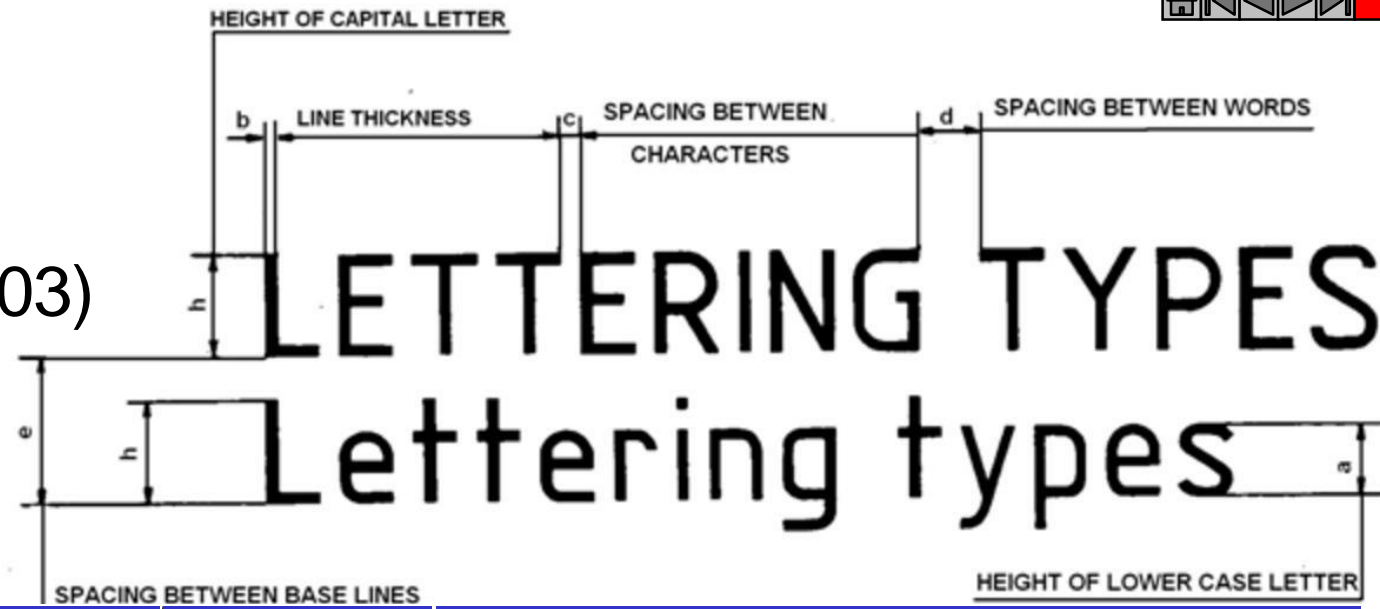

Specifications	Type	Value	Size (mm)						
			2.5	3.5	5	7	10	14	20
Capital letter height	A	h	2.5	3.5	5	7	10	14	20
	B	h	2.5	3.5	5	7	10	14	20
Lowercase letter height	A	$a=(5/7)h$	-	2.5	3.5	5	7	10	14
	B	$a=(7/10)h$	-	2.5	3.5	5	7	10	14
Thickness of lines	A	$b=(1/14)h$.18	.25	.35	.5	.7	1	1.4
	B	$b=(1/10)h$.25	.35	.5	.7	1	1.4	2
Spacing between characters	A	$c=(1/7)h$.35	.5	.7	1	1.4	2	2.8
	B	$c=(1/5)h$.5	.7	1	1.4	2	2.8	4
Minimum spacing between words	A	$d=(3/7)h$	1.05	1.5	2.1	3	4.2	6	8.4
	B	$d=(3/5)h$	1.5	2.1	3	4.2	6	8.4	12
Minimum spacing between baselines	A	$e=(10/7)h$	3.5	5	7	10	14	20	28
	B	$e=(7/5)h$	3.5	5	7	10	14	20	28



STRAIGHT-LINE LETTERS

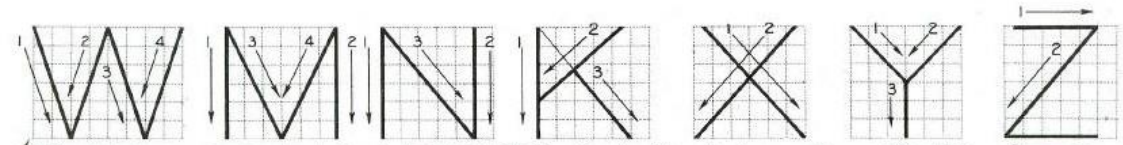
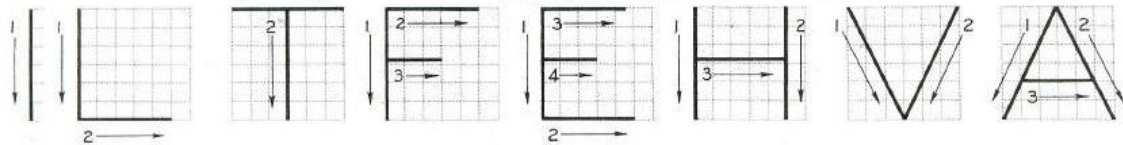

W is only letter over 6 units wide. Letters in "TOM Q. VAXY" are 6 units wide—all others are 5, except "I" and "W"

CURVED-LINE LETTERS

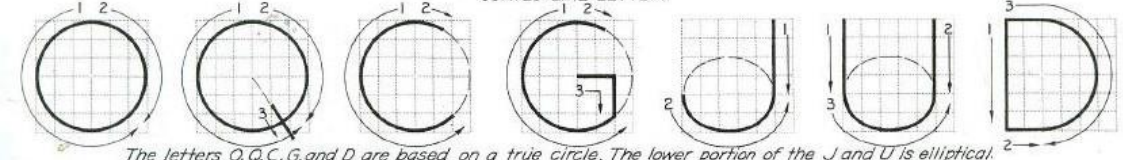

The letters O, Q, C, G, and D are based on a true circle. The lower portion of the J and U is elliptical.

CURVED-LINE LETTERS AND NUMERALS

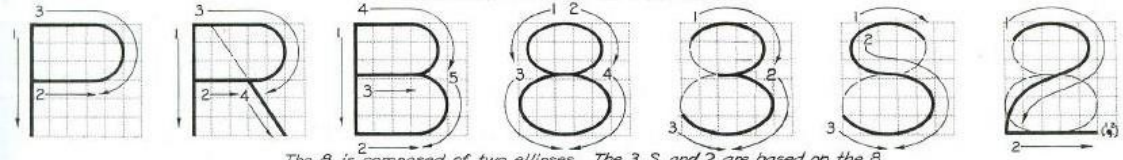

The B is composed of two ellipses. The 3, S, and 2 are based on the 8.

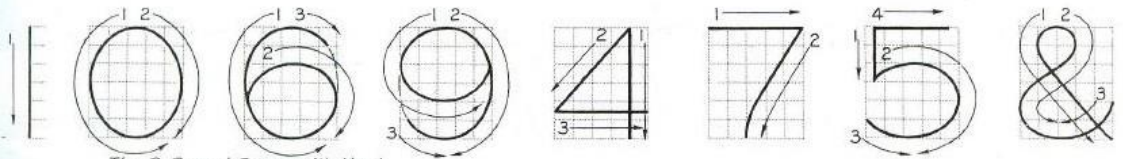

The O, 6, and 9 are elliptical.

Vertical Capital Letters and Numerical

Vertical Lowercase Letters

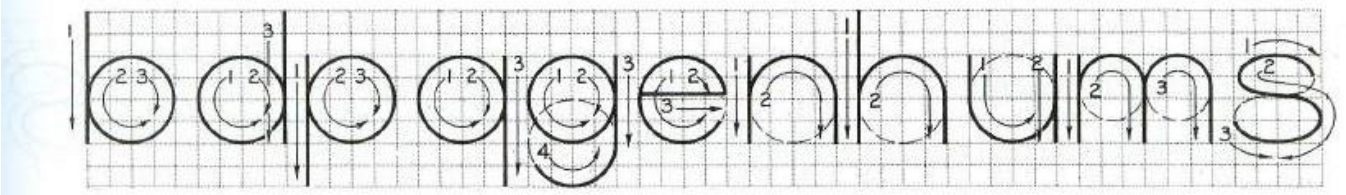
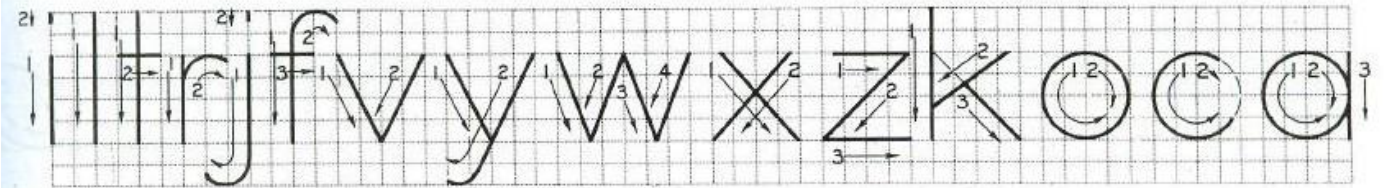

Fraction & Indices Lettering

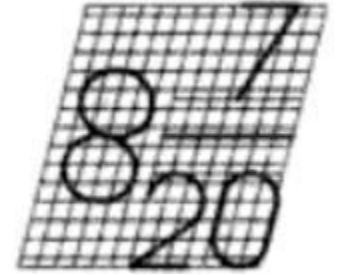
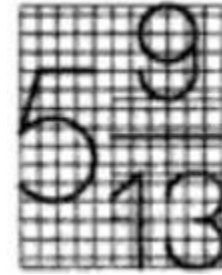

Inclined Capital Letters At 75°

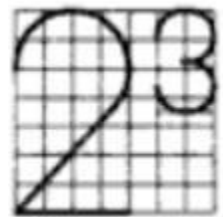

The height of index is half of height of a base

1. Height of numerator and denominator = $\frac{3}{4}$ th of height of non- fractioned number
2. Spacing between division bar and numerator or denominator should be such that the total height of fraction will be twice of that of non-fractioned number

Few Tips

If you put the central horizontal strokes of the letters B, E, F, and H at mid-height, they will appear to be below center. To overcome this optical illusion, draw the strokes B, E, F, and H slightly above the center as you letter, keeping letters uniform, as in the second example of fig(right below).

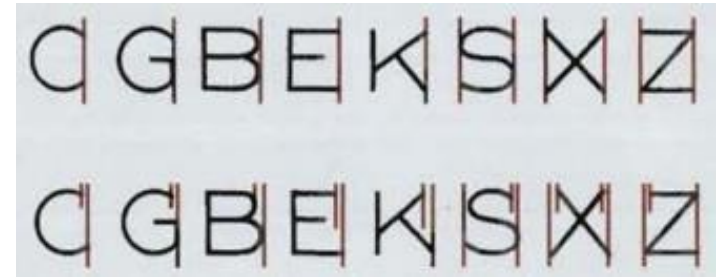
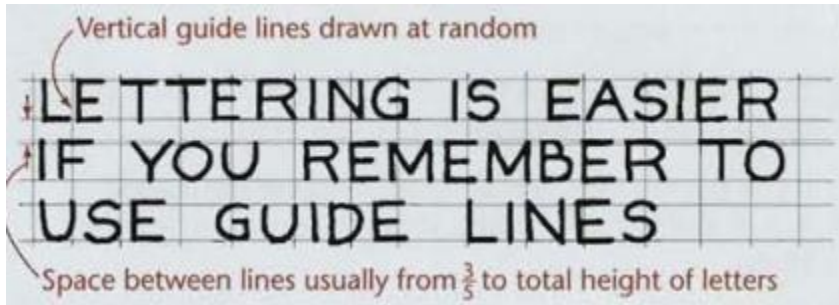

Use extremely light horizontal guidelines to keep letter height uniform as shown in Figure (left above). Do not use vertical guidelines to space the distance from one letter to the next within a word or sentence . This should be done by eye while lettering.

Some combinations, such as LT and VA, may have to be slightly closer than other letters to look correctly spaced. In some cases the width of a letter may be decreased slightly. In typesetting, pairs of letters that need to be spaced more closely to appear correctly are

called kerned pairs.

DIMENSIONING

BIS (SP 46: 2003) defines dimension as a numerical value expressed in appropriate units of measurement and indicated graphically on technical drawings with lines,

Features of Dimensioning

- 1 Units of measurement – length (mm), angles (degrees °)
- 2 Symbols – incorporated to indicate specific geometries
Notes – to give specification to particular feature or

Elements of Dimensioning

- Object lines
- Extension lines
- Dimension lines

- Leader lines
- Arrowheads
- Dimensions

Examples for elements of dimensioning

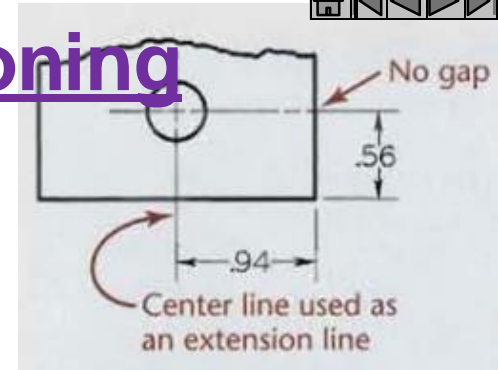
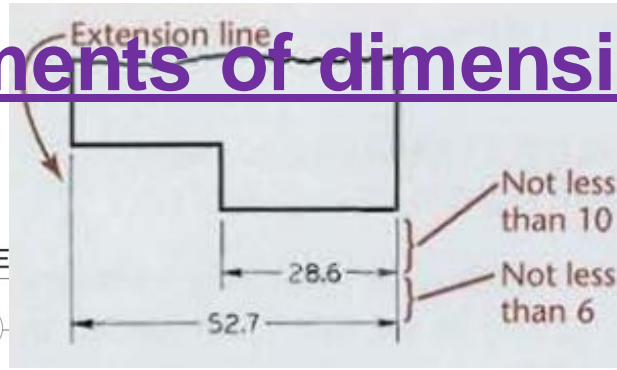
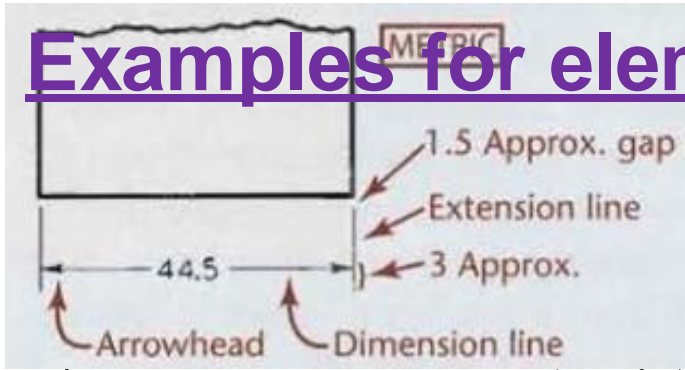

Elements of dimensioning

Definition

Object line

A line on the drawing whose length is to be shown is called an object line. In case of angles 2 lines forming angle will be object lines.

Extension line

An extension line is a thin continuous line drawn perpendicular to an object line. It extends by about 3 mm beyond the dimension line

Dimension line

Dimension line is drawn between 2 extension lines parallel to the object line. One dimension line represents one dimension. For angles a curved dimension line as arc with center at the vertex of angle is drawn. It is terminated by arrowheads touching the extension lines

Center line

A center-line is a thin, dark line alternating long and short dashes. Center-lines are commonly used as extension lines in locating holes and other symmetrical features. When extended for dimensioning. Center-lines cross over other lines of the drawing without gaps. Always end center-lines using a long dash.

Elements of dimensioning

Definition

Leader line

A leader or a pointer is a thin continuous line connecting a note or a dimension figure with the feature to which it applies. Never drawn vertical or horizontal but at some angle. A dot is used instead of an arrowhead if the leader ends inside the object.

Arrowheads

An arrowhead is placed at each end of a dimension line. Its pointed end touches an extension line. The size of an arrowhead should be proportional to the length of the dimension line. The length of the arrowhead should be about three times its maximum width.

Dimension

Placed near the middle and above the dimension lines or at the center of dimension lines by breaking them. As all dimensions of a drawing are in the same unit, instead of unit a note (ALL DIMENSIONS IN MM) preferable at the left hand side of title block is written. Dimension text should be uniform for all features.

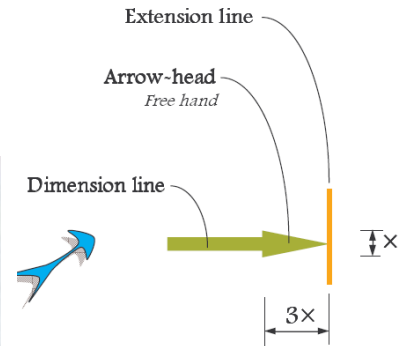
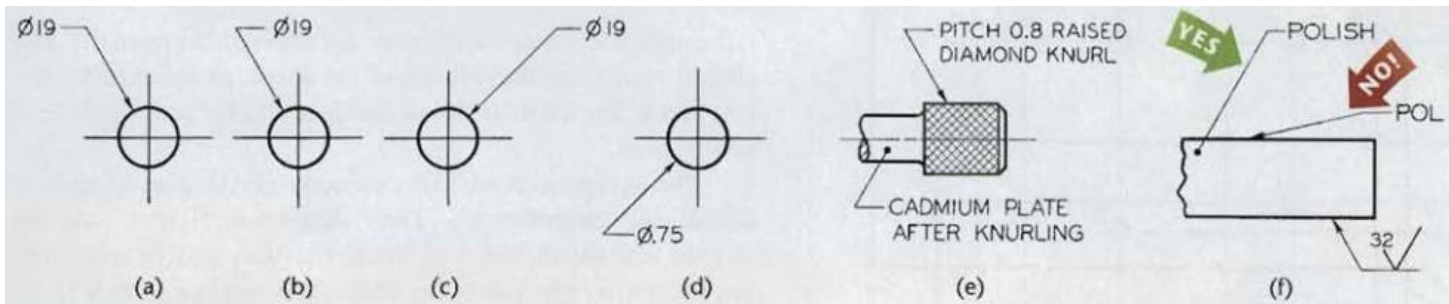

x = 3mm for usual drawings
 = 4-5mm for larger drawings

Best practices for dimension & extension lines

1. The shorter dimensions are nearest to the object outline.
2. Dimension lines should not cross extension lines as in Figure (b), which results from placing the shorter dimensions outside. Note that it is perfectly satisfactory to cross extension lines (Figure a), but they should not be shortened (Figure c).
3. Dimension lines should not cross each other & any other lines of the object. However extension lines can cross both (fig 1).
4. A dimension line should never coincide with or extend from any line of the drawing (Figure d).

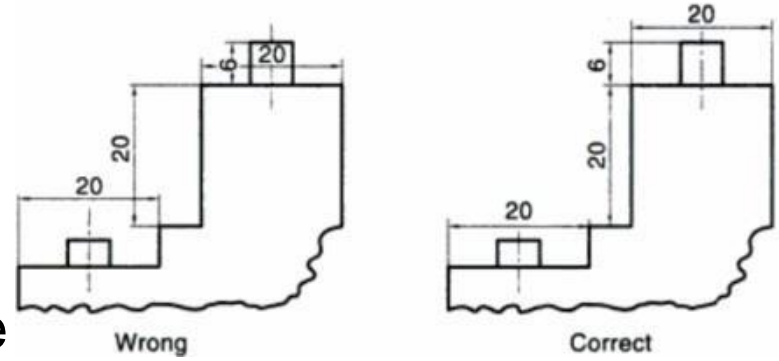
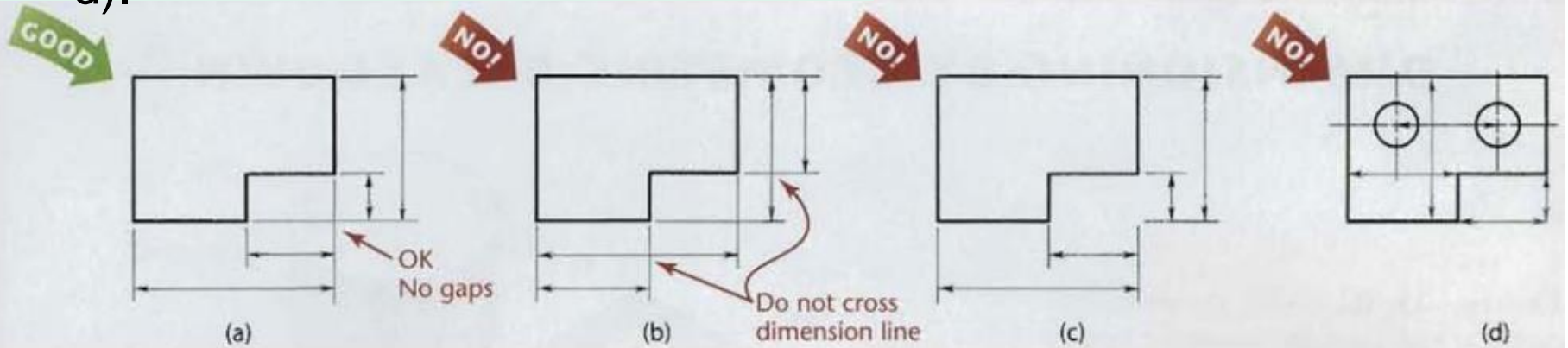

Fig 1



Best practices for dimension & extension lines

5 Dimensions should be lined up and grouped together as much as possible, as in Figure 2a, and not as in Figure 2b.

In some cases, extension lines and center-lines must

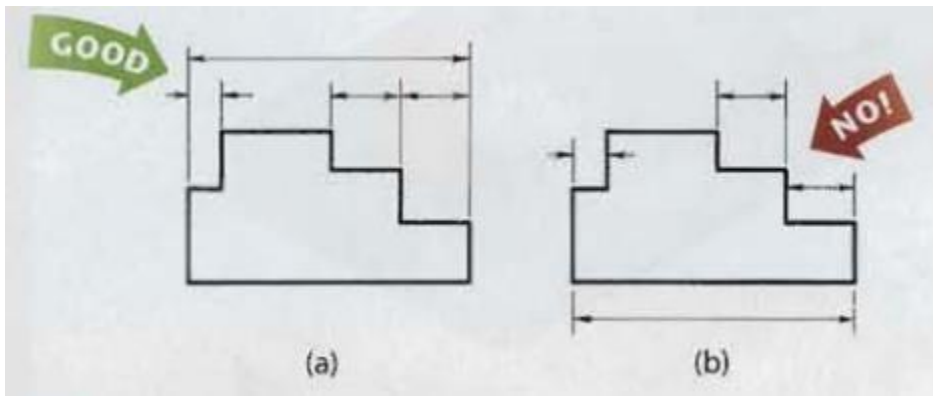

Fig 2

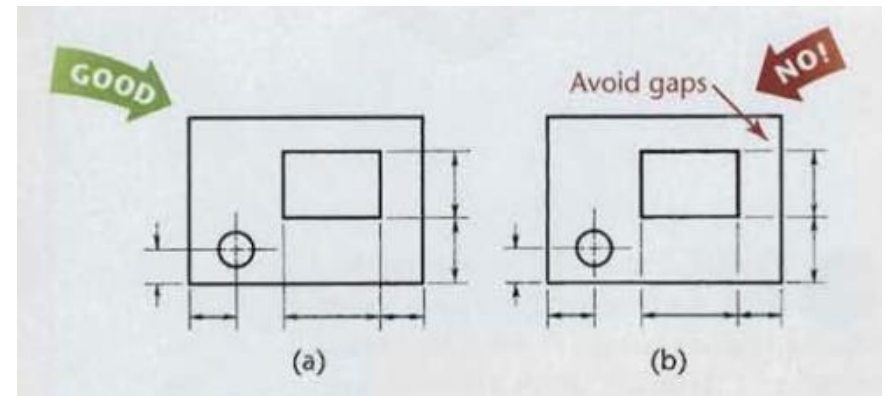
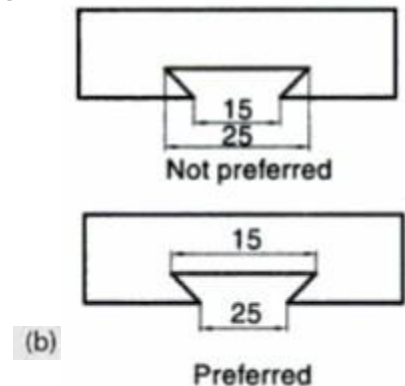
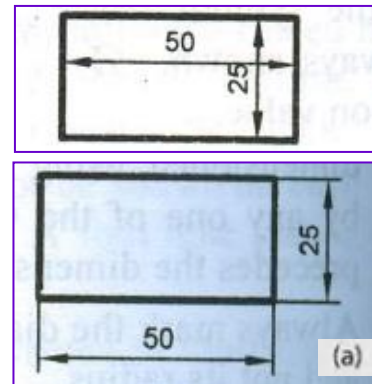

Fig 3

7 Dimension should be placed outside the view (a). Placed inside if clear and readable



Best practices for arrowheads & centerlines

- 1 Arrowheads should ordinarily be drawn within the limits of the dimensioned feature. But when the space is too

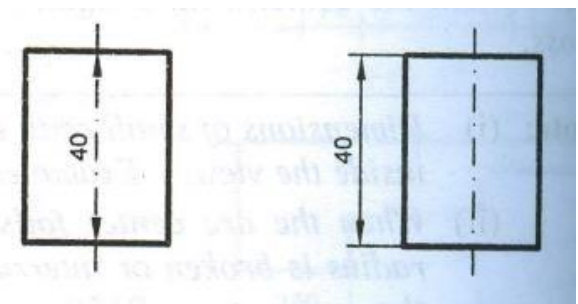
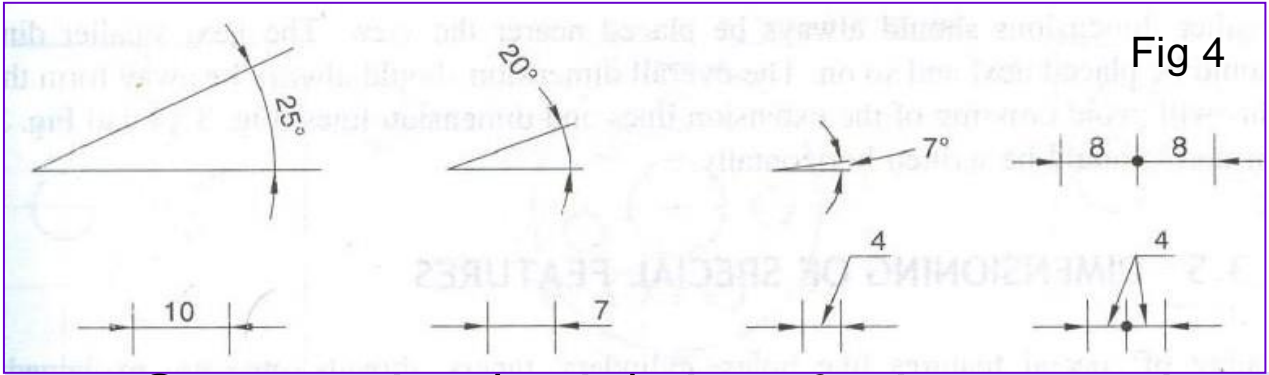

Fig 5a

1. Center line(axis) itself shall not be used as a dimension line with arrowheads as its ends. Fig 5a
2. Center line(axis) itself shall not be used as a dimension line with arrowheads as its ends. Fig 5b

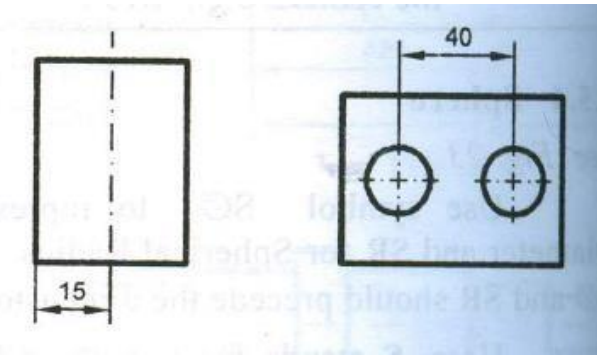

Fig 5b

3. Center-lines should not extend from view to view.

Best practices for dimensions

- 1 All dimensions must be given. There should not be need for assumption or direct measurement for any dimension.
2. Each dimension should be given only once. No dimension should be redundant / superfluous (repeated) (fig 6). Not even on another

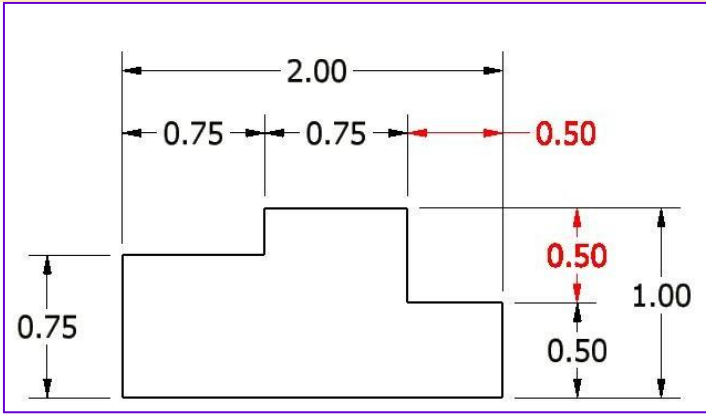

Fig 6

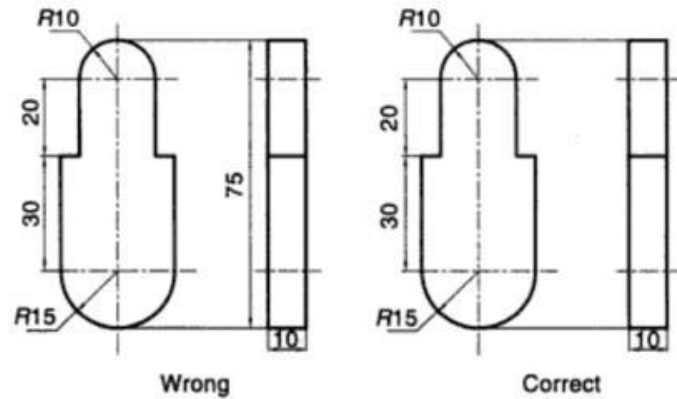
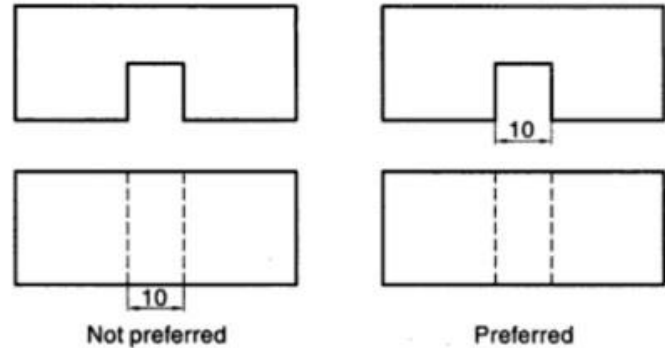

Fig 7

3. Dimensions shall be given to visible lines and not to hidden lines
4. Each feature is dimensioned and positioned where its shape shows.



Best practices for dimensioning pictorial view

- 1 Principal lines are dimensioned in pictorial view. Dimension and extension lines are drawn in directions that are parallel to the principal lines. For non-principal lines, its

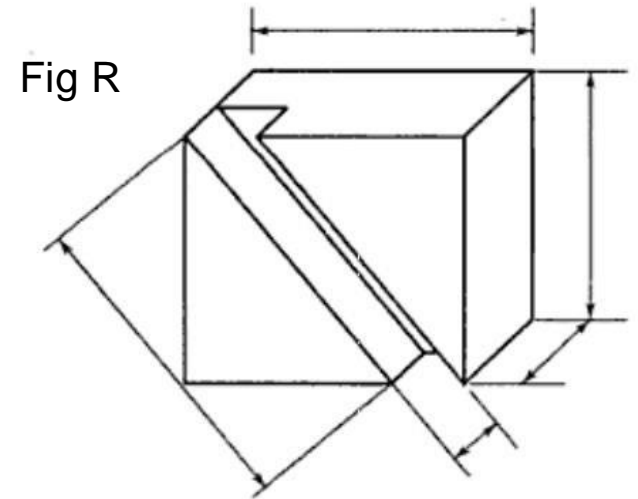
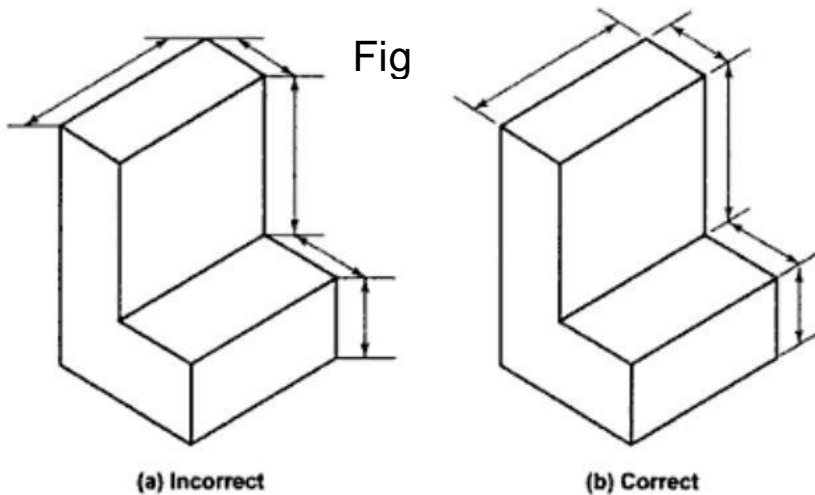

- 2 In case of oblique parallel projections, along with principal lines, those lines which are projected with true length are also dimensioned. In those cases, extension lines

Systems of dimensioning

For placing the dimensions on the drawing, following systems can be adopted.

Aligned system

1. Dimensions are placed perpendicular to the dimension line.
2. Horizontal and inclined dimensions can be read from the bottom of the drawing. Vertical dimensions can be read from the right-hand side of the drawing.
3. All dimensions are placed above the midpoint of dimension lines.

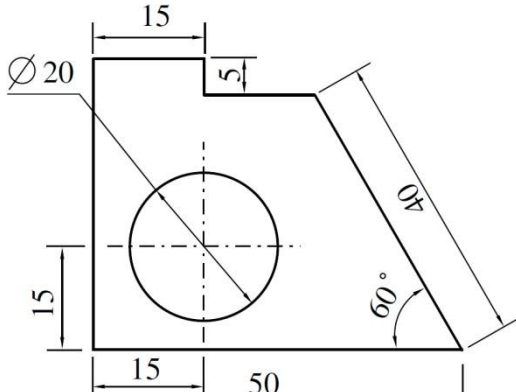

Unidirectional system

1. Dimensions are placed vertically irrespective of dimension lines.
2. All dimensions can be read from the bottom of the drawing.
3. Horizontal dimensions are placed above the midpoint of dimension lines. Vertical and inclined dimensions are placed at the middle of dimension lines by breaking them.

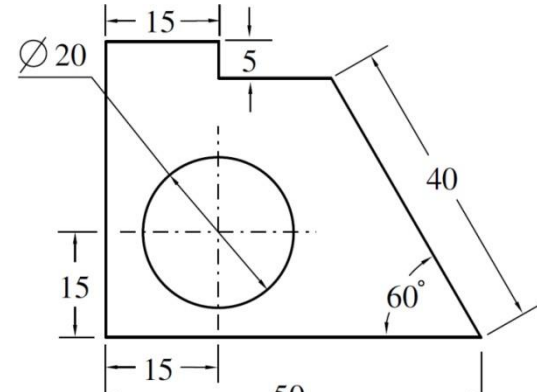

Note

All the dimensions on a drawing must be shown using either Aligned System or Unidirectional System. Two systems should not be mixed on the same

References

- **Dr. Poonam Kumari, ED-ME111,
L-2**