

CHAPTER

16



Introduction to Switchgear

- 16.1 Switchgear
- 16.2 Essential Features of Switchgear
- 16.3 Switchgear Equipment
- 16.4 Bus-Bar Arrangements
- 16.5 Switchgear Accommodation
- 16.6 Short-Circuit
- 16.7 Short-Circuit Currents
- 16.8 Faults in a Power System

General

A great demand for electrical energy is a notable feature of modern civilisation. Most of this energy is needed for lighting, heating, domestic appliances, industrial electrical machinery and electric traction. The importance of electric supply in everyday life has reached such a stage that it is desirable to protect the power system from harm during fault conditions and to ensure maximum continuity of supply. For this purpose, means must be provided to switch on or off generators, transmission lines, distributors and other equipment under both normal and abnormal conditions. This is achieved by an apparatus called *switchgear*. A switchgear essentially consists of switching and protecting devices such as switches, fuses, circuit breakers, relays *etc.*

During normal operation, switchgear permits to switch on or off generators, transmission lines, distributors and other electrical equipment. On the other hand, when a failure (*e.g.* short circuit) occurs on any part of power system, a heavy current flows through the equipment, threatening damage to the equipment and interruption of service to the customers. However, the switchgear detects the fault and disconnects the unhealthy

section from the system. In this way, switchgear protects the system from the damage and ensures continuity of supply. In this chapter, we shall present the elementary introduction to switchgear.

16.1 Switchgear

*The apparatus used for switching, controlling and protecting the electrical circuits and equipment is known as **switchgear**.*

The switchgear equipment is essentially concerned with switching and interrupting currents either under normal or abnormal operating conditions. The tumbler switch with ordinary fuse is the simplest form of switchgear and is used to control and protect lights and other equipment in homes, offices *etc.* For circuits of higher rating, a high-rupturing capacity (H.R.C.) fuse in conjunction with a switch may serve the purpose of controlling and protecting the circuit. However, such a switchgear cannot be used profitably on high voltage system (3.3 kV) for two reasons. Firstly, when a fuse blows, it takes sometime to replace it and consequently there is interruption of service to the customers. Secondly, the fuse cannot successfully interrupt large fault currents that result from the faults on high voltage system.

With the advancement of power system, lines and other equipments operate at high voltages and carry large currents. When a short circuit occurs on the system, heavy current flowing through the equipment may cause considerable damage. In order to interrupt such heavy fault currents, *automatic circuit breakers* (or simply circuit breakers) are used. A circuit breaker is a switchgear which can open or close an electrical circuit under both normal and abnormal conditions. Even in instances where a fuse is adequate, as regards to breaking capacity, a circuit breaker may be preferable. It is because a circuit breaker can close circuits, as well as break them without replacement and thus has wider range of use altogether than a fuse.

16.2 Essential Features of Switchgear

The essential features of switchgear are :

(i) Complete reliability. With the continued trend of interconnection and the increasing capacity of generating stations, the need for a reliable switchgear has become of paramount importance. This is not surprising because switchgear is added to the power system to improve the reliability. When fault occurs on any part of the power system, the switchgear must operate to isolate the faulty section from the remainder circuit.

(ii) Absolutely certain discrimination. When fault occurs on any section of the power system, the switchgear must be able to discriminate between the faulty section and the healthy section. It should isolate the faulty section from the system without affecting the healthy section. This will ensure continuity of supply.

(iii) Quick operation. When fault occurs on any part of the power system, the switchgear must operate quickly so that no damage is done to generators, transformers and other equipment by the short-circuit currents. If fault is not cleared by switchgear quickly, it is likely to spread into healthy parts, thus endangering complete shut down of the system.

(iv) Provision for manual control. A switchgear must have provision for manual control. In case the electrical (or electronics) control fails, the necessary operation can be carried out through manual control.

(v) Provision for instruments. There must be provision for instruments which may be required. These may be in the form of ammeter or voltmeter on the unit itself or the necessary current and voltage transformers for connecting to the main switchboard or a separate instrument panel.

16.3 Switchgear Equipment

Switchgear covers a wide range of equipment concerned with switching and interrupting currents

under both normal and abnormal conditions. It includes switches, fuses, circuit breakers, relays and other equipment. A brief account of these devices is given below. However, the reader may find the detailed discussion on them in the subsequent chapters.

1. Switches. A switch is a device which is used to open or close an electrical circuit in a convenient way. It can be used under full-load or no-load conditions *but* it cannot interrupt the fault currents. When the contacts of a switch are opened, an *arc is produced in the air between the contacts. This is particularly true for circuits of high voltage and large current capacity. The switches may be classified into (i) air switches (ii) oil switches. The contacts of the former are opened in air and that of the latter are opened in oil.

(i) **Air-break switch.** It is an air switch and is designed to open a circuit *under load*. In order to quench the arc that occurs on opening such a switch, special arcing horns are provided. Arcing horns are pieces of metals between which arc is formed during opening operation. As the switch opens, these horns are spread farther and farther apart. Consequently, the arc is lengthened, cooled and interrupted. Air-break switches are generally used outdoor for circuits of medium capacity such as lines supplying an industrial load from a main transmission line or feeder.

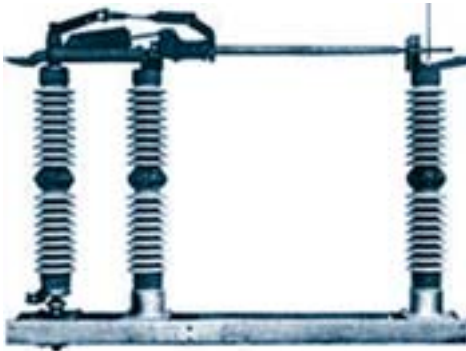

Air - break Switch



Isolator Switch

(ii) **Isolator or disconnecting switch.** It is essentially a knife switch and is designed to open a circuit under *no load*. Its main purpose is to isolate one portion of the circuit from the other and is not intended to be opened while current is flowing in the line. Such switches are generally used on both sides of circuit breakers in order that repairs and replacement of circuit breakers can be made without any danger. They should never be opened until the circuit breaker in the same circuit has been opened and should always be closed before the circuit breaker is closed.

(iii) **Oil switches.** As the name implies, the contacts of such switches are opened under oil, usually transformer oil. The effect of oil is to cool and quench the arc that tends to form when the circuit is opened. These switches are used for circuits of high voltage and large current carrying capacities.

2. Fuses. A fuse is a short piece of wire or thin strip which melts when excessive current flows through it for sufficient time. It is inserted in series with the circuit to be protected. Under normal operating conditions, the fuse element is at a temperature below its melting point. Therefore, it carries the normal load current without overheating. However, when a short circuit or overload occurs, the current through the fuse element increases beyond its rated capacity. This raises the temperature and the fuse element melts (or blows out), disconnecting the circuit protected by it. In

* Generally, the load contains reactive elements (inductance and capacitance). The sudden change of current in the circuit due to breaking results in the production of large induced e.m.f. (several thousand volts) which ruptures the insulation of air inbetween the contacts, causing a spark.

this way, a fuse protects the machines and equipment from damage due to excessive currents. It is worthwhile to note that a fuse performs both detection and interruption functions.

3. Circuit breakers. A circuit breaker is an equipment which can open or close a circuit under all conditions *viz.* no load, full load and fault conditions. It is so designed that it can be operated manually (or by remote control) under normal conditions and automatically under fault conditions. For the latter operation, a relay circuit is used with a circuit breaker. Fig. 16.1 (i) shows the parts of a typical oil circuit breaker whereas Fig. 16.1 (ii) shows its control by a relay circuit. The circuit breaker essentially consists of moving and fixed contacts enclosed in strong metal tank and immersed in oil, known as transformer oil.

Under normal operating conditions, the contacts remain closed and the circuit breaker carries the full-load current continuously. In this condition, the e.m.f. in the secondary winding of current transformer (C.T.) is insufficient to operate the trip coil of the breaker but the contacts can be opened (and hence the circuit can be opened) by manual or remote control. When a fault occurs, the resulting overcurrent in the C.T. primary winding increases the secondary e.m.f. This energises the trip coil of the breaker and moving contacts are pulled down, thus opening the contacts and hence the circuit. The arc produced during the opening operation is quenched by the oil. It is interesting to note that relay performs the function of detecting a fault whereas the circuit breaker does the actual circuit interruption.

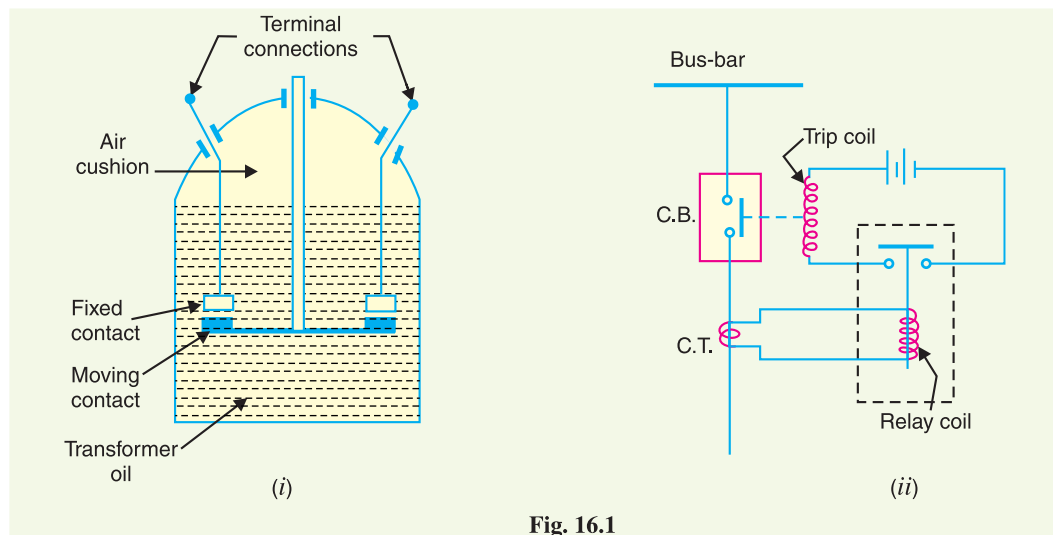

Fig. 16.1

4. Relays. A relay is a device which detects the fault and supplies information to the breaker for circuit interruption. Fig. 16.1 (ii) shows a typical relay circuit. It can be divided into three parts *viz.*

- (i) The primary winding of a *current transformer (C.T.) which is connected in series with the circuit to be protected. The primary winding often consists of the main conductor itself.
- (ii) The second circuit is the secondary winding of C.T. connected to the relay operating coil.
- (iii) The third circuit is the tripping circuit which consists of a source of supply, trip coil of circuit breaker and the relay stationary contacts.

Under normal load conditions, the e.m.f. of the secondary winding of C.T. is small and the current flowing in the relay operating coil is insufficient to close the relay contacts. This keeps the trip coil of the circuit breaker unenergised. Consequently, the contacts of the circuit breaker remain closed and it carries the normal load current. When a fault occurs, a large current flows through the

* The circuit to be protected carries a large current (normal or fault current) and is reduced to a suitable value for relay operation with the help of a current transformer.

primary of C.T. This increases the secondary e.m.f. and hence the current through the relay operating coil. The relay contacts are closed and the trip coil of the circuit breaker is energised to open the contacts of the circuit breaker.

16.4 Bus-Bar Arrangements

When a number of generators or feeders operating at the same voltage have to be directly connected electrically, bus-bars are used as the common electrical component. *Bus-bars are copper rods or thin walled tubes and operate at constant voltage. We shall discuss some important bus-bars arrangements used for power stations and sub-stations. All the diagrams refer to 3-phase arrangement but are shown in single-phase for simplicity.

(1) Single Bus-bar System. The single bus-bar system has the simplest design and is used for power stations. It is also used in small outdoor stations having relatively few outgoing or incoming feeders and lines. Fig. 16.2 shows the single bus-bar system for a typical power station. The generators, outgoing lines and transformers are connected to the bus-bar. Each generator and feeder is controlled by a circuit breaker. The isolators permit to isolate generators, feeders and circuit breakers from the bus-bar for maintenance. The chief advantages of this type of arrangement are low initial cost, less maintenance and simple operation.

Disadvantages. Single bus-bar system has the following three principal disadvantages :

- (i) The bus-bar cannot be cleaned, repaired or tested without de-energising the whole system.
- (ii) If a fault occurs on the bus-bar itself, there is complete interruption of supply.
- (iii) Any fault on the system is fed by all the generating capacity, resulting in very large fault currents.

(2) Single bus-bar system with Sectionalisation. In large generating stations where several units are installed, it is a common practice to sectionalise the bus so that fault on any section of the bus-bar will not cause complete shut down. This is illustrated in Fig. 16.3 which shows the bus-bar divided into two sections connected by a circuit breaker and isolators. Three principal advantages are claimed for this arrangement. Firstly, if a fault occurs on any section of the bus-bar, that section can be isolated without affecting the supply to other sections. Secondly, if a fault occurs on any feeder, the fault current is much **lower than with unsectionalised bus-bar. This permits the use of circuit breakers of lower capacity in the feeders. Thirdly, repairs and maintenance of any section of the bus-bar can be carried out by de-energising that section only, eliminating the possibility of complete shut-down.

It is worthwhile to keep in mind that a circuit breaker should be used as the sectionalising switch so that uncoupling of the bus-bars may be carried out safely during load transfer. Moreover, the circuit breaker itself should be provided with isolators on both sides so that its maintenance can be done while the bus-bars are alive.

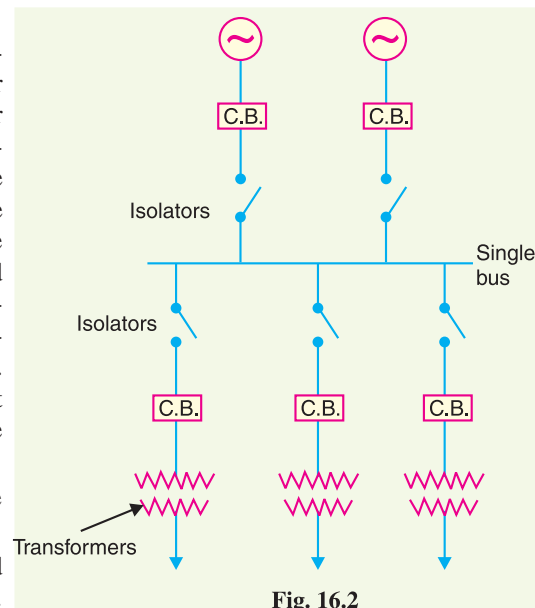

Fig. 16.2

* The term bus is derived from the word omnibus, meaning collector of things. Thus, electrical bus-bar is the collector of electrical energy at one location.

** because a feeder fault is fed from one section only.

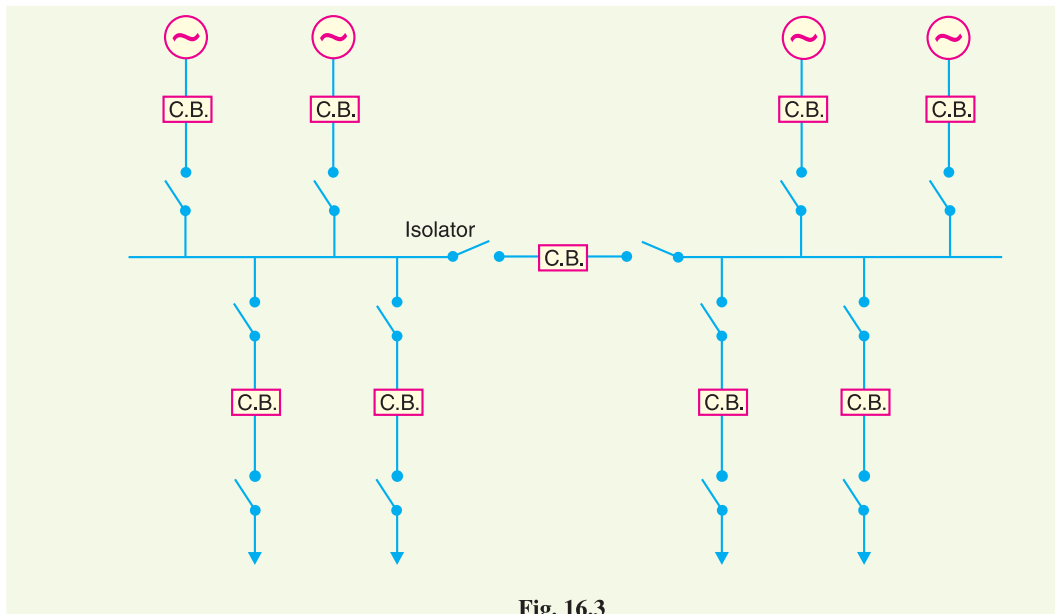

Fig. 16.3

(3) **Duplicate bus-bar system.** In large stations, it is important that breakdowns and maintenance should interfere as little as possible with continuity of supply. In order to achieve this objective, duplicate bus-bar system is used in important stations. Such a system consists of two bus-bars, a “main bus-bar” and a “spare” bus-bar (see Fig. 16.4). Each generator and feeder may be connected to either bus-bar with the help of bus coupler which consists of a circuit breaker and isolators.

In the scheme shown in Fig. 16.4, service is interrupted during switch over from one bus to another. However, if it were desired to switch a circuit from one to another without interruption of service, there would have to be two circuit breakers per circuit. Such an arrangement will be too expensive.

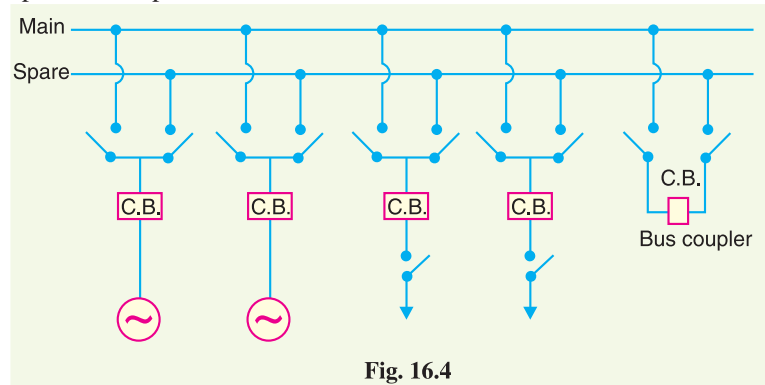

Fig. 16.4

Advantages

- (i) If repair and maintenance is to be carried on the main bus, the supply need not be interrupted as the entire load can be transferred to the spare bus.
- (ii) The testing of feeder circuit breakers can be done by putting them on spare bus-bar, thus keeping the main bus-bar undisturbed.
- (iii) If a fault occurs on the bus-bar, the continuity of supply to the circuit can be maintained by transferring it to the other bus-bar.

16.5 Switchgear Accommodation

The main components of a switchgear are circuit breakers, switches, bus-bars, instruments and instrument transformers. It is necessary to house the switchgear in power stations and sub-stations in such a way so as to safeguard personnel during operation and maintenance and to ensure that the effects of

fault on any section of the gear are confined to a limited region. Depending upon the voltage to be handled, switchgear may be broadly classified into (i) outdoor type (ii) indoor type.

(i) *Outdoor type.* For voltages beyond 66 kV, switchgear equipment is installed outdoor. It is because for such voltages, the clearances between conductors and the space required for switches, circuit breakers, transformers and others equipment become so great that it is not economical to install all such equipment indoor.

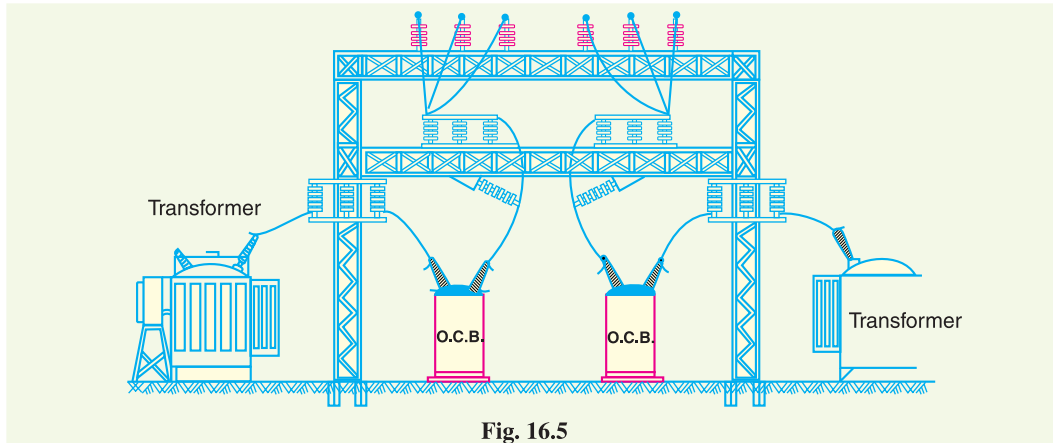

Fig. 16.5

Fig. 16.5 shows a typical outdoor sub-station with switchgear equipment. The circuit breakers, isolators, transformers and bus-bars occupy considerable space on account of large electrical clearance associated with high voltages.

(ii) *Indoor type.* For voltages below 66 kV, switchgear is generally installed indoor because of economic considerations. The indoor switchgear is generally of metal-clad type. In this type of construction, all live parts are completely enclosed in an earthed metal casing. The primary object of this practice is the definite localisation and restriction of any fault to its place of origin.

16.6 Short-Circuit

Whenever a fault occurs on a network such that a large current flows in one or more phases, a **short-circuit** is said to have occurred.

When a short circuit occurs, a heavy current called short circuit current flows through the circuit. This can be beautifully illustrated by referring to Fig. 16.6 where a single phase generator of voltage V and internal impedance Z_i is supplying to a load Z . Under normal conditions, the current in the circuit is limited by *load impedance Z . However, if the load terminals get shorted due to any reason, the circuit impedance is reduced to a very low value ; being Z_i in this case. As Z_i is very small, therefore, a large current flows through the circuit. This is called short-circuit current. It is worthwhile to make a distinction between a ****short-circuit** and an **overload**. When a short-circuit occurs, the voltage at fault point is reduced to zero and current of abnormally high magnitude flows through the network to the point of fault. On the other hand, an overload means that loads greater than the designed values have been imposed on the system. Under such conditions, the voltage at the overload point may be low, but not zero. The undervoltage conditions may extend for some distance beyond the overload point into the remainder of the system. The currents in the overloaded

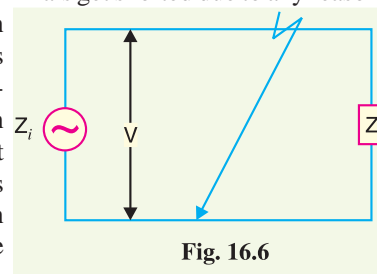

Fig. 16.6

* As internal impedance Z_i of the generator is generally small.

** Note that path of current is shortened and hence the name short circuit current.

equipment are high but are substantially lower than that in the case of a short-circuit.

Causes of short-circuit. A short circuit in the power system is the result of some kind of abnormal conditions in the system. It may be caused due to internal and/or external effects.

(i) **Internal effects** are caused by breakdown of equipment or transmission lines, from deterioration of insulation in a generator, transformer *etc.* Such troubles may be due to ageing of insulation, inadequate design or improper installation.

(ii) **External effects** causing short circuit include insulation failure due to lightning surges, overloading of equipment causing excessive heating; mechanical damage by public *etc.*

Effects of short-circuit. When a short-circuit occurs, the current in the system increases to an abnormally high value while the system voltage decreases to a low value.

(i) The heavy current due to short-circuit causes excessive heating which may result in fire or explosion. Sometimes short-circuit takes the form of an arc and causes considerable damage to the system. For example, an arc on a transmission line not cleared quickly will burn the conductor severely causing it to break, resulting in a long time interruption of the line.

(ii) The low voltage created by the fault has a very harmful effect on the service rendered by the power system. If the voltage remains low for even a few seconds, the consumers' motors may be shut down and generators on the power system may become unstable.

Due to above detrimental effects of short-circuit, it is desirable and necessary to disconnect the faulty section and restore normal voltage and current conditions as quickly as possible.

16.7 Short-Circuit Currents

Most of the failures on the power system lead to short-circuit fault and cause heavy current to flow in the system. The calculations of these short-circuit currents are important for the following reasons :

- (i) A short-circuit on the power system is cleared by a circuit breaker or a fuse. It is necessary, therefore, to know the maximum possible values of short-circuit current so that switchgear of suitable rating may be installed to interrupt them.
- (ii) The magnitude of short-circuit current determines the setting and sometimes the types and location of protective system.
- (iii) The magnitude of short-circuit current determines the size of the protective reactors which must be inserted in the system so that the circuit breaker is able to withstand the fault current.
- (iv) The calculation of short-circuit currents enables us to make proper selection of the associated apparatus (*e.g.* bus-bars, current transformers *etc.*) so that they can withstand the forces that arise due to the occurrence of short circuits.

16.8 Faults in a Power System

A fault occurs when two or more conductors that normally operate with a potential difference come in contact with each other. These faults may be caused by sudden failure of a piece of equipment, accidental damage or short-circuit to overhead lines or by insulation failure resulting from lightning surges. Irrespective of the causes, the faults in a 3-phase system can be classified into two main categories *viz.*

(i) Symmetrical faults (ii) Unsymmetrical faults

(i) **Symmetrical faults.** That fault which gives rise to symmetrical fault currents (*i.e.* equal faults currents with 120° displacement) is called a symmetrical fault. The most common example of symmetrical fault is when all the three conductors of a 3-phase line are brought together simultaneously into a short-circuit condition. The method of calculating fault currents for symmetrical faults is discussed in chapter 17.

(ii) **Unsymmetrical faults.** Those faults which give rise to unsymmetrical currents (*i.e.* unequal line currents with unequal displacement) are called unsymmetrical faults. The unsymmetrical faults may take one of the following forms :

(a) Single line-to-ground fault (b) Line-to-line fault (c) Double line-to-ground fault

The great majority of faults on the power system are of unsymmetrical nature; the most common type being a short-circuit from one line to ground. The calculations of such fault currents are made by “symmetrical components” method. This is fully discussed in chapter 18.

SELF - TEST

1. Fill in the blanks by inserting appropriate words/figures.

- (i) A fuse is a device.
- (ii) A circuit breaker is a device.
- (iii) An isolator is designed to open a circuit under
- (iv) When a switch is opened, is produced.
- (v) Under normal operating conditions, the contacts of the circuit breaker remain
- (vi) Under fault conditions, supplies information to the circuit breaker to open.
- (vii) If a fault occurs on the bus itself in a single bus-bar system, then there is complete
- (viii) The sectionalised bus-bar system gives fault current than that of unsectionalised bus-bar.
- (ix) For greater flexibility, bus-bar system is used.
- (x) The outdoor type switchgear is generally used for voltages beyond kV.

2. Pick up the correct words/figures from brackets and fill in the blanks.

- (i) A fuse performs functions. (both detection and interruption, interruption)
- (ii) The circuit breaker performs function. (detection, circuit interruption)
- (iii) For voltages beyond 66 kV, switchgear equipment is installed (indoor, outdoor)
- (iv) Bus-bars operate at voltage. (constant, variable)
- (v) Isolator is an switch. (air, oil)

ANSWERS TO SELF-TEST

1. (i) protective (ii) circuit interrupting (iii) no load (iv) arc (v) closed (vi) relay (vii) shut down (viii) lower (ix) duplicate (x) 66
2. (i) both detection and interruption (ii) circuit interruption (iii) outdoor (iv) constant (v) air

CHAPTER REVIEW TOPICS

1. What do you understand by switchgear ?
2. Discuss the various types of switches.
3. What is the difference between
 - (i) a switch and circuit breaker
 - (ii) a fuse and circuit breaker ?
4. Discuss the different types of bus-bar arrangements.
5. Explain the various methods of accommodating high-voltage switchgear.

DISCUSSION QUESTIONS

1. What are the limitations of a fuse ?
2. Why do we use C.T. in the relay circuit ?
3. What is the necessity of bus-bar ?
4. Why do we use isolators on both sides of the circuit breaker ?
5. Why are isolators not opened on load ?
6. Which faults ___ symmetrical or unsymmetrical ___ are more frequent in power system and why ?
7. Suddenly a circuit carries a current 20 times the normal current. Is there possibility of short-circuit or overload ?