

## CEMENT

Cement is a bonding agent used to bind various construction materials like brick, stones, concrete blocks, etc.

- Cement is used in the form of mortar (cement + sand + water) in certain specific ratios or in the form of concrete (cement + sand + crush + water) in certain specific ratio.
- Cements have been known and used for at least two thousand years. The cements used by the Romans were natural and pozzolan cements, made from naturally occurring mixtures of limestone and clay and from a mixture of slaked lime and volcanic ash containing silica.

- **Portland Cement**

Its quick setting property, strength and ease with which it can be used under variety of conditions has revolutionized the concept of construction and made it the most popular cementing material.

In 1824, first step was made in producing the type of cement with which we are familiar today. The inventor, Joseph Aspdin, produced a powder made from the calcined mixture of limestone and clay. He called it Portland cement, because when it hardened it produced a material resembling stone from the quarries near Portland, in England.

Modern Portland cement is made from materials which contain the proper proportions of lime, silica, alumina and iron with minor amounts of magnesia and sulfur trioxide.

Table below indicates the range of oxide composition usually used in normal Portland cements.

### **Oxide composition of Type 1 (ASTM Type 1) or Normal Portland Cement**

Calcium Oxide (CaO), Lime	60 to 66 %
Silica (SiO <sub>2</sub> )	19 to 25 %
Aluminum Oxide (Al <sub>2</sub> O <sub>3</sub> ), Alumina	03 to 08 %
Ferrous Oxide (Fe <sub>2</sub> O <sub>3</sub> ), Iron	01 to 0 5 %
Magnesium Oxide (MgO), Magnesia	0 0 to 0 5 %
Sulfur Trioxide (SO <sub>3</sub> )	01 to 0 3 %
Alkalies	01 %

**Functions of Ingredients:**

1. **Lime:** Lime is the important ingredient of cement and its proportion is to be maintained carefully. Lime in excess makes the cement unsound and causes the cement to expand and disintegrate. On the other hand, if lime is in deficiency the strength of the cement is decreased and it causes cement to set quickly
2. **Silica:** This also an important ingredient of cement and it gives or imparts quick setting property to cement.
3. **Alumina:** This ingredient imparts quick setting properly to cement. Excess of alumina weakens the cement.
4. **Calcium Sulphate:** This ingredient is in the form of gypsum and its function is to increase the initial setting time of cement.
5. **Magnesia:** The small amount of this ingredient imparts hardness and color to cement. Portland cement is hydraulic cement. That is, it reacts with water (hydrates) to produce a substance that is durable, resists the effects of water and continues to gain strength as long as moisture is present. It will continue to gain strength even when completely submerged in water. Compared to hydraulic limes, the strength gain is quite rapid and much greater in value.
6. **Sulphur:** A very small amount of sulphur is useful in making sound cement. If it is in excess, it causes the cement to become unsound.
7. **Alkalies:** Most of the alkalies present in raw material are carried away by the flue gases during heating and only small quantity will be left. If they are in excess in cement, efflorescence is caused.

All the above compounds undergo some chemical combinations during the process of burning and fusion. Main constituents of Cement are

1. Tricalcium silicate,  $3\text{CaO} \cdot \text{SiO}_2$  ( $\text{C}_3\text{S}$ )
2. Dicalcium silicate,  $2\text{CaO} \cdot \text{SiO}_2$  ( $\text{C}_2\text{S}$ )
3. Tricalcium aluminate,  $3\text{CaO} \cdot \text{Al}_2\text{O}_3$  ( $\text{C}_3\text{A}$ )
4. Tetracalcium aluminoferrite,  $4\text{CaO} \cdot \text{Al}_2\text{O}_3 \cdot \text{Fe}_2\text{O}_3$  ( $\text{C}_4\text{AF}$ )

**Tri-Calcium Silicate** is the best cementing material and the more it is present in cement the better the cement is. In a properly burnt clinker Tri-Calcium Silicate should be about 40%. In case the burning is not done properly then the clinker shall have less of Tri-calcium Silicate and more of free lime. After the addition of water to cement it sets and hardens due to the hydration and hydrolysis of the above compounds which act as a glue. The aluminate is the first to set and harden, Tri-Silicate is slower and the Di-Silicate is the slowest.

Further early gain in strength is due to Tri-Silicate. Di-Silicate takes 14 to 28 days to add to the strength. All the compounds in their action with water give out heat. **Maximum heat** giving compound is the aluminate which is responsible for most of the undesirable properties of concrete. Cement having lesser **aluminate** shall have less initial strength but higher ultimate strength. Also there shall be lesser generation of heat, more volumetric stability, lesser cracking and more resistance to acid attacks. Incomplete burning of clinker leaves free lime in it. This free lime causes expansion and disruption of concrete after use. The **silicates** form a gel with water. The gel fills the pores of cement thereby making it impervious. The gel later on crystallizes and firmly binds the particles.

### Raw Materials

#### *Calcareous:*

Material having high content of lime.

#### *Argillaceous:*

Material having high contents of silica and alumina.

#### *Siliceous:*

Material having high content of Silica

### Manufacturing Process Flow Diagram

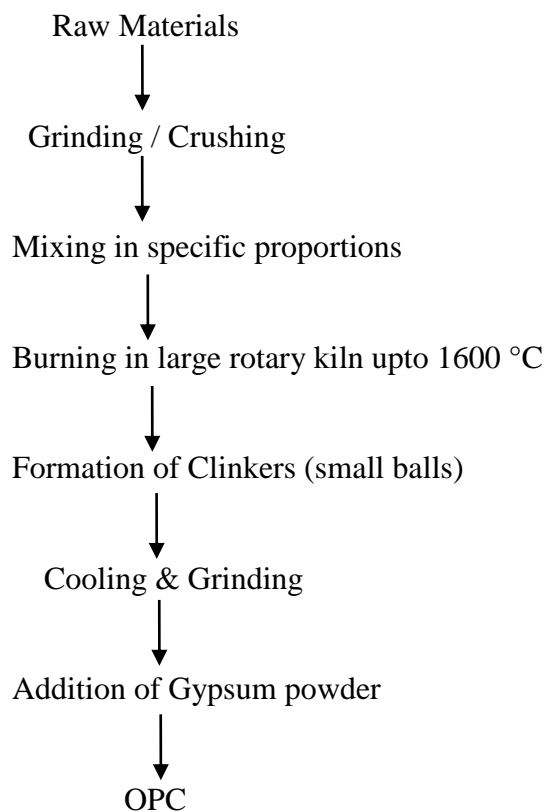

**Manufacture of Cement**

**Wet Process**

a) **Mixing:** The crushed raw materials in desired proportions are fed into ball mills. A little water is added to it. Ball mill is a rotating steel cylinder in which there are hardened steel balls. When the mill rotates the steel balls pulverize the raw materials which form into a solution with water. This liquid mixture is known as slurry. This slurry is then passed into storage tanks known as silos where their proportioning is finally adjusted to ensure the correct chemical composition. Composition of raw mix can be controlled better by the wet process than in dry process. Corrected slurry is then fed into the rotary kiln for burning.

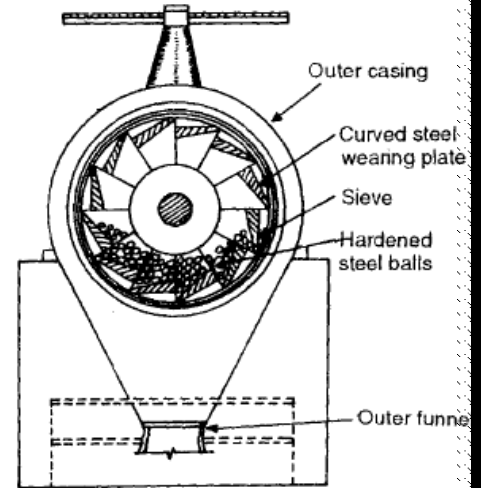

**Ball Mill**

b) **Burning:** Slurry on entering the furnace loses moisture and forms into small lumps or "nodules". The nodules gradually roll down passing through zones of rising temperature until they reach burning zone where they are finally burnt at 1500 to 1650° C. At this temperature "nodules" changes to clinkers. Clinkers are air cooled in another inclined tube similar to the kiln but of lesser length.

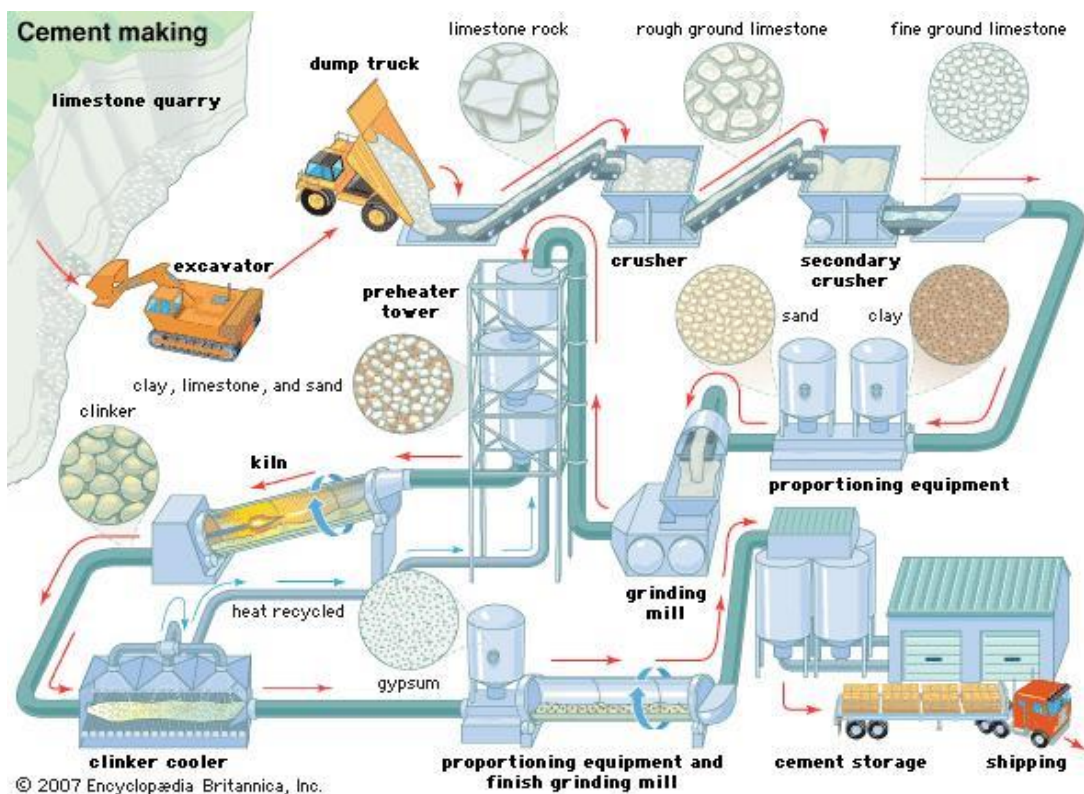

**Cement Manufacturing Process**

c) **Grinding:** Grinding of the clinker is done in large tube mills which are kept cool by spraying water on them from outside. While grinding the clinker, **three to four per cent** gypsum (Calcium Sulphate) is added so as to control the setting time of cement. Finely ground cement is stored in silos from where it is drawn for packing.

### **Storage of Cement**

Portland cement is a finely ground material. It readily absorbs moisture from the atmosphere. It is, therefore, essential to protect it from dampness during storage. Lack of proper care may cause setting of cement or reduction in its strength due to partial setting. **Following precautions** should be taken in storing the cement:

- (i) Walls, roof and floor of the building in which cement is to be stored should be completely waterproof.
- (ii) In case the cement store building is newly constructed then its interior should have been thoroughly dried before the cement is stored in it.
- (iii) Doors and windows should be properly fitted and should be kept shut / closed.
- (iv) Except in case of dry concrete floor, the cement bags should be stacked on wooden planks.
- (v) The bags should be stacked little away from walls. A gap of 6" all around should be left between the exterior walls and the piles.
- (vi) Bags should be piled close together.
- (vii) Bags should be piled not more than 15 bags high or 2 m height.
- (viii) Each incoming consignment should be stacked separately and a placard bearing date of arrival of the consignment should be pinned to it. This would help in using cement in the same order as it arrives, thereby avoiding dead storage that is a stack remaining in positing for a long time while other consignments of cement come in and go out.
- (ix) For temporary storage of cement at site of work, bags should not be stacked on the ground. Minimum number of bags required should be piled upon raised dry platform and covered with polythene sheets.
- (x) Long storage of cement reduces its strength even if all cares are exercised.

#### **Duration of Storage**

#### **%age Reduction in Strength**

1 Months	2%
3 Months	5%
6 Months	upto 40%

**Types of Portland Cement:**

The amounts of the four basic ingredients can be varied to produce different types of Portland cement, each with some unique characteristics. The three most common types are

- (i) Type 1 (ASTM Type I), Normal Portland Cement;
- (ii) Type 3 (ASTM type III) ,High-Early-strength Portland Cement
- (iii)Type 5 (ASTM Type V), Sulfate-Resistant Portland Cement.

In addition, two other types are made;

- (i) Type 2 (ASTM Type II), Moderate Portland Cement
- (ii) Type 4 (ASTM Type IV), Low-Heat-of-Hydration Portland Cement.

**Normal Portland (Type 1) Cement**

Normal Portland (Type 1) cement is used for general construction works when the special properties of the other types are not required. It is normally used for reinforced-concrete, buildings, bridges, pavements and sidewalks where the soil conditions are normal, for most concrete & masonry units, and for all uses where the concrete is not subject to special sulfate hazard or where the heat generated by the hydration of the cement is not objectionable.

**Moderate Portland (Type 2) Cement**

Moderate Portland (Type 2) cement has better resistance to the action of sulfates than normal Portland cement and is used where sulfate concentrations in the soil or ground waters are higher than normal but not unusually severe. It also generates heat at slower rate than normal Portland cement and is used in mass concrete works. Its use will minimize temperature rise, a property which is particularly important when concrete is being placed in hot weather.

**High-Early-Strength Cement (Type 3)**

High-early-strength cement (Type 3) is used where higher strengths are required at early periods, usually of a week or less. It is particularly useful where it is required to remove form work as soon as possible or when the structure is brought into service quickly. High early strength makes it possible to reduce the period of protection for concrete during cold weather.

**Low-Heat Portland Cement (Type 4)**

Low-heat Portland cement (Type 4) is special cement for use where the amount and rate of heat generated must be kept minimum. Strength is also developed at a slower rate. It is

intended for use in massive concrete structures, such as dams, where the temperature rise resulting from heat generated during hydration is a critical factor.

### **Sulfate-Resistant Cement (Type 5)**

Sulfate-resistant cement (Type 5) is intended for use in structures subject to attack by sulfate concentrations in some waters or grounds, such as may be found in certain manufacturing plants or in the ground-water in certain areas. It is also resistant to the action of seawater.

The rate at which the strength of concrete increases varies according to the type of cement used, is shown in the following Table which gives the approximate strength values of concrete for each of the five types at four time periods. Concrete made with normal Portland cement is the basis for comparison.

**Approximate Relative Strength of Concrete As Affected By Type of Cement**

Types of Portland Cement	Compressive Strength-Percent of Strength of Normal (Type I) Portland-Cement Concrete			
	1 Day	7 Days	28 Days	3 Months
1 Normal	100	100	100	100
2 Moderate	75	85	90	100
3 High-early-strength	190	120	110	100
4 Low-heat	55	55	75	100
5 Sulfate-resistant	65	75	85	100

### **Properties of Portland Cement**

Normally, during the manufacture of cement, quite close limits are placed on the chemical composition and some of the physical properties of the material. Frequent tests are carried out on the cement itself, either on hardened cement paste or on concrete made from the cement, to maintain the quality within specification limits.

**Fineness** is one of the important physical properties of cement. Fineness affects the rate of hydration: the finer the cement, the faster strength development takes place. The effects of greater fineness on strength are particularly noticeable during the first 7 days. Also, as fineness increases, the amount of water required for a constant slump concrete decreases, to the limits reached by the higher ranges of fineness in high-early-strength cement.

**Soundness** is a physical property tested by determining the ability of a hardened cement paste to retain its volume after setting. Lack of soundness is caused by too much hard burned free lime or magnesia in the cement.

**Setting** time is an important characteristic of cement which must be regulated. It is necessary for concrete to remain plastic long enough for finishing operations to be carried out. In practical circumstances, the length of time that a concrete mixture will remain plastic is usually more dependent on the amount of mixing water used and the atmospheric temperature than on the setting time of the cement.

**False Set** is a characteristic which results in loss of plasticity, (without much heat being developed) a short time after the concrete is mixed. Further mixing without the additional use of water usually restores the plasticity. The use of chemical admixtures may be beneficial to delay the occurrence of false set. The rapid development of rigidity in a freshly mixed Portland **cement** paste, mortar, or concrete without the evolution of much heat.

**Compressive Strength** is the most important ability of cement which is developed in a concrete mixture. Compressive strength is determined by conducting tests on 2-in (50-mm) mortar cubes, in which standard sand is used. Strength tests at various ages or time intervals indicate the strength-producing characteristics of the cement but should not be used to predict concrete strengths accurately because of the great number of variables that may occur in a number of concrete mixtures. To determine accurately the compressive strength of concrete tests should be made on concrete samples made from the particular ingredients to be used.

**Heat of hydration** is the heat produced by the chemical reaction between cement and water. The amount and rate of heat generated depends on the chemical composition of the cement, fineness of the cement and the temperature during hydration. In some structures with considerable mass, the rate and amount of heat generated are significant. If the heat is not rapidly dissipated, an undesirable rise in temperature may occur, which may be accompanied by thermal expansion. A subsequent drop in temperature may then create undesirable stresses in the structure. On the other hand, a rise in temperature may be beneficial in cold weather, helping to maintain favorable curing conditions. The approximate amount of heat generated during the first seven days by each of the five types of cement, based on 100 percent for Type 1 or normal Portland cement, are shown in Table.



**Specific Gravity** of Portland cement is generally about 3.15. Cements made from materials other than limestone and clay may vary somewhat from the above value. Specific gravity is not an indication of the quality of the cement. It is used in calculating mix design proportions.

### **Comparative Amounts of Heat Generated During First 7 Days By Five Types Of Cement**

Cement Type	Heat Generated, %
Type 1 or normal	100
Type 2 or moderate	80-85
Type 3 or high-early-strength	Up to 150
Type 4 or low-heat	40-60
Type 5 or sulfate-resistant	60-75

### **Tests on Physical Properties of Cement**

- Consistency test
- Setting Time test
- Soundness test
- Fineness test
- Strength test

### **BS 12:1978 Requirements for Strength of Ordinary Portland Cement**

Age (days)	Min Compressive Strength (psi)	
	Mortar Cube	Concrete Cube
3	3300	1900
28	5900	4200

### **According to PSS 232-1983(R)**

Min. Compressive Strength of Mortar Cube (psi)	
3-days	2200
7-days	3400
28-days	5000

## **Special Cements**

### **1. White Portland Cement**

White Portland cement is manufactured according to the specifications of ASTM C-150 and is very similar to normal Portland cement except in color. It is made from specially selected raw materials containing negligible amounts of iron and manganese oxide, and manufacturing process is controlled to produce a pure white, non staining cement. It is used primarily for architectural purposes such as curtain-wall and facing panels, decorative concrete, stucco, tile grout, in floors or wherever white or colored concrete or mortar is specified.

### **2. Masonry Cement**

Masonry cement has been specially designed to produce better mortar than that made with normal Portland cement or with a lime cement combination. It is made by grinding together a carefully proportioned mixture of normal Portland cement clinker and high-calcium limestone. To the finely ground product an air-entraining agent, a plasticizing agent, and a set retarder are added.

The mortar made with this cement has particularly good plasticity and workability, good adhesion and bond, and has adequate strength to meet the requirements of ASTM C-91. It also offers great resistance to efflorescence and has good appearance.

### **3. Rapid Hardening Cement**

This cement is very similar to OPC but develops strength more rapidly. Its three-day strength is equal to seven-day strength of OPC with the same water cement ratio. The increased gain of rate of strength is achieved by having high contents of C3A. Rapid gain of strength corresponds to high rate of heat of hydration development. So, it should not be used in massive constructions or in large structural sections. However, in low temperature areas the use of rapid hardening cement may prove a safeguard against early frost damage.

### **4. Ultra High Early Strength Cement**

This cement contains no admixtures and is therefore, suitable for reinforced and pre-stressed concrete. The early strength development is due to very high fineness of the cement and for this purpose Gypsum contents are to be high. This cement is manufactured by separating fines from rapid hardening cement. It deteriorates rapidly on exposure to air. The three-day

strength of rapid hardening cement is reduced to 16 hours and seven-day strength to 24 hours, in case of ultra high early strength cement. However, there is a little gain of strength after 28 days.

### **5. Hydrophobic Cement**

This cement is used where long storage under unfavorable conditions is required. It is obtained by inter-grinding Portland cement with 0.1-0.4% oleic acid, stearic acid or pentachlorophenol can also be used. The hydrophobic properties are due to formation of water repellent film around each particle of cement. Thin film is broken during mixing of concrete and normal hydration takes place but early strength is low. It is similar to OPC in appearance.

### **6. Colored Portland Cement**

These are made by adding pigment to white or some time to grey cement. Its strength is comparatively lower than normal Portland cement and 10-15% additional cement has to be used to maintain the strength.

### **7. Ballast Slag Cement**

Adding about 35% by weight ballast furnace slag to OPC clinkers before grinding makes this mixture as slag cement. Slag is a waste item in the manufacturing of pig iron, the quantity of iron and slag obtained being of the same order usually. The slag is a mixture of Lime, Silica and Alumina, the same oxides as in Portland cement but not in that proportions. Individual composition is Lime 42%, Silica 30%, Alumina 19%, Magnesia 5% and alkalies 1%. Its heat of hydration is low, which is beneficial for massive constructions but not suitable in cold weather. It has excellent Sulphate resisting properties, so generally used in foundations.

### **8. Extra Rapid Hardening Cement**

This cement is obtained by intergrinding Calcium Chloride with rapid hardening cement. The quantity of Calcium Chloride should not exceed 2%. This cement is particularly suitable for cold weather concreting or when high early strength is required. However, its use with steel reinforcement is not recommended. The strength of extra rapid hardening

cement is about 25% higher than that of rapid hardening cement at 1 or 2 days and 10-20% higher at 7-days. The setting time of this cement is quite less so early placing is essential.

#### **9. Acid Resistance Cement:**

This is consists of acid resistance aggregates such as quartz, quartzite's, etc, additive such as sodium fluoro silicate ( $\text{Na}_2\text{SiO}_6$ ) and aqueous solution of sodium silicate. This is used for acid resistant and heat resistant coating of installations of chemical Industry. By adding 0.5 percent of unseed oil or 2 percent of ceresil, its resistance to water is increased and known as acid water resistant cement.

#### **10. Pozzuolona Cement:**

Pozzuolona is a volcanic powder and the percentage should be between 10 to 30.

#### **Advantages**

1. It attains compressive strength with age.
2. It can resist action of sulphates.
3. It evolves less heat during setting.
4. It imparts higher degree of water tightness.
5. It imparts plasticity and workability to mortar and concrete prepared from it.
6. It offers great resistance to expansion
7. It possesses higher tensile strength

#### **Disadvantages:**

1. Compressive strength in early days is less.
2. It possesses less resistance to erosion and weathering action.