

UTILIZATION OF ELECTRICAL
ILLUMINATION FUNDAMENTALS

Introduction:

Light is the prime factor in the human life as well as activities of human beings ultimately depend upon the light. Where there is no natural light, use of artificial light is made. Artificial lighting produced electrically, on account of its cleanness, ease of control, reliability, steady output, as well as its low cost it is playing an increasingly important part in modern every day life. The science of illumination engineering is, therefore, becoming of major importance.

Nature of light:

Light is a form of radiant energy. Various forms of incandescent bodies are the sources of light and the light emitted by such bodies depend upon the temperature of bodies. Heat energy is radiated into the medium by a body which is hotter than the medium surrounding it. The heat of the body, as seen, can be classified as red hot or white-hot. While the body is red-hot the wave length of radiated energy will be sufficiently large and the energy available is in the form of heat. When the temperature increases the body changes from red-hot to white-hot state, the wave length of the energy radiated becomes smaller and smaller and enter into the range of the wave length of the light.

Colour: The sensation of colour is due to the difference in the wave lengths of the light radiations. Visible light can have wave lengths of the light between 4,000Å and 7,500Å and the colour varies in the way as shown in the figure.

Relative sensitivity:

The sensitivity of the eye to the lights of different wave lengths varies from person to person and according to the age. The average relative sensitivity is shown in the following figure. The eye has greatest sensitivity for wave lengths of about 5,500Å: that is yellow-green can be seen under such poor conditions of illumination when blue or red can not be seen under dim illumination, the sensitive curve shifts as shown by the shaded region in the following figure. Therefore, violet disappears first and red remains visible. Yellow disappears last as the illumination becomes very dim. As each colour disappears, it becomes a grey shade and finally black. The sensitivity of eye to yellow-green radiation is taken as unity or 100% and the sensitivity to other wave lengths is expressed as a fraction or percentage of it. The relative sensitivity at a wave length λ is written k_{λ} and is known as *relative luminosity factor*.

UTILIZATION OF ELECTRICAL

Illumination:

Illumination differs from light every much, though generally these terms are used more or less synonymously. Strictly speaking light is the cause and illumination is the result of that light on surfaces on which it falls. Thus the illumination makes the surface look more or less bright with certain colour and it is this brightness and colour which the eye sees and interrupts as something useful or pleasant or other wise.

Light may be produced by passing electric current through filaments as in the incandescent lamps, through arcs between carbon or metal rods, or through suitable gases as in neon and other gas tubes. In some forms of lamps the light is due to fluorescence excited by radiation arising from the passage electric current through mercury vapour.

Some bodies reflect light in some measure, and when illuminated from an original source they become secondary source of light. The good example is the moon, which illuminates earth by means of the reflected light originating in the sun.

Terms used in illumination:

The modern lighting schemes and the selection of fittings and type of lamps require knowledge of the terms and quantities in general use for such purposes. Therefore, the following definitions are given in simple form to facilitate easy identification and reference.

Light: It is defined as the radiation energy from a hot body which produces the visual sensation upon the human eye. It is usually denoted by Q, expressed in lumen-hours and is analogous to watt-hour.

Luminous flux: it is defined as the total quantity of light energy emitted per second from a luminous body. It is represented by symbol F and is measured in lumens. The concept of luminous flux helps us to specify the output and efficiency of a given light source.

Luminous intensity: luminous intensity in any given direction is the luminous flux emitted by the source per unit solid angle, measured in the direction in which the intensity is required. It is denoted by symbol I and is measured in candela(cd) or lumens/steradian.

If F is the luminous flux radiated out by source within a solid angle of ω steradian in any particular direction then $I = \frac{F}{\omega}$ lumens/steradian or candela (cd).

Lumen: the lumen is the unit of luminous flux and is defined as the amount of luminous flux given out in a space represented by one unit of solid angle by a source having an intensity of one candle power in all directions.

$$\text{Lumens} = \text{candle power} \times \text{solid angle} = \text{cp} \times \omega$$

Total lumens given out by source of one candela are 4π lumens.

Candle power: Candle power is the light radiating capacity of a source in a given direction and is defined as the number of lumens given out by the source in a unit solid angle in a given direction. It is denoted by a symbol **C.P.**

UTILIZATION OF ELECTRICAL

$$\text{C.P.} = \frac{\text{lumens}}{\omega}$$

Illumination: When the light falls upon any surface, the phenomenon is called the illumination. It is defined as the number of lumens, falling on the surface, per unit area. It is denoted by symbol E and is measured in lumens per square meter or meter-candle or lux.

If a flux of **F** lumens falls on a surface of area **A**, then the illumination of that surface is $E = \frac{F}{A}$ lumens/m² or lux

Lux or meter candle: It is the unit of illumination and is defined as the luminous flux falling per square meter on the surface which is every where perpendicular to the rays of light from a source of one candle power and one meter away from it.

Foot candle: It is also the unit of illumination and is defined as the luminous flux falling per square foot on the surface which is every where perpendicular to the rays of light from a source of one candle power and one foot away from it.

$$1 \text{ foot-candle} = 1 \text{ lumen/ft}^2 = 10.76 \text{ meter candle or lux}$$

Candle: It is the unit of luminous intensity. It is defined as $\frac{1}{60}$ th of the luminous intensity per cm² of a black body radiator at the temperature of solidification of platinum (2,043⁰K).

Mean horizontal candle power: (M.H.C.P) It is defined as the mean of candle powers in all directions in the horizontal plane containing the source of light.

Mean spherical candle power: (M.S.C.P) It is defined as the mean of the candle powers in all directions and in all planes from the source of light.

Mean hemi-spherical candle power: (M.H.S.C.P) It is defined as the mean of candle powers in all directions above or below the horizontal plane passing through the source of light.

Reduction factor: Reduction factor of a source of light is the ratio of its mean spherical candle power to its mean horizontal candle power.

$$\text{i.e reduction factor} = \frac{M.S.C.P}{M.H.C.P}$$

Lamp efficiency: It is defined as the ratio of the luminous flux to the power input. It is expressed in lumens per watt.

Specific consumption: It is defined as the ratio of the power input to the average candle power. It is expressed in watt per candela.

Brightness or luminance: When the eye receives a great deal of light from an object we say it is bright, and brightness is an important quantity in illumination. It is all the same whether the light is produced by the object or reflected from it.

Brightness is defined as the luminous intensity per unit projected area of either a surface source of light or a reflecting surface and is denoted by L.

UTILIZATION OF ELECTRICAL

If a surface area A has an effective luminous intensity of I candelas in a direction θ to the normal, then the brightness (luminance) of that surface is

$$L = \frac{I}{A \cos \theta} \text{ candela/m}^2 \text{ or nits}$$

Nit is defined as the candela per square meter. Bigger unit of brightness (luminance) is Stilb which is defined as candelas per square cm. lambert is also the unit of brightness which is lumens/cm². Foot lambert is lumens/ ft².

Glare:- The size of the opening of the pupil in the human eye is controlled by its iris. If the eye is exposed to a very bright source of light the iris automatically contracts in order to produce the amount of light admitted and prevent damaged to retina this reduces the sensitivity, so that other objects within the field of vision can be only imperfectly seen. In other words glare maybe defined as brightness with in the field of vision of such a character as the cause annoyance discomfort interference with vision.

Space height ratio:- it is defined as the ratio of distance between adjacent lamps and height of their mountains.

$$\text{Space height ratio} = \frac{\text{horizontal distance between two adjacent lamps}}{\text{mounting height of lamps above working plane}}$$

Utilization factor or co-efficient of utilization:- It is defined as the ratio of total lumens reaching the working plane to total lumens given out by the lamp.

$$\text{Utilization factor or co-efficient of utilization} = \frac{\text{total lumens reaching the working plane}}{\text{total lumens given out by the lamp}}$$

Maintenance factor: Due to accumulation of dust, dirt and smoke on the lamps, they emit less light than that they emit when they are new ones and similarly the walls and ceilings e.t.c. after being covered with dust, dirt and smoke do not reflect the same output of light, which is reflected when they are new.

The ratio of illumination under normal working conditions to the illumination when the things are perfectly clean is known as maintenance factor.

$$\text{Maintenance factor} = \frac{\text{illumination under normal working conditions}}{\text{illumination when every thing is clean}}$$

Depreciation factor: this is merely reverse of the maintenance factor and is defined as the ratio of the initial metre-candles to the ultimate maintained metre-candles on the working plane. Its value is more than unity.

Waste light factor: Whenever a surface is illuminated by a number of sources of light, there is always a certain amount of waste of light on account of over-lapping and falling of light outside at the edges of the surface. The effect is taken into account by multiplying the theoretical value of lumens required by 1.2 for rectangular areas and 1.5 for irregular areas and objects such as statues, monuments etc.

Absorption factor: In the places where atmosphere is full of smoke fumes, such as in foundries, there is a possibility of absorption of light. The ratio of total lumens available after absorption to the total lumens emitted by the source of light is called the absorption factor. Its value varies from unity for clean atmosphere to 0.5 for foundries.

UTILIZATION OF ELECTRICAL

Beam factor: the ratio of lumens in the beam of a projector to the lumens given out by lamps is called the beam factor. This factor takes into the account the absorption of light by reflector and front glass of the projector lamp. Its value varies from 0.3 to 0.6.

Reflection factor: When a ray of light impinges on a surface it is reflected from the surface at an angle of incidence, as shown in the following figure. A certain portion of incident light is absorbed by the surface. The ratio of reflected light to the incident light is called the **reflection factor**. It's value always less than unity.

Solid angle: Plane angle is subtended at a point in a plane by two converging straight lines and its magnitude is given by

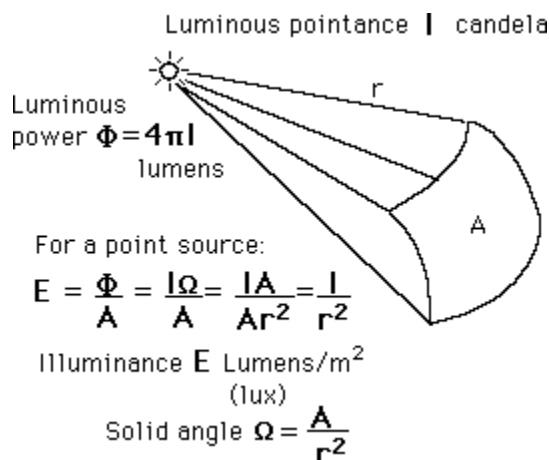

$$\theta = \frac{\text{arc}}{\text{radius}} \text{ radians}$$

The largest angle subtended at a point is 2π radians.

Solid angle is the angle generated by the surface passing through the point in space and the periphery of the area. Solid angle is denoted by ω , expressed in steradians and is given by the ratio of the area of the surface to the square of the distance between the area and the point.

$$\text{i.e } \omega = \frac{\text{Area}}{(\text{Radius})^2} = \frac{A}{r^2}$$

The largest solid angle subtended at a point is that due to a sphere at its centre. If r is the radius of any sphere, its surface area is $4\pi r^2$ and the distance of its surface area from the centre is r , therefore, solid angle subtended at its centre by its surface, $\omega = \frac{4\pi r^2}{r^2} = 4\pi$ steradians

Steradian: It is the unit of solid angle and is defined as the solid angle that subtends a surface on the sphere equivalent to the square of the radius.

Laws of illumination:- There are two laws of illumination

1. Law of inverse squares

UTILIZATION OF ELECTRICAL

2. lamberts cosine law

1. Law of inverse squares:- If a source of light which emits light equally in all directions be placed at the center of the hollow sphere, the light will fall uniformly on the inner surface of the sphere that is to say, each square mm of the surface will receive the same amount of light. If the sphere be replaced by one of the larger radius, the same total amount of light is spread over a larger area proportional to the square of the radius. The amount which falls upon any square mm of such a surface will therefore diminishes as the radius increases, and will be inversely proportional to the square of the distance

A similar relation holds if we have to deal with a beam of light in the form of a cone or pyramid as shown in the fig. if we consider parallel surfaces which cut the pyramid at different distances from the source, the areas of these surfaces are proportional to the square of these distances, and therefore the amount of light which falls on the one unit of the area of these surfaces is inversely proportional to the square of the distances from the source. This relation is referred to as the law of inverse squares. Mathematically it can be proved as follows:

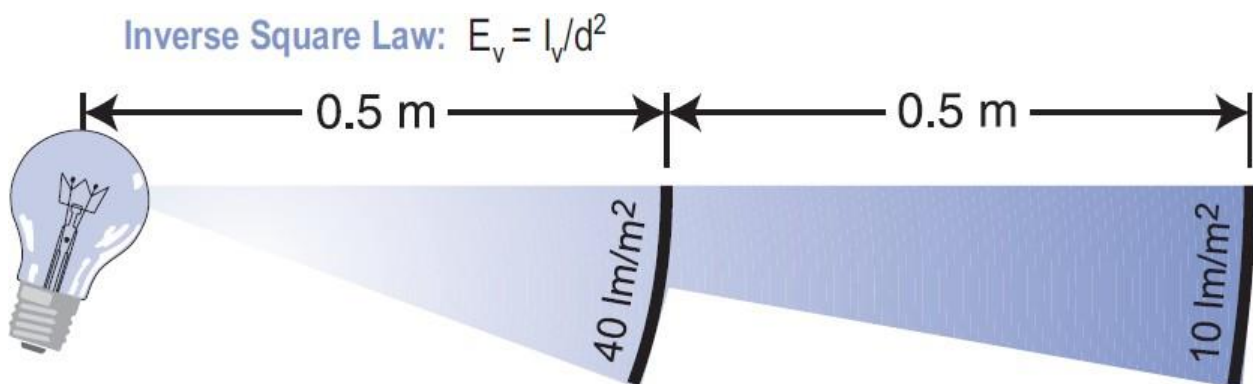

Polar curves :-

All over discussions so far were based on the assumption that luminous intensity or the candle power from a source is uniformly distributed over the surrounding surface. But none of the practical type of lamp gives light uniformly distributed in all directions because of its unsymmetrical shapes. It is often necessary to know the distribution of light in various directions to ascertain how the candle power of light source varies in different directions. The luminous intensity in all directions can be represented by polar curves. If the luminous intensity in a horizontal plane passing through the lamp is plotted against angular position, a curve known as horizontal polar curve is obtained. If the luminous intensity in a vertical plane is plotted against the angular position, a curve known as vertical polar curve is obtained. The typical polar curves for an ordinary filament lamp are shown in the following fig:

UTILIZATION OF ELECTRICAL

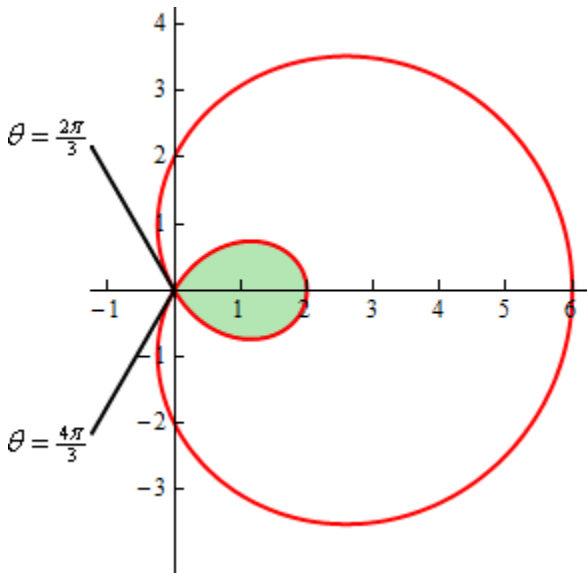

The polar curves are used to determine the mean horizontal candle power (m.h.c.p.) and mean spherical candle power (m.s.c.p.). these are also used to determine the actual illumination of a surface by employing the candle power in that particular direction as read from the vertical polar curve in the illumination calculations.

The mean horizontal candle power of a lamp can be determined from the horizontal polar curve taking the mean value of the candle power in a horizontal direction.

Mean spherical candle power can be determined from the vertical polar curve by Rousseau's construction.

Rousseau's construction: The construction is illustrated in the following figure. A semi circle of any convenient radius is drawn with the pole of the polar diagram as centre. The line CD is drawn equal and parallel to the vertical diameter YY^1 . Now from this line CD ordinate equal to corresponding radius on the polar curve are set up such as $BD = OK$, $GH = Of$ and so on. The curve obtained by joining the ends of these ordinates is known as Rousseau's curve. The mean ordinate of this curve gives the m.s.c.p. of the lamp having polar curve given as in the following figure.

$$\text{The mean ordinate of the curve} = \frac{\text{Area CSTGDBHLC}}{\text{Length of CD}}$$

The area under the curve can either be determined on the graph paper or found by Simpson's rule.

UTILIZATION OF ELECTRICAL

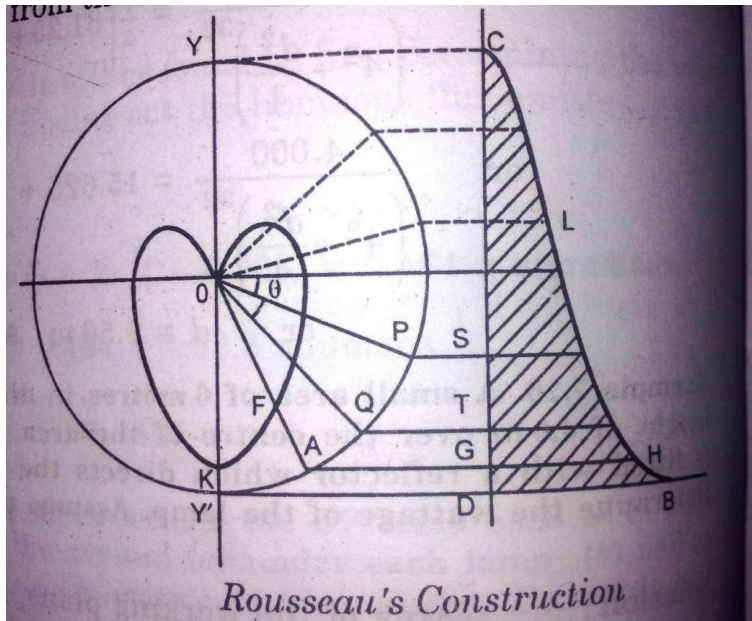

Photometry: -

The candle power of a source in any given direction is measured by comparison with a standard or substandard source employing photometer bench and some form of photometer. The experiment is performed in dark room with dead black walls and ceiling in order to eliminate the errors due to reflected light.

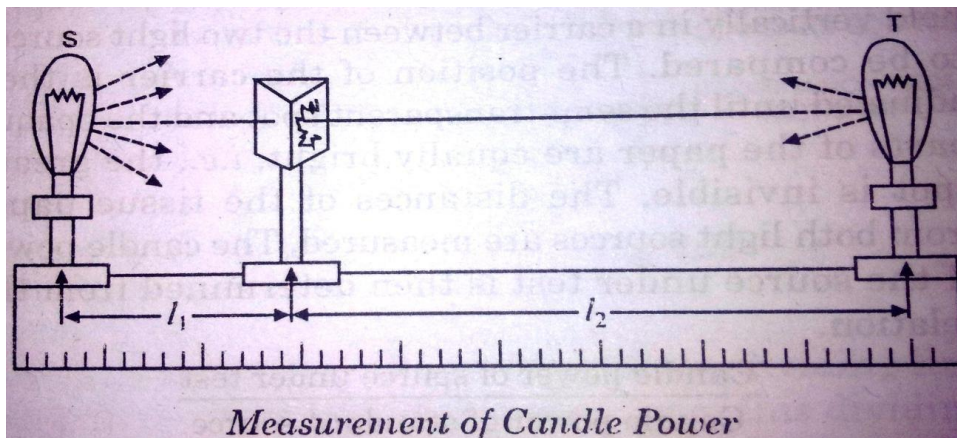

The photometer bench consists essentially of two steel rods which carry the stands or saddles for holding the two sources, the carriage for the photometer head and for any other operators employed in making measurements. One of the bar carries a bar strip, graduated in centimeters and millimeters the carriages which slides upon the bench have expect that carrying the photometer head, a circular table which can be rotated in a horizontal plane and clamped in any position. The circular table is provided with a scale graduated in degrees round its edge so that the angle of rotation of lamp from the direction of the axis of bench can be measured. The bench should be rigid so that the source is being compared may be free from vibrations and carriage holding the photometer head should be capable of moving smoothly and with every little effort. The photometer head acts as a screen for comparison of illumination of the standard source and the source under test. There are different types of photometers, which can be used for the purpose. Some of them are described here.

The principle of the most methods of measurement is based upon the inverse square law.

UTILIZATION OF ELECTRICAL

The standard source, whose candle power is known (say S) and the source under test whose candle power is to be determined, are set on the bench at a distance apart with some type of screen in line with, and between, them as shown in the above figure. The photometer head or screen is moved in between the two fixed sources until the illumination on the both sides of the screen is same. If the distance of the standard source S and source under test T from photometer head are l_1 and l_2 respectively then according to inverse square law.

$$\frac{\text{Candle power of source under test}}{\text{Candle power of standard source}} = \frac{l_2^2}{l_1^2}$$

$$\text{Candle power of source under test} = S \times \frac{l_2^2}{l_1^2}$$

➤ Integrating sphere:-

It is a source of apparatus which is now commonly employed for measurements of mean spherical candle power. In this method the sphere is used to measure the total flux radiated by the lamp, which when divided by 4π gives as m.s.c.p. Since in this method the flux radiated in all directions is taken into account, so this method is better than that described in which it was assumed that the candle power distribution is same in all vertical planes, an assumption which may not always be justifiable.

The integrating sphere consists of a hollow sphere whose diameter is large compared to the lamp to be tested having a smooth inner surface with a uniform coating of white paint. If the lamp is hung inside the sphere, the light is so diffused an uniform illumination is produced over the whole surface. A small window of translucent glass provided at one side of the sphere is illuminated by reflecting light from the inner surface of the sphere. The small screen is inserted in between the lamp and window in order to prevent the light from the lamp reaching the window directly.

➤ Source of light:- According to the principle of operation of light source maybe grouped as follows:

1. **Arc lamps**: - Electric discharge through air gives intense light. This principle is utilized in arc lamps.
2. **High temperature**: - Oil and gas lamps and incandescent filament type lamps, which emit light when heated to high temperature.
3. **Gaseous discharge lamps**: - Under certain conditions it is possible to pass electric current through a gas or metal vapor, which is accompanied by visible radiation. Sodium and mercury vapor lamps operate on this principle.
4. **Fluorescent type lamps**: - Certain materials, when exposed to ultra violet rays, the absorbed energy into the radiation of longer wave length lying within the visible range. This principle is employed in fluorescent lamps.