

Experiment: 2

Measurement of Unknown Resistance by using Wheatstone Bridge Method.

EQUIPMENTS

- DC Power Supply.
- DC Current Source.
- Few Resistors.
- Digital Multimeter.
- Wheatstone Bridge equipment.

THEORY

The Wheatstone bridge is the most widely used circuit for precisely measuring resistance by the comparison method. The bridge is named after Charles Wheatstone who invented it in 1843.

Wheatstone Bridge Equipment Description:

The Wheatstone Bridge is designed to be used for precision resistance measurements in the Laboratory. Values of resistance from 0.001 to 9,999,000 ohms can be measured with this instrument. When the instrument is used as a Wheatstone bridge, the Ratio Multiplier switch allows selection of seven multipliers from 0.001 to 1,000. Multiplying the reading obtained from the decade dials by the ratio selected yields the value, in ohms, of the unknown resistance. Ratio resistances are accurate to $\pm 0.05\%$. The zero-center, null-point-indicating galvanometer has a sensitivity of $0.5 \mu\text{A}/\text{div}$.

PROCEDURE

Simplified Wheatstone Bridge:

A simplified Wheatstone bridge circuit is shown in Figure 2.1. In the figure, R_1 , R_2 and R_3 are adjustable resistances and X is the unknown resistance. You are required to measure the unknown resistance X .

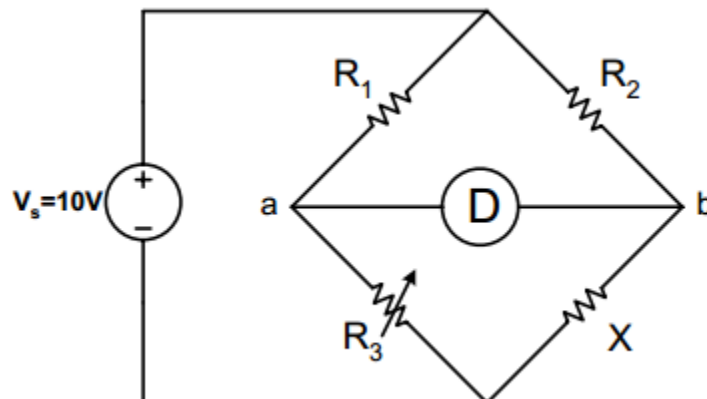

Figure 2.1 (Wheatstone Bridge)

1. Connect the power supply and resistances as shown in figure 2.1.
2. Now vary resistances R3 until the volt-meter deflection is zero.
3. Now using the following formula, the unknown resistance X can be determined:

$$R_1 X = R_2 R_3 \quad (2.1)$$

$$X = \frac{R_2 R_3}{R_1} \quad (2.2)$$

R₁	R₂	R₃	X

Table 2.1 (Observations)

2. Measurement of Resistance using Wheatstone Bridge:

1. To measure the unknown resistance, set the Ratio Multiplier to “1.0” and set all decade dials to “5”.
2. Tap the “Low” Galvanometer Sensitivity key and note the direction of the galvanometer deflection.
3. When the direction of the galvanometer deflection is determined, change the Ratio Multiplier one step at a time until the galvanometer deflection reverses direction.
4. Vary the 1000-ohm decade dial to make the deflection a minimum. Continue to decrease the deflection by varying the 100-ohm decade dial, the 10-ohm decade dial and finally the 1-ohm decade dial.
5. Depress the “High” Galvanometer Sensitivity key and, if necessary, further adjust the decade dials for zero galvanometer deflection.
6. When the bridge is balanced the value of unknown resistance is equal to the product of the Ratio Multiplier and the decade reading.

Resistor (Nominal Value)	100 Ω	1 K Ω	10 K Ω
Ohm-meter Reading			
Wheatstone Bridge Reading			

Table 2.2 (Observations Wheatstone Bridge)

