

Circuit Theorems

Your success as an engineer will be directly proportional to your ability to communicate!

—Charles K. Alexander

Enhancing Your Skills and Your Career

Enhancing Your Communication Skills

Taking a course in circuit analysis is one step in preparing yourself for a career in electrical engineering. Enhancing your communication skills while in school should also be part of that preparation, as a large part of your time will be spent communicating.

People in industry have complained again and again that graduating engineers are ill-prepared in written and oral communication. An engineer who communicates effectively becomes a valuable asset.

You can probably speak or write easily and quickly. But how *effectively* do you communicate? The art of effective communication is of the utmost importance to your success as an engineer.

For engineers in industry, communication is key to promotability. Consider the result of a survey of U.S. corporations that asked what factors influence managerial promotion. The survey includes a listing of 22 personal qualities and their importance in advancement. You may be surprised to note that “technical skill based on experience” placed fourth from the bottom. Attributes such as self-confidence, ambition, flexibility, maturity, ability to make sound decisions, getting things done with and through people, and capacity for hard work all ranked higher. At the top of the list was “ability to communicate.” The higher your professional career progresses, the more you will need to communicate. Therefore, you should regard effective communication as an important tool in your engineering tool chest.

Learning to communicate effectively is a lifelong task you should always work toward. The best time to begin is while still in school. Continually look for opportunities to develop and strengthen your reading, writing, listening, and speaking skills. You can do this through classroom presentations, team projects, active participation in student organizations, and enrollment in communication courses. The risks are less now than later in the workplace.



Ability to communicate effectively is regarded by many as the most important step to an executive promotion.

© IT Stock/Punchstock

4.1 Introduction

A major advantage of analyzing circuits using Kirchhoff's laws as we did in Chapter 3 is that we can analyze a circuit without tampering with its original configuration. A major disadvantage of this approach is that, for a large, complex circuit, tedious computation is involved.

The growth in areas of application of electric circuits has led to an evolution from simple to complex circuits. To handle the complexity, engineers over the years have developed some theorems to simplify circuit analysis. Such theorems include Thevenin's and Norton's theorems. Since these theorems are applicable to *linear* circuits, we first discuss the concept of circuit linearity. In addition to circuit theorems, we discuss the concepts of superposition, source transformation, and maximum power transfer in this chapter. The concepts we develop are applied in the last section to source modeling and resistance measurement.

4.2 Linearity Property

Linearity is the property of an element describing a linear relationship between cause and effect. Although the property applies to many circuit elements, we shall limit its applicability to resistors in this chapter. The property is a combination of both the homogeneity (scaling) property and the additivity property.

The homogeneity property requires that if the input (also called the *excitation*) is multiplied by a constant, then the output (also called the *response*) is multiplied by the same constant. For a resistor, for example, Ohm's law relates the input i to the output v ,

$$v = iR \quad (4.1)$$

If the current is increased by a constant k , then the voltage increases correspondingly by k ; that is,

$$kiR = kv \quad (4.2)$$

The additivity property requires that the response to a sum of inputs is the sum of the responses to each input applied separately. Using the voltage-current relationship of a resistor, if

$$v_1 = i_1R \quad (4.3a)$$

and

$$v_2 = i_2R \quad (4.3b)$$

then applying $(i_1 + i_2)$ gives

$$v = (i_1 + i_2)R = i_1R + i_2R = v_1 + v_2 \quad (4.4)$$

We say that a resistor is a linear element because the voltage-current relationship satisfies both the homogeneity and the additivity properties.

In general, a circuit is linear if it is both additive and homogeneous. A linear circuit consists of only linear elements, linear dependent sources, and independent sources.

A **linear circuit** is one whose output is linearly related (or directly proportional) to its input.

Throughout this book we consider only linear circuits. Note that since $p = i^2 R = v^2 / R$ (making it a quadratic function rather than a linear one), the relationship between power and voltage (or current) is nonlinear. Therefore, the theorems covered in this chapter are not applicable to power.

To illustrate the linearity principle, consider the linear circuit shown in Fig. 4.1. The linear circuit has no independent sources inside it. It is excited by a voltage source v_s , which serves as the input. The circuit is terminated by a load R . We may take the current i through R as the output. Suppose $v_s = 10$ V gives $i = 2$ A. According to the linearity principle, $v_s = 1$ V will give $i = 0.2$ A. By the same token, $i = 1$ mA must be due to $v_s = 5$ mV.

For example, when current i_1 flows through resistor R , the power is $p_1 = Ri_1^2$, and when current i_2 flows through R , the power is $p_2 = Ri_2^2$. If current $i_1 + i_2$ flows through R , the power absorbed is $p_3 = R(i_1 + i_2)^2 = Ri_1^2 + Ri_2^2 + 2Ri_1i_2 \neq p_1 + p_2$. Thus, the power relation is nonlinear.

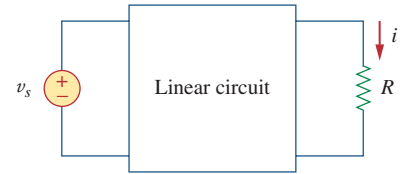

Figure 4.1

A linear circuit with input v_s and output i .

For the circuit in Fig. 4.2, find I_o when $v_s = 12$ V and $v_s = 24$ V.

Example 4.1

Solution:

Applying KVL to the two loops, we obtain

$$12i_1 - 4i_2 + v_s = 0 \quad (4.1.1)$$

$$-4i_1 + 16i_2 - 3v_x - v_s = 0 \quad (4.1.2)$$

But $v_x = 2i_1$. Equation (4.1.2) becomes

$$-10i_1 + 16i_2 - v_s = 0 \quad (4.1.3)$$

Adding Eqs. (4.1.1) and (4.1.3) yields

$$2i_1 + 12i_2 = 0 \quad \Rightarrow \quad i_1 = -6i_2$$

Substituting this in Eq. (4.1.1), we get

$$-76i_2 + v_s = 0 \quad \Rightarrow \quad i_2 = \frac{v_s}{76}$$

When $v_s = 12$ V,

$$I_o = i_2 = \frac{12}{76} \text{ A}$$

When $v_s = 24$ V,

$$I_o = i_2 = \frac{24}{76} \text{ A}$$

showing that when the source value is doubled, I_o doubles.

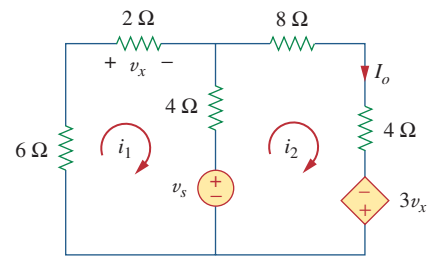

Figure 4.2

For Example 4.1.

For the circuit in Fig. 4.3, find v_o when $i_s = 30$ and $i_s = 45$ A.

Practice Problem 4.1

Answer: 40 V, 60 V.

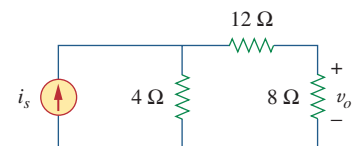

Figure 4.3

For Practice Prob. 4.1.

Example 4.2

Assume $I_o = 1$ A and use linearity to find the actual value of I_o in the circuit of Fig. 4.4.

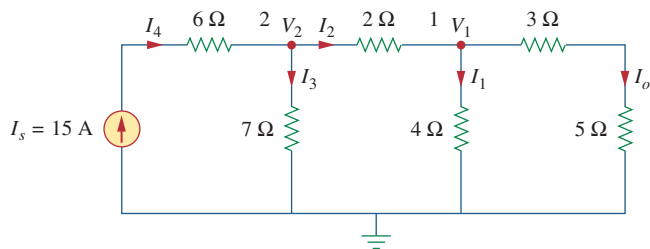

Figure 4.4
For Example 4.2.

Solution:

If $I_o = 1$ A, then $V_1 = (3 + 5)I_o = 8$ V and $I_1 = V_1/4 = 2$ A. Applying KCL at node 1 gives

$$I_2 = I_1 + I_o = 3 \text{ A}$$

$$V_2 = V_1 + 2I_2 = 8 + 6 = 14 \text{ V}, \quad I_3 = \frac{V_2}{7} = 2 \text{ A}$$

Applying KCL at node 2 gives

$$I_4 = I_3 + I_2 = 5 \text{ A}$$

Therefore, $I_s = 5$ A. This shows that assuming $I_o = 1$ gives $I_s = 5$ A, the actual source current of 15 A will give $I_o = 3$ A as the actual value.

Practice Problem 4.2

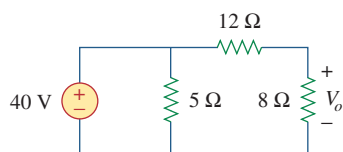

Figure 4.5
For Practice Prob. 4.2.

Assume that $V_o = 1$ V and use linearity to calculate the actual value of V_o in the circuit of Fig. 4.5.

Answer: 16 V.

4.3 Superposition

If a circuit has two or more independent sources, one way to determine the value of a specific variable (voltage or current) is to use nodal or mesh analysis as in Chapter 3. Another way is to determine the contribution of each independent source to the variable and then add them up. The latter approach is known as the *superposition*.

The idea of superposition rests on the linearity property.

Superposition is not limited to circuit analysis but is applicable in many fields where cause and effect bear a linear relationship to one another.

The **superposition** principle states that the voltage across (or current through) an element in a linear circuit is the algebraic sum of the voltages across (or currents through) that element due to each independent source acting alone.

The principle of superposition helps us to analyze a linear circuit with more than one independent source by calculating the contribution of each independent source separately. However, to apply the superposition principle, we must keep two things in mind:

1. We consider one independent source at a time while all other independent sources are *turned off*. This implies that we replace every voltage source by 0 V (or a short circuit), and every current source by 0 A (or an open circuit). This way we obtain a simpler and more manageable circuit.
2. Dependent sources are left intact because they are controlled by circuit variables.

With these in mind, we apply the superposition principle in three steps:

Steps to Apply Superposition Principle:

1. Turn off all independent sources except one source. Find the output (voltage or current) due to that active source using the techniques covered in Chapters 2 and 3.
2. Repeat step 1 for each of the other independent sources.
3. Find the total contribution by adding algebraically all the contributions due to the independent sources.

Analyzing a circuit using superposition has one major disadvantage: It may very likely involve more work. If the circuit has three independent sources, we may have to analyze three simpler circuits each providing the contribution due to the respective individual source. However, superposition does help reduce a complex circuit to simpler circuits through replacement of voltage sources by short circuits and of current sources by open circuits.

Keep in mind that superposition is based on linearity. For this reason, it is not applicable to the effect on power due to each source, because the power absorbed by a resistor depends on the square of the voltage or current. If the power value is needed, the current through (or voltage across) the element must be calculated first using superposition.

Other terms such as *killed*, *made inactive*, *deadened*, or *set equal to zero* are often used to convey the same idea.

Use the superposition theorem to find v in the circuit of Fig. 4.6.

Example 4.3

Solution:

Since there are two sources, let

$$v = v_1 + v_2$$

where v_1 and v_2 are the contributions due to the 6-V voltage source and the 3-A current source, respectively. To obtain v_1 , we set the current source to zero, as shown in Fig. 4.7(a). Applying KVL to the loop in Fig. 4.7(a) gives

$$12i_1 - 6 = 0 \quad \Rightarrow \quad i_1 = 0.5 \text{ A}$$

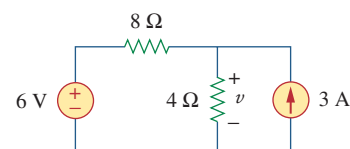
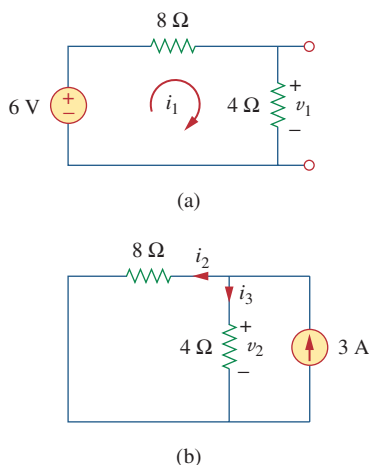

Figure 4.6
For Example 4.3.

**Figure 4.7**

For Example 4.3: (a) calculating v_1 ,
(b) calculating v_2 .

Thus,

$$v_1 = 4i_1 = 2 \text{ V}$$

We may also use voltage division to get v_1 by writing

$$v_1 = \frac{4}{4 + 8}(6) = 2 \text{ V}$$

To get v_2 , we set the voltage source to zero, as in Fig. 4.7(b). Using current division,

$$i_3 = \frac{8}{4 + 8}(3) = 2 \text{ A}$$

Hence,

$$v_2 = 4i_3 = 8 \text{ V}$$

And we find

$$v = v_1 + v_2 = 2 + 8 = 10 \text{ V}$$

Practice Problem 4.3

Using the superposition theorem, find v_o in the circuit of Fig. 4.8.

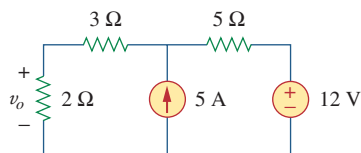
**Figure 4.8**

For Practice Prob. 4.3.

Answer: 7.4 V.

Example 4.4

Find i_o in the circuit of Fig. 4.9 using superposition.

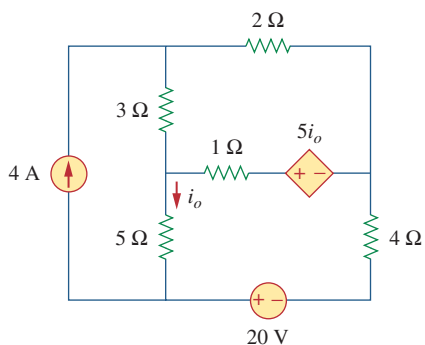
**Figure 4.9**

For Example 4.4.

Solution:

The circuit in Fig. 4.9 involves a dependent source, which must be left intact. We let

$$i_o = i'_o + i''_o \quad (4.4.1)$$

where i'_o and i''_o are due to the 4-A current source and 20-V voltage source respectively. To obtain i'_o , we turn off the 20-V source so that we have the circuit in Fig. 4.10(a). We apply mesh analysis in order to obtain i'_o . For loop 1,

$$i_1 = 4 \text{ A} \quad (4.4.2)$$

For loop 2,

$$-3i_1 + 6i_2 - 1i_3 - 5i'_o = 0 \quad (4.4.3)$$

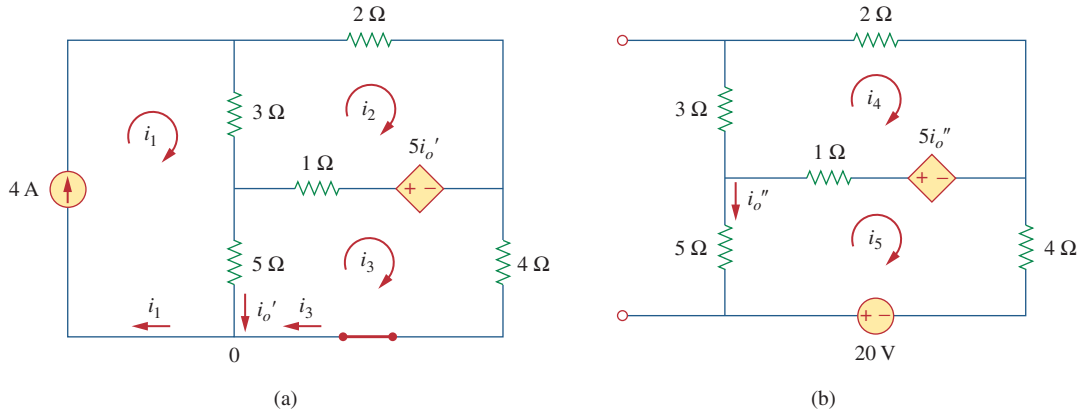
**Figure 4.10**

For Example 4.4: Applying superposition to (a) obtain i'_o , (b) obtain i''_o .

For loop 3,

$$-5i_1 - 1i_2 + 10i_3 + 5i'_o = 0 \quad (4.4.4)$$

But at node 0,

$$i_3 = i_1 - i'_o = 4 - i'_o \quad (4.4.5)$$

Substituting Eqs. (4.4.2) and (4.4.5) into Eqs. (4.4.3) and (4.4.4) gives two simultaneous equations

$$3i_2 - 2i'_o = 8 \quad (4.4.6)$$

$$i_2 + 5i'_o = 20 \quad (4.4.7)$$

which can be solved to get

$$i'_o = \frac{52}{17} \text{ A} \quad (4.4.8)$$

To obtain i''_o , we turn off the 4-A current source so that the circuit becomes that shown in Fig. 4.10(b). For loop 4, KVL gives

$$6i_4 - i_5 - 5i''_o = 0 \quad (4.4.9)$$

and for loop 5,

$$-i_4 + 10i_5 - 20 + 5i''_o = 0 \quad (4.4.10)$$

But $i_5 = -i''_o$. Substituting this in Eqs. (4.4.9) and (4.4.10) gives

$$6i_4 - 4i''_o = 0 \quad (4.4.11)$$

$$i_4 + 5i''_o = -20 \quad (4.4.12)$$

which we solve to get

$$i''_o = -\frac{60}{17} \text{ A} \quad (4.4.13)$$

Now substituting Eqs. (4.4.8) and (4.4.13) into Eq. (4.4.1) gives

$$i_o = -\frac{8}{17} = -0.4706 \text{ A}$$

Practice Problem 4.4

Use superposition to find v_x in the circuit of Fig. 4.11.

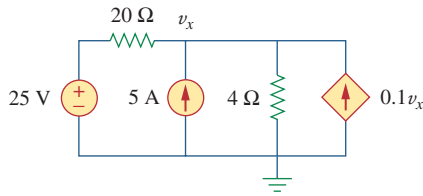

Figure 4.11

For Practice Prob. 4.4.

Answer: $v_x = 31.25$ V.

Example 4.5

For the circuit in Fig. 4.12, use the superposition theorem to find i .

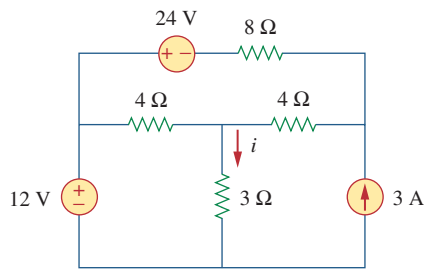

Figure 4.12

For Example 4.5.

Solution:

In this case, we have three sources. Let

$$i = i_1 + i_2 + i_3$$

where i_1 , i_2 , and i_3 are due to the 12-V, 24-V, and 3-A sources respectively. To get i_1 , consider the circuit in Fig. 4.13(a). Combining $4\ \Omega$ (on the right-hand side) in series with $8\ \Omega$ gives $12\ \Omega$. The $12\ \Omega$ in parallel with $4\ \Omega$ gives $12 \times 4/16 = 3\ \Omega$. Thus,

$$i_1 = \frac{12}{6} = 2\ \text{A}$$

To get i_2 , consider the circuit in Fig. 4.13(b). Applying mesh analysis gives

$$16i_a - 4i_b + 24 = 0 \quad \Rightarrow \quad 4i_a - i_b = -6 \quad (4.5.1)$$

$$7i_b - 4i_a = 0 \quad \Rightarrow \quad i_a = \frac{7}{4}i_b \quad (4.5.2)$$

Substituting Eq. (4.5.2) into Eq. (4.5.1) gives

$$i_2 = i_b = -1$$

To get i_3 , consider the circuit in Fig. 4.13(c). Using nodal analysis gives

$$3 = \frac{v_2}{8} + \frac{v_2 - v_1}{4} \quad \Rightarrow \quad 24 = 3v_2 - 2v_1 \quad (4.5.3)$$

$$\frac{v_2 - v_1}{4} = \frac{v_1}{4} + \frac{v_1}{3} \quad \Rightarrow \quad v_2 = \frac{10}{3}v_1 \quad (4.5.4)$$

Substituting Eq. (4.5.4) into Eq. (4.5.3) leads to $v_1 = 3$ and

$$i_3 = \frac{v_1}{3} = 1\ \text{A}$$

Thus,

$$i = i_1 + i_2 + i_3 = 2 - 1 + 1 = 2\ \text{A}$$

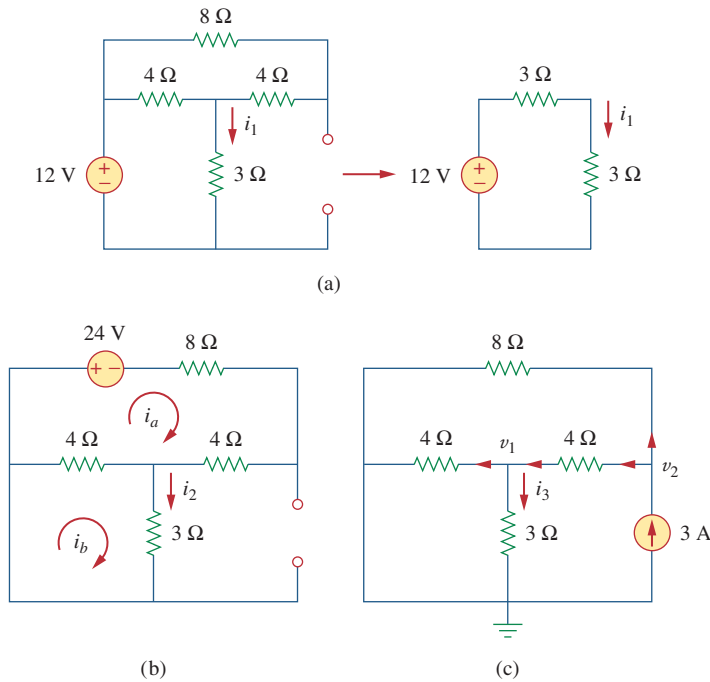

Figure 4.13
For Example 4.5.

Find I in the circuit of Fig. 4.14 using the superposition principle.

Practice Problem 4.5

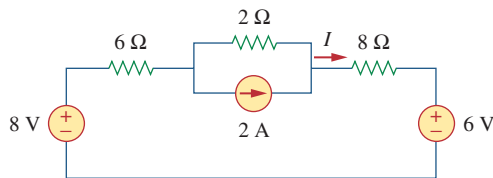

Figure 4.14
For Practice Prob. 4.5.

Answer: 375 mA.

4.4 Source Transformation

We have noticed that series-parallel combination and wye-delta transformation help simplify circuits. *Source transformation* is another tool for simplifying circuits. Basic to these tools is the concept of *equivalence*. We recall that an equivalent circuit is one whose v - i characteristics are identical with the original circuit.

In Section 3.6, we saw that node-voltage (or mesh-current) equations can be obtained by mere inspection of a circuit when the sources are all independent current (or all independent voltage) sources. It is therefore expedient in circuit analysis to be able to substitute a voltage source in series with a resistor for a current source in parallel with a