

Basic Concepts

Some books are to be tasted, others to be swallowed, and some few to be chewed and digested.

—Francis Bacon

Enhancing Your Skills and Your Career

ABET EC 2000 criteria (3.a), “an ability to apply knowledge of mathematics, science, and engineering.”

As students, you are required to study mathematics, science, and engineering with the purpose of being able to apply that knowledge to the solution of engineering problems. The skill here is the ability to apply the fundamentals of these areas in the solution of a problem. So how do you develop and enhance this skill?

The best approach is to work as many problems as possible in all of your courses. However, if you are really going to be successful with this, you must spend time analyzing where and when and why you have difficulty in easily arriving at successful solutions. You may be surprised to learn that most of your problem-solving problems are with mathematics rather than your understanding of theory. You may also learn that you start working the problem too soon. Taking time to think about the problem and how you should solve it will always save you time and frustration in the end.

What I have found that works best for me is to apply our six-step problem-solving technique. Then I carefully identify the areas where I have difficulty solving the problem. Many times, my actual deficiencies are in my understanding and ability to use correctly certain mathematical principles. I then return to my fundamental math texts and carefully review the appropriate sections, and in some cases, work some example problems in that text. This brings me to another important thing you should always do: Keep nearby all your basic mathematics, science, and engineering textbooks.

This process of continually looking up material you thought you had acquired in earlier courses may seem very tedious at first; however, as your skills develop and your knowledge increases, this process will become easier and easier. On a personal note, it is this very process that led me from being a much less than average student to someone who could earn a Ph.D. and become a successful researcher.



Photo by Charles Alexander

1.1 Introduction

Electric circuit theory and electromagnetic theory are the two fundamental theories upon which all branches of electrical engineering are built. Many branches of electrical engineering, such as power, electric machines, control, electronics, communications, and instrumentation, are based on electric circuit theory. Therefore, the basic electric circuit theory course is the most important course for an electrical engineering student, and always an excellent starting point for a beginning student in electrical engineering education. Circuit theory is also valuable to students specializing in other branches of the physical sciences because circuits are a good model for the study of energy systems in general, and because of the applied mathematics, physics, and topology involved.

In electrical engineering, we are often interested in communicating or transferring energy from one point to another. To do this requires an interconnection of electrical devices. Such interconnection is referred to as an *electric circuit*, and each component of the circuit is known as an *element*.

An **electric circuit** is an interconnection of electrical elements.

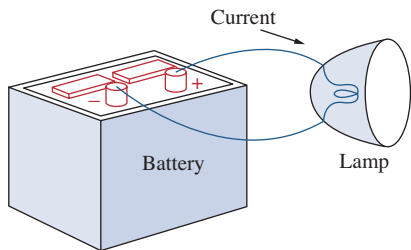

Figure 1.1
A simple electric circuit.

A simple electric circuit is shown in Fig. 1.1. It consists of three basic elements: a battery, a lamp, and connecting wires. Such a simple circuit can exist by itself; it has several applications, such as a flashlight, a search light, and so forth.

A complicated real circuit is displayed in Fig. 1.2, representing the schematic diagram for a radio receiver. Although it seems complicated, this circuit can be analyzed using the techniques we cover in this book. Our goal in this text is to learn various analytical techniques and computer software applications for describing the behavior of a circuit like this.

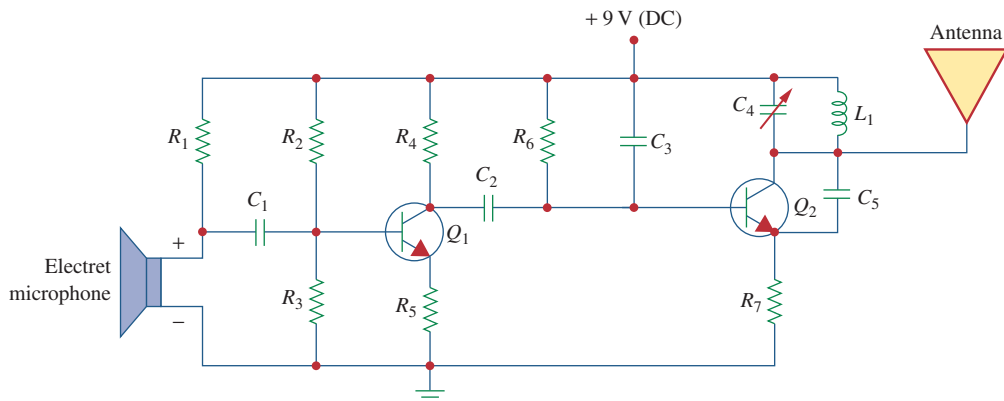

Figure 1.2
Electric circuit of a radio transmitter.

Electric circuits are used in numerous electrical systems to accomplish different tasks. Our objective in this book is not the study of various uses and applications of circuits. Rather, our major concern is the analysis of the circuits. By the analysis of a circuit, we mean a study of the behavior of the circuit: How does it respond to a given input? How do the interconnected elements and devices in the circuit interact?

We commence our study by defining some basic concepts. These concepts include charge, current, voltage, circuit elements, power, and energy. Before defining these concepts, we must first establish a system of units that we will use throughout the text.

1.2 Systems of Units

As electrical engineers, we deal with measurable quantities. Our measurement, however, must be communicated in a standard language that virtually all professionals can understand, irrespective of the country where the measurement is conducted. Such an international measurement language is the International System of Units (SI), adopted by the General Conference on Weights and Measures in 1960. In this system, there are seven principal units from which the units of all other physical quantities can be derived. Table 1.1 shows the six units and one derived unit that are relevant to this text. The SI units are used throughout this text.

One great advantage of the SI unit is that it uses prefixes based on the power of 10 to relate larger and smaller units to the basic unit. Table 1.2 shows the SI prefixes and their symbols. For example, the following are expressions of the same distance in meters (m):

$$600,000,000 \text{ mm} \quad 600,000 \text{ m} \quad 600 \text{ km}$$

1.3 Charge and Current

The concept of electric charge is the underlying principle for explaining all electrical phenomena. Also, the most basic quantity in an electric circuit is the *electric charge*. We all experience the effect of electric

TABLE 1.1

Six basic SI units and one derived unit relevant to this text.

Quantity	Basic unit	Symbol
Length	meter	m
Mass	kilogram	kg
Time	second	s
Electric current	ampere	A
Thermodynamic temperature	kelvin	K
Luminous intensity	candela	cd
Charge	coulomb	C

TABLE 1.2

The SI prefixes.

Multiplier	Prefix	Symbol
10^{18}	exa	E
10^{15}	peta	P
10^{12}	tera	T
10^9	giga	G
10^6	mega	M
10^3	kilo	k
10^2	hecto	h
10	deka	da
10^{-1}	deci	d
10^{-2}	centi	c
10^{-3}	milli	m
10^{-6}	micro	μ
10^{-9}	nano	n
10^{-12}	pico	p
10^{-15}	femto	f
10^{-18}	atto	a

charge when we try to remove our wool sweater and have it stick to our body or walk across a carpet and receive a shock.

Charge is an electrical property of the atomic particles of which matter consists, measured in coulombs (C).

We know from elementary physics that all matter is made of fundamental building blocks known as atoms and that each atom consists of electrons, protons, and neutrons. We also know that the charge e on an electron is negative and equal in magnitude to 1.602×10^{-19} C, while a proton carries a positive charge of the same magnitude as the electron. The presence of equal numbers of protons and electrons leaves an atom neutrally charged.

The following points should be noted about electric charge:

1. The coulomb is a large unit for charges. In 1 C of charge, there are $1/(1.602 \times 10^{-19}) = 6.24 \times 10^{18}$ electrons. Thus realistic or laboratory values of charges are on the order of pC, nC, or μC .¹
2. According to experimental observations, the only charges that occur in nature are integral multiples of the electronic charge $e = -1.602 \times 10^{-19}$ C.
3. The *law of conservation of charge* states that charge can neither be created nor destroyed, only transferred. Thus the algebraic sum of the electric charges in a system does not change.

We now consider the flow of electric charges. A unique feature of electric charge or electricity is the fact that it is mobile; that is, it can be transferred from one place to another, where it can be converted to another form of energy.

When a conducting wire (consisting of several atoms) is connected to a battery (a source of electromotive force), the charges are compelled to move; positive charges move in one direction while negative charges move in the opposite direction. This motion of charges creates electric current. It is conventional to take the current flow as the movement of positive charges. That is, opposite to the flow of negative charges, as Fig. 1.3 illustrates. This convention was introduced by Benjamin Franklin (1706–1790), the American scientist and inventor. Although we now know that current in metallic conductors is due to negatively charged electrons, we will follow the universally accepted convention that current is the net flow of positive charges. Thus,

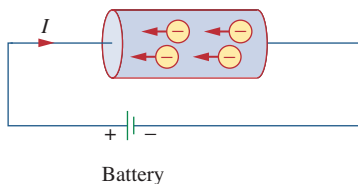

Figure 1.3

Electric current due to flow of electronic charge in a conductor.

A convention is a standard way of describing something so that others in the profession can understand what we mean. We will be using IEEE conventions throughout this book.

Electric current is the time rate of change of charge, measured in amperes (A).

Mathematically, the relationship between current i , charge q , and time t is

$$i \triangleq \frac{dq}{dt} \quad (1.1)$$

¹ However, a large power supply capacitor can store up to 0.5 C of charge.

Historical

Andre-Marie Ampere (1775–1836), a French mathematician and physicist, laid the foundation of electrodynamics. He defined the electric current and developed a way to measure it in the 1820s.

Born in Lyons, France, Ampere at age 12 mastered Latin in a few weeks, as he was intensely interested in mathematics and many of the best mathematical works were in Latin. He was a brilliant scientist and a prolific writer. He formulated the laws of electromagnetics. He invented the electromagnet and the ammeter. The unit of electric current, the ampere, was named after him.



The Burndy Library Collection
at The Huntington Library,
San Marino, California.

where current is measured in amperes (A), and

$$1 \text{ ampere} = 1 \text{ coulomb/second}$$

The charge transferred between time t_0 and t is obtained by integrating both sides of Eq. (1.1). We obtain

$$Q \triangleq \int_{t_0}^t i \, dt \quad (1.2)$$

The way we define current as i in Eq. (1.1) suggests that current need not be a constant-valued function. As many of the examples and problems in this chapter and subsequent chapters suggest, there can be several types of current; that is, charge can vary with time in several ways.

If the current does not change with time, but remains constant, we call it a *direct current* (dc).

A **direct current** (dc) is a current that remains constant with time.

By convention the symbol I is used to represent such a constant current.

A time-varying current is represented by the symbol i . A common form of time-varying current is the sinusoidal current or *alternating current* (ac).

An **alternating current** (ac) is a current that varies sinusoidally with time.

Such current is used in your household to run the air conditioner, refrigerator, washing machine, and other electric appliances. Figure 1.4

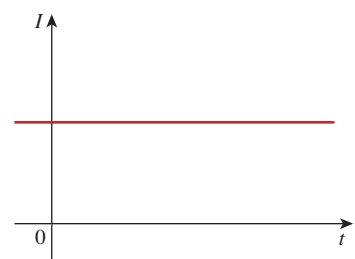

(a)

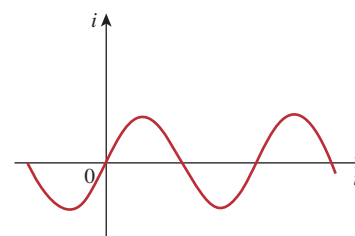

(b)

Figure 1.4

Two common types of current: (a) direct current (dc), (b) alternating current (ac).

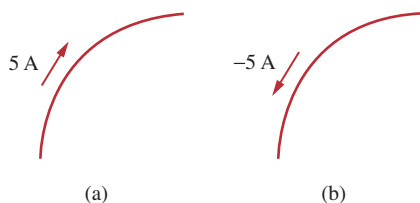
**Figure 1.5**

Conventional current flow: (a) positive current flow, (b) negative current flow.

shows direct current and alternating current; these are the two most common types of current. We will consider other types later in the book.

Once we define current as the movement of charge, we expect current to have an associated direction of flow. As mentioned earlier, the direction of current flow is conventionally taken as the direction of positive charge movement. Based on this convention, a current of 5 A may be represented positively or negatively as shown in Fig. 1.5. In other words, a negative current of -5 A flowing in one direction as shown in Fig. 1.5(b) is the same as a current of $+5$ A flowing in the opposite direction.

Example 1.1

How much charge is represented by 4,600 electrons?

Solution:

Each electron has -1.602×10^{-19} C. Hence 4,600 electrons will have -1.602×10^{-19} C/electron \times 4,600 electrons = -7.369×10^{-16} C

Practice Problem 1.1

Calculate the amount of charge represented by six million protons.

Answer: $+9.612 \times 10^{-13}$ C.

Example 1.2

The total charge entering a terminal is given by $q = 5t \sin 4\pi t$ mC. Calculate the current at $t = 0.5$ s.

Solution:

$$i = \frac{dq}{dt} = \frac{d}{dt}(5t \sin 4\pi t) \text{ mC/s} = (5 \sin 4\pi t + 20\pi t \cos 4\pi t) \text{ mA}$$

At $t = 0.5$,

$$i = 5 \sin 2\pi + 10\pi \cos 2\pi = 0 + 10\pi = 31.42 \text{ mA}$$

Practice Problem 1.2

If in Example 1.2, $q = (10 - 10e^{-2t})$ mC, find the current at $t = 1.0$ s.

Answer: 2.707 mA.

Determine the total charge entering a terminal between $t = 1$ s and $t = 2$ s if the current passing the terminal is $i = (3t^2 - t)$ A.

Example 1.3

Solution:

$$\begin{aligned} Q &= \int_{t=1}^2 i \, dt = \int_1^2 (3t^2 - t) \, dt \\ &= \left(t^3 - \frac{t^2}{2} \right) \Big|_1^2 = (8 - 2) - \left(1 - \frac{1}{2} \right) = 5.5 \text{ C} \end{aligned}$$

The current flowing through an element is

Practice Problem 1.3

$$i = \begin{cases} 4 \text{ A}, & 0 < t < 1 \\ 4t^2 \text{ A}, & t > 1 \end{cases}$$

Calculate the charge entering the element from $t = 0$ to $t = 2$ s.

Answer: 13.333 C.

1.4 Voltage

As explained briefly in the previous section, to move the electron in a conductor in a particular direction requires some work or energy transfer. This work is performed by an external electromotive force (emf), typically represented by the battery in Fig. 1.3. This emf is also known as *voltage* or *potential difference*. The voltage v_{ab} between two points a and b in an electric circuit is the energy (or work) needed to move a unit charge from a to b ; mathematically,

$$v_{ab} \triangleq \frac{dw}{dq} \quad (1.3)$$

where w is energy in joules (J) and q is charge in coulombs (C). The voltage v_{ab} or simply v is measured in volts (V), named in honor of the Italian physicist Alessandro Antonio Volta (1745–1827), who invented the first voltaic battery. From Eq. (1.3), it is evident that

$$1 \text{ volt} = 1 \text{ joule/coulomb} = 1 \text{ newton-meter/coulomb}$$

Thus,

Voltage (or **potential difference**) is the energy required to move a unit charge through an element, measured in volts (V).

Figure 1.6 shows the voltage across an element (represented by a rectangular block) connected to points a and b . The plus (+) and minus (−) signs are used to define reference direction or voltage polarity. The v_{ab} can be interpreted in two ways: (1) Point a is at a potential of v_{ab}

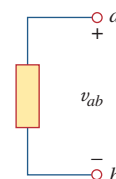

Figure 1.6
Polarity of voltage v_{ab} .

Historical



The Burndy Library Collection
at The Huntington Library,
San Marino, California.

Alessandro Antonio Volta (1745–1827), an Italian physicist, invented the electric battery—which provided the first continuous flow of electricity—and the capacitor.

Born into a noble family in Como, Italy, Volta was performing electrical experiments at age 18. His invention of the battery in 1796 revolutionized the use of electricity. The publication of his work in 1800 marked the beginning of electric circuit theory. Volta received many honors during his lifetime. The unit of voltage or potential difference, the volt, was named in his honor.

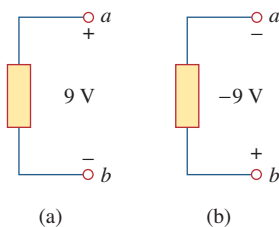

Figure 1.7

Two equivalent representations of the same voltage v_{ab} : (a) Point a is 9 V above point b ; (b) point b is -9 V above point a .

Keep in mind that electric current is always *through* an element and that electric voltage is always *across* the element or between two points.

volts higher than point b , or (2) the potential at point a with respect to point b is v_{ab} . It follows logically that in general

$$v_{ab} = -v_{ba} \quad (1.4)$$

For example, in Fig. 1.7, we have two representations of the same voltage. In Fig. 1.7(a), point a is +9 V above point b ; in Fig. 1.7(b), point b is -9 V above point a . We may say that in Fig. 1.7(a), there is a 9-V *voltage drop* from a to b or equivalently a 9-V *voltage rise* from b to a . In other words, a voltage drop from a to b is equivalent to a voltage rise from b to a .

Current and voltage are the two basic variables in electric circuits. The common term *signal* is used for an electric quantity such as a current or a voltage (or even electromagnetic wave) when it is used for conveying information. Engineers prefer to call such variables signals rather than mathematical functions of time because of their importance in communications and other disciplines. Like electric current, a constant voltage is called a *dc voltage* and is represented by V , whereas a sinusoidally time-varying voltage is called an *ac voltage* and is represented by v . A dc voltage is commonly produced by a battery; ac voltage is produced by an electric generator.

1.5 Power and Energy

Although current and voltage are the two basic variables in an electric circuit, they are not sufficient by themselves. For practical purposes, we need to know how much *power* an electric device can handle. We all know from experience that a 100-watt bulb gives more light than a 60-watt bulb. We also know that when we pay our bills to the electric utility companies, we are paying for the electric *energy* consumed over a certain period of time. Thus, power and energy calculations are important in circuit analysis.

To relate power and energy to voltage and current, we recall from physics that:

Power is the time rate of expending or absorbing energy, measured in watts (W).

We write this relationship as

$$p \triangleq \frac{dw}{dt} \quad (1.5)$$

where p is power in watts (W), w is energy in joules (J), and t is time in seconds (s). From Eqs. (1.1), (1.3), and (1.5), it follows that

$$p = \frac{dw}{dt} = \frac{dw}{dq} \cdot \frac{dq}{dt} = vi \quad (1.6)$$

or

$$p = vi \quad (1.7)$$

The power p in Eq. (1.7) is a time-varying quantity and is called the *instantaneous power*. Thus, the power absorbed or supplied by an element is the product of the voltage across the element and the current through it. If the power has a + sign, power is being delivered to or absorbed by the element. If, on the other hand, the power has a – sign, power is being supplied by the element. But how do we know when the power has a negative or a positive sign?

Current direction and voltage polarity play a major role in determining the sign of power. It is therefore important that we pay attention to the relationship between current i and voltage v in Fig. 1.8(a). The voltage polarity and current direction must conform with those shown in Fig. 1.8(a) in order for the power to have a positive sign. This is known as the *passive sign convention*. By the passive sign convention, current enters through the positive polarity of the voltage. In this case, $p = +vi$ or $vi > 0$ implies that the element is absorbing power. However, if $p = -vi$ or $vi < 0$, as in Fig. 1.8(b), the element is releasing or supplying power.

Passive sign convention is satisfied when the current enters through the positive terminal of an element and $p = +vi$. If the current enters through the negative terminal, $p = -vi$.

Unless otherwise stated, we will follow the passive sign convention throughout this text. For example, the element in both circuits of Fig. 1.9 has an absorbing power of +12 W because a positive current enters the positive terminal in both cases. In Fig. 1.10, however, the element is supplying power of +12 W because a positive current enters the negative terminal. Of course, an absorbing power of –12 W is equivalent to a supplying power of +12 W. In general,

$$+\text{Power absorbed} = -\text{Power supplied}$$

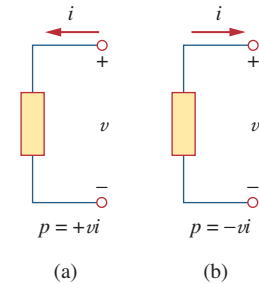

Figure 1.8

Reference polarities for power using the passive sign convention: (a) absorbing power, (b) supplying power.

When the voltage and current directions conform to Fig. 1.8(b), we have the *active sign convention* and $p = +vi$.

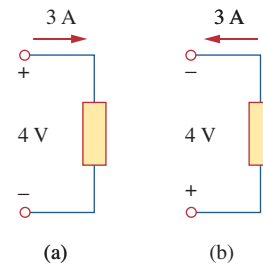

Figure 1.9

Two cases of an element with an absorbing power of 12 W: (a) $p = 4 \times 3 = 12$ W, (b) $p = 4 \times 3 = 12$ W.

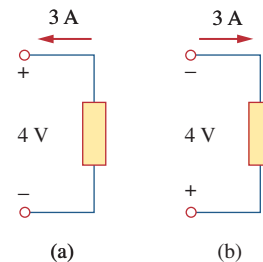

Figure 1.10

Two cases of an element with a supplying power of 12 W: (a) $p = -4 \times 3 = -12$ W, (b) $p = -4 \times 3 = -12$ W.

In fact, the *law of conservation of energy* must be obeyed in any electric circuit. For this reason, the algebraic sum of power in a circuit, at any instant of time, must be zero:

$$\sum p = 0 \quad (1.8)$$

This again confirms the fact that the total power supplied to the circuit must balance the total power absorbed.

From Eq. (1.6), the energy absorbed or supplied by an element from time t_0 to time t is

$$w = \int_{t_0}^t p \, dt = \int_{t_0}^t vi \, dt \quad (1.9)$$

Energy is the capacity to do work, measured in joules (J).

The electric power utility companies measure energy in watt-hours (Wh), where

$$1 \text{ Wh} = 3,600 \text{ J}$$

Example 1.4

An energy source forces a constant current of 2 A for 10 s to flow through a light bulb. If 2.3 kJ is given off in the form of light and heat energy, calculate the voltage drop across the bulb.

Solution:

The total charge is

$$\Delta q = i \Delta t = 2 \times 10 = 20 \text{ C}$$

The voltage drop is

$$v = \frac{\Delta w}{\Delta q} = \frac{2.3 \times 10^3}{20} = 115 \text{ V}$$

Practice Problem 1.4

To move charge q from point a to point b requires -30 J. Find the voltage drop v_{ab} if: (a) $q = 6$ C, (b) $q = -3$ C.

Answer: (a) -5 V, (b) 10 V.

Example 1.5

Find the power delivered to an element at $t = 3$ ms if the current entering its positive terminal is

$$i = 5 \cos 60\pi t \text{ A}$$

and the voltage is: (a) $v = 3i$, (b) $v = 3 \, di/dt$.

Solution:

(a) The voltage is $v = 3i = 15 \cos 60\pi t$; hence, the power is

$$p = vi = 75 \cos^2 60\pi t \text{ W}$$

At $t = 3$ ms,

$$p = 75 \cos^2 (60\pi \times 3 \times 10^{-3}) = 75 \cos^2 0.18\pi = 53.48 \text{ W}$$

(b) We find the voltage and the power as

$$v = 3 \frac{di}{dt} = 3(-60\pi)5 \sin 60\pi t = -900\pi \sin 60\pi t \text{ V}$$

$$p = vi = -4500\pi \sin 60\pi t \cos 60\pi t \text{ W}$$

At $t = 3$ ms,

$$\begin{aligned} p &= -4500\pi \sin 0.18\pi \cos 0.18\pi \text{ W} \\ &= -14137.167 \sin 32.4^\circ \cos 32.4^\circ = -6.396 \text{ kW} \end{aligned}$$

Find the power delivered to the element in Example 1.5 at $t = 5$ ms if the current remains the same but the voltage is: (a) $v = 2i$ V,

(b) $v = \left(10 + 5 \int_0^t i \, dt \right)$ V.

Practice Problem 1.5

Answer: (a) 17.27 W, (b) 29.7 W.

How much energy does a 100-W electric bulb consume in two hours?

Example 1.6**Solution:**

$$\begin{aligned} w &= pt = 100 \text{ (W)} \times 2 \text{ (h)} \times 60 \text{ (min/h)} \times 60 \text{ (s/min)} \\ &= 720,000 \text{ J} = 720 \text{ kJ} \end{aligned}$$

This is the same as

$$w = pt = 100 \text{ W} \times 2 \text{ h} = 200 \text{ Wh}$$

A stove element draws 15 A when connected to a 240-V line. How long does it take to consume 180 kJ?

Practice Problem 1.6

Answer: 50 s.

Historical

1884 Exhibition In the United States, nothing promoted the future of electricity like the 1884 International Electrical Exhibition. Just imagine a world without electricity, a world illuminated by candles and gaslights, a world where the most common transportation was by walking and riding on horseback or by horse-drawn carriage. Into this world an exhibition was created that highlighted Thomas Edison and reflected his highly developed ability to promote his inventions and products. His exhibit featured spectacular lighting displays powered by an impressive 100-kW “Jumbo” generator.

Edward Weston’s dynamos and lamps were featured in the United States Electric Lighting Company’s display. Weston’s well known collection of scientific instruments was also shown.

Other prominent exhibitors included Frank Sprague, Elihu Thompson, and the Brush Electric Company of Cleveland. The American Institute of Electrical Engineers (AIEE) held its first technical meeting on October 7–8 at the Franklin Institute during the exhibit. AIEE merged with the Institute of Radio Engineers (IRE) in 1964 to form the Institute of Electrical and Electronics Engineers (IEEE).

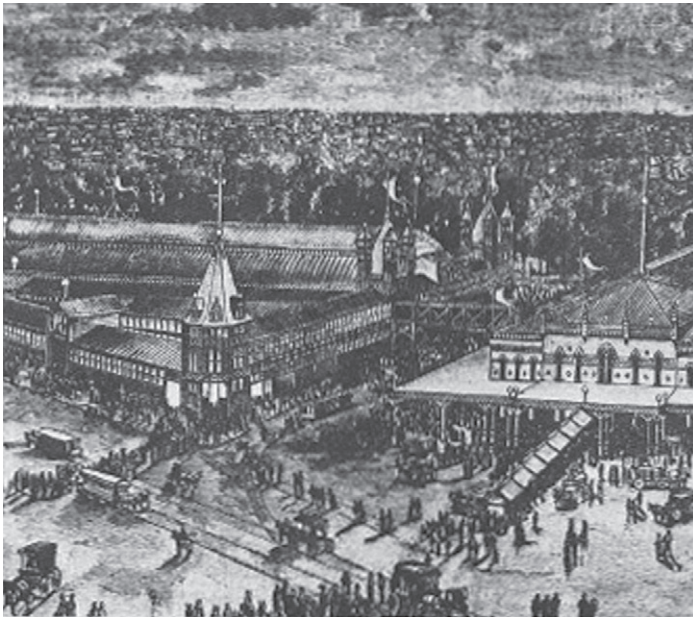

Smithsonian Institution.



1.6 Circuit Elements

As we discussed in Section 1.1, an element is the basic building block of a circuit. An electric circuit is simply an interconnection of the elements. Circuit analysis is the process of determining voltages across (or the currents through) the elements of the circuit.

There are two types of elements found in electric circuits: *passive* elements and *active* elements. An active element is capable of generating energy while a passive element is not. Examples of passive elements are resistors, capacitors, and inductors. Typical active elements include generators, batteries, and operational amplifiers. Our aim in this section is to gain familiarity with some important active elements.

The most important active elements are voltage or current sources that generally deliver power to the circuit connected to them. There are two kinds of sources: independent and dependent sources.

An **ideal independent source** is an active element that provides a specified voltage or current that is completely independent of other circuit elements.

In other words, an ideal independent voltage source delivers to the circuit whatever current is necessary to maintain its terminal voltage. Physical sources such as batteries and generators may be regarded as approximations to ideal voltage sources. Figure 1.11 shows the symbols for independent voltage sources. Notice that both symbols in Fig. 1.11(a) and (b) can be used to represent a dc voltage source, but only the symbol in Fig. 1.11(a) can be used for a time-varying voltage source. Similarly, an ideal independent current source is an active element that provides a specified current completely independent of the voltage across the source. That is, the current source delivers to the circuit whatever voltage is necessary to maintain the designated current. The symbol for an independent current source is displayed in Fig. 1.12, where the arrow indicates the direction of current i .

An **ideal dependent** (or **controlled**) **source** is an active element in which the source quantity is controlled by another voltage or current.

Dependent sources are usually designated by diamond-shaped symbols, as shown in Fig. 1.13. Since the control of the dependent source is achieved by a voltage or current of some other element in the circuit, and the source can be voltage or current, it follows that there are four possible types of dependent sources, namely:

1. A voltage-controlled voltage source (VCVS).
2. A current-controlled voltage source (CCVS).
3. A voltage-controlled current source (VCCS).
4. A current-controlled current source (CCCS).

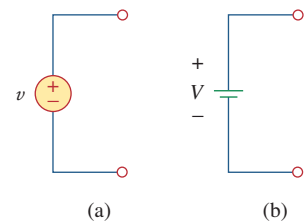

Figure 1.11

Symbols for independent voltage sources: (a) used for constant or time-varying voltage, (b) used for constant voltage (dc).

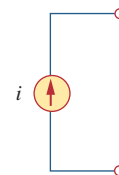

Figure 1.12

Symbol for independent current source.

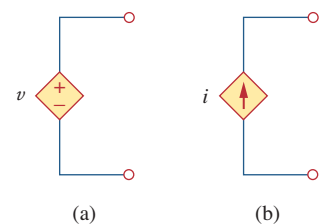

Figure 1.13

Symbols for: (a) dependent voltage source, (b) dependent current source.

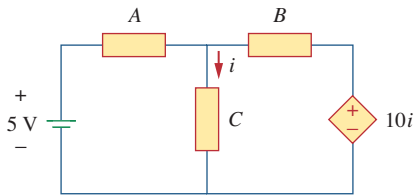

Figure 1.14

The source on the right-hand side is a current-controlled voltage source.

Dependent sources are useful in modeling elements such as transistors, operational amplifiers, and integrated circuits. An example of a current-controlled voltage source is shown on the right-hand side of Fig. 1.14, where the voltage $10i$ of the voltage source depends on the current i through element C . Students might be surprised that the value of the dependent voltage source is $10i$ V (and not $10i$ A) because it is a voltage source. The key idea to keep in mind is that a voltage source comes with polarities (+ -) in its symbol, while a current source comes with an arrow, irrespective of what it depends on.

It should be noted that an ideal voltage source (dependent or independent) will produce any current required to ensure that the terminal voltage is as stated, whereas an ideal current source will produce the necessary voltage to ensure the stated current flow. Thus, an ideal source could in theory supply an infinite amount of energy. It should also be noted that not only do sources supply power to a circuit, they can absorb power from a circuit too. For a voltage source, we know the voltage but not the current supplied or drawn by it. By the same token, we know the current supplied by a current source but not the voltage across it.

Example 1.7

Calculate the power supplied or absorbed by each element in Fig. 1.15.

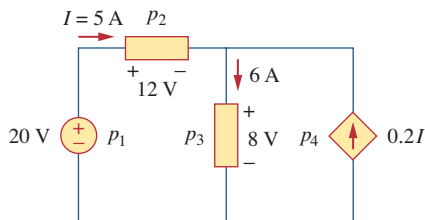

Figure 1.15

For Example 1.7.

Solution:

We apply the sign convention for power shown in Figs. 1.8 and 1.9. For p_1 , the 5-A current is out of the positive terminal (or into the negative terminal); hence,

$$p_1 = 20(-5) = -100 \text{ W} \quad \text{Supplied power}$$

For p_2 and p_3 , the current flows into the positive terminal of the element in each case.

$$p_2 = 12(5) = 60 \text{ W} \quad \text{Absorbed power}$$

$$p_3 = 8(6) = 48 \text{ W} \quad \text{Absorbed power}$$

For p_4 , we should note that the voltage is 8 V (positive at the top), the same as the voltage for p_3 , since both the passive element and the dependent source are connected to the same terminals. (Remember that voltage is always measured across an element in a circuit.) Since the current flows out of the positive terminal,

$$p_4 = 8(-0.2I) = 8(-0.2 \times 5) = -8 \text{ W} \quad \text{Supplied power}$$

We should observe that the 20-V independent voltage source and 0.2I dependent current source are supplying power to the rest of the network, while the two passive elements are absorbing power. Also,

$$p_1 + p_2 + p_3 + p_4 = -100 + 60 + 48 - 8 = 0$$

In agreement with Eq. (1.8), the total power supplied equals the total power absorbed.

Compute the power absorbed or supplied by each component of the circuit in Fig. 1.16.

Answer: $p_1 = -45 \text{ W}$, $p_2 = 18 \text{ W}$, $p_3 = 12 \text{ W}$, $p_4 = 15 \text{ W}$.

1.7 † Applications²

In this section, we will consider two practical applications of the concepts developed in this chapter. The first one deals with the TV picture tube and the other with how electric utilities determine your electric bill.

1.7.1 TV Picture Tube

One important application of the motion of electrons is found in both the transmission and reception of TV signals. At the transmission end, a TV camera reduces a scene from an optical image to an electrical signal. Scanning is accomplished with a thin beam of electrons in an iconoscope camera tube.

At the receiving end, the image is reconstructed by using a cathode-ray tube (CRT) located in the TV receiver.³ The CRT is depicted in Fig. 1.17. Unlike the iconoscope tube, which produces an electron beam of constant intensity, the CRT beam varies in intensity according to the incoming signal. The electron gun, maintained at a high potential, fires the electron beam. The beam passes through two sets of plates for vertical and horizontal deflections so that the spot on the screen where the beam strikes can move right and left and up and down. When the electron beam strikes the fluorescent screen, it gives off light at that spot. Thus, the beam can be made to “paint” a picture on the TV screen.

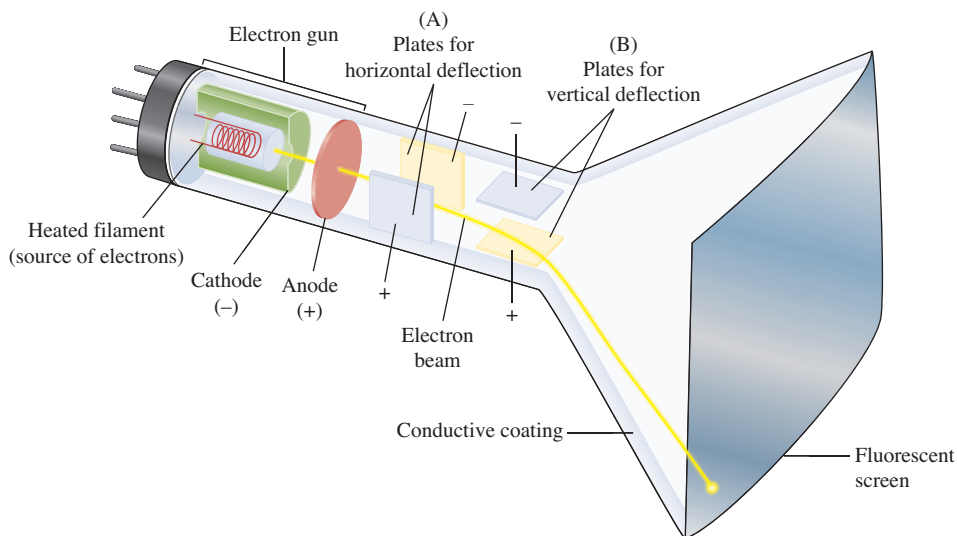

Figure 1.17
Cathode-ray tube.

Practice Problem 1.7

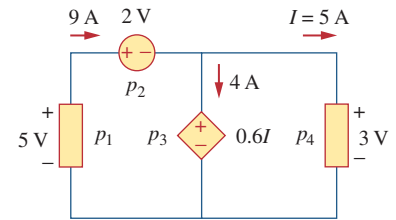

Figure 1.16
For Practice Prob. 1.7.

² The dagger sign preceding a section heading indicates the section that may be skipped, explained briefly, or assigned as homework.

³ Modern TV tubes use a different technology.