



CIMMYT

WHEAT PROGRAM

**Practical Guide
to the Identification
of Selected Diseases
of Wheat and
Barley**



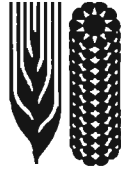

CIMMYT

WHEAT PROGRAM

**Practical Guide
to the Identification
of Selected Diseases
of Wheat and
Barley**

L. Gilchrist-Saavedra, G. Fuentes-Dávila
and C. Martínez-Cano

CIMMYT is an internationally funded, nonprofit scientific research and training organization. Headquartered in Mexico, the Center works with agricultural research institutions worldwide to improve the productivity and sustainability of maize and wheat systems for poor farmers in developing countries. It is one of 16 similar centers supported by the Consultative Group on International Agricultural Research (CGIAR). The CGIAR comprises over 50 partner countries, international and regional organizations, and private foundations. It is co-sponsored by the Food and Agriculture Organization (FAO) of the United Nations, the International Bank for Reconstruction and Development (World Bank), the United Nations Development Programme (UNDP), and the United Nations Environment Programme (UNEP).

Financial support for CIMMYT's research agenda currently comes from many sources, including the governments of Australia, Austria, Belgium, Canada, China, Denmark, France, Germany, India, Iran, Italy, Japan, the Republic of Korea, Mexico, the Netherlands, Norway, the Philippines, Spain, Switzerland, the United Kingdom, and the USA, and from the European Union, the Ford Foundation, the Inter-American Development Bank, the Kellogg Foundation, the OPEC Fund for International Development, the Rockefeller Foundation, the Sasakawa Africa Association, UNDP, and the World Bank.

Responsibility for this publication rests solely with CIMMYT.

Correct citation: Gilchrist-Saavedra, L., G. Fuentes-Dávila, and C. Martínez-Cano. 1997. Practical Guide to the Identification of Selected Diseases of Wheat and Barley. Mexico, D.F.: CIMMYT.

ISBN: 968-6923-82-9

AGROVOC descriptors: Wheats; Barley; Plant diseases; Bacterioses; Fungal diseases; Viroses; Nematoda; Identification; Methods.

AGRIS category codes: H20

Dewey decimal classification: 633.1193

Edited by: Alma McNab

Design and layout: Juan J. Joven, Eliot Sánchez P. and Marcelo Ortiz S. Printed in Mexico.

Table of Contents

Preface	vi
CHAPTER 1. GENERAL OVERVIEW	
Collecting samples	1
Preserving samples	1
Basic requirements of a plant pathology lab	3
Basic equipment	3
Maintaining a microbe-free environment	5
Sterilization	6
Disinfection	7
Culture media	7
Types of media	7
Deciding which culture media to use	8
Lab practice	8
Media preparation	8
How to prepare moist chambers	16
Preparing specimens for observation under the microscope	17
Determining inoculum concentration	19
Greenhouse inoculation	21
CHAPTER 2. BASIDIOMYCETES	
Introduction	24
The rusts	24
Monitoring the leaf rust population	25
Questions	28
Smuts and bunts	28
Identifying loose smut and Karnal bunt	29
Inoculation methods	29
CHAPTER 3. ASCOMYCETES	
Introduction	31
Identification of spot blotch caused by <i>Helminthosporium sativum</i>	31
Symptoms and isolation of the fungus	32
Identification of tan spot caused by <i>Helminthosporium tritici-repentis</i>	32
Symptoms and isolation of the fungus	33
Identification of <i>Helminthosporium</i> spp., causal agents of barley net and spot blotch	33
Symptoms and isolation of the fungus	33
Identification of leaf blotch caused by <i>Mycosphaerella graminicola</i> (<i>Septoria tritici</i>) and glume blotch caused by <i>Leptosphaeria nodorum</i> (<i>Septoria nodorum</i>)	34
Symptoms and isolation of the fungus	34

Identification of head scab of wheat caused by <i>Fusarium</i> spp.	35
Symptoms and isolation of the fungus	35
Inoculum preparation and field inoculation	35
CHAPTER 4. DEUTEROMYCETES	
Introduction	37
Identification of black point caused by <i>Alternaria alternata</i>, <i>A. triticina</i> and/or <i>Helminthosporium sativum</i>	37
Symptoms and isolation of the pathogen	37
Identification of <i>Rhynchosporium secalis</i>, causal agent of barley scald	37
Symptoms and isolation of the pathogen	38
CHAPTER 5. SOIL, CROWN AND ROOT PATHOGENS	
Introduction	40
Symptoms caused by <i>Fusarium</i> and <i>Helminthosporium</i>	40
Symptoms and isolation of <i>Fusarium</i>	40
Isolation and identification of <i>Helminthosporium</i>	43
Symptoms of <i>Pythium</i>, <i>Gaeumannomyces</i> and <i>Rhizoctonia</i>	44
<i>Pythium</i>	44
<i>Gaeumannomyces graminis</i> var. <i>tritici</i> (syn. <i>Ophiobolus graminis</i>), take-all	44
<i>Rhizoctonia</i>	45
Isolation of <i>Pythium</i>, <i>Gaeumannomyces</i> and <i>Rhizoctonia</i>	45
Identification of <i>Pythium</i>	47
Method for inducing zoospore production	48
Identification of <i>Gaeumannomyces</i>	48
Identification of <i>Rhizoctonia</i>	48
Identification of <i>Sclerotium rolfsii</i>	48
CHAPTER 6. NEMATODES	
Introduction	49
Soil nematodes: Identification of parasitic and saprophytic species	49
Sampling techniques	49
Methods for isolating nematodes from soil and plant tissue samples	51
Comparing two methods for isolating nematodes from soil and plant tissue	52
Identification of <i>Meloidogyne</i> species	52
Preparing perineal patterns of <i>Meloidogyne</i> females	52

CHAPTER 7. BACTERIAL DISEASES

Introduction	54
Identifying a bacterial disease	54
Pathogenicity test	56
Biochemical and physiological tests	57

CHAPTER 8. VIRUSES

Introduction	60
Barley yellow dwarf virus	60
Identification of BYDV aphid vectors	61
BYDV transmission	61
Barley stripe mosaic virus	62
BSMV transmission	62
Detecting seed transmission of the virus	63
Appendix	64

Preface

This practical guide is intended for use in identifying some wheat and barley diseases and their causal agents. It can also help readers learn to handle those pathogens in labs, in the field, and in greenhouses. The guide is not intended to be a comprehensive treatise on wheat and barley pathogens. Instead it targets the most important pathogens that affect small grain cereals in developing countries, since economic losses in those countries are more significant than in other cereal-producing areas of the world.

The guide is intended for researchers working on plant pathology in support of small grain cereal improvement programs aimed at generating disease-resistant germplasm. However, it should also be useful for technicians and extension workers who do not have a plant pathologist to help them identify diseases.

The authors wish to thank Drs. Etienne Duveiller, Dennis A. Lawn and Monica Mezzalama for their contribution to the bacteria, nematode, and virus chapters, respectively. Also, the authors wish to thank Dr. Jesse Dubin for reviewing the manuscript; Alma McNab for editing it; Marta Larios for typing the information; Ana Maria Sanchez for taking the photographs; and Miguel Mellado and Eliot Sanchez for preparing the figures and formatting the publication.

Collecting samples

Collections of disease samples are extremely useful in studying disease symptoms and forming representative pathogen populations. The isolates can later be used for artificially inoculating host genotypes in selecting for resistance.

When collecting field samples, it is important to take into account such factors as crop growth stage at the time of collection, plant part to be collected, lesion development, and prevailing environmental conditions. Collection data such as location, date, crop, and variety, as well as symptom description, should be specified for each sample.

Preserving samples

Samples can be placed in paper or plastic envelopes, unless the weather is hot and humid, because these conditions favor saprophyte development. Samples should be dried as soon as possible. In general, plastic bags are used only in emergencies or when other types of containers are unavailable.

A press is recommended for drying the samples (see below for instructions on how to build one). Place plant tissue in the press in such a way that symptoms are readily visible. When samples consist of leaves whose adaxial and abaxial sides are different, two leaves are used, one face up and the other face down. If a press is not available, samples can be laid out in the same manner on newspaper or blotters and a weight placed on top.

The dried sample and its corresponding data are transferred to a diagnostic sheet. If the necessary equipment is available, samples are observed under the microscope or isolates made, to start the identification process. All observations made during this process (signs and symptoms, morphology) should also be added to the diagnostic sheet (Figure 1; Zillinsky, 1983). In this way, a reference sample of the most important diseases in a region can be made that includes data which later will facilitate pathogen identification and help to understand local phytosanitary problems.

How to build a press. A press consists of two base parts made of a durable, strong material such as wood (Figure 2a, b). Nail together four wood strips 1.5 inches wide to form a 12" x 18" (30.5 cm x 46 cm) rectangle, as shown in Figure 2b (measurements can be adjusted as needed). Place newspaper between the two bases to dry plant samples. To apply and maintain constant pressure on the samples, use two 1" (2.54 cm) wide leather strips for tightening the press (Figure 2b).

If samples are to be used for starting a collection of the pathogen population, dry them for 48 h, making sure they are properly identified. After drying, samples are transferred to paper envelopes, which in turn are placed inside plastic bags. Plastic bags should be sealed to keep out moisture and stored at 4°C.

Basic requirements of a plant pathology laboratory

Laboratory work is extremely important in plant pathology. Basic research is conducted in the lab, plant pathogens are isolated and identified, and inoculum is produced for doing artificial inoculations in both field and greenhouse.

Basic equipment

A lab should be equipped with sterilizers, autoclaves (gas or electric), ovens, isolation chambers, incubators, microscopes, stereoscopes, and water baths, among other things.

Autoclaves. Used for sterilizing with moist heat. Water vapor inside an autoclave can reach a temperature of 120°C and 18 lb/in³ (1.4 kg/cm²) pressure. The heat source may be electric or, in the case of a pressure cooker, a gas burner. A pressure cooker works like a big autoclave but has the advantage of being very low-cost. Both devices are used primarily for sterilizing artificial media but can also handle soil, sand, vermiculite, or any other substrate used for growing plants and microorganisms.

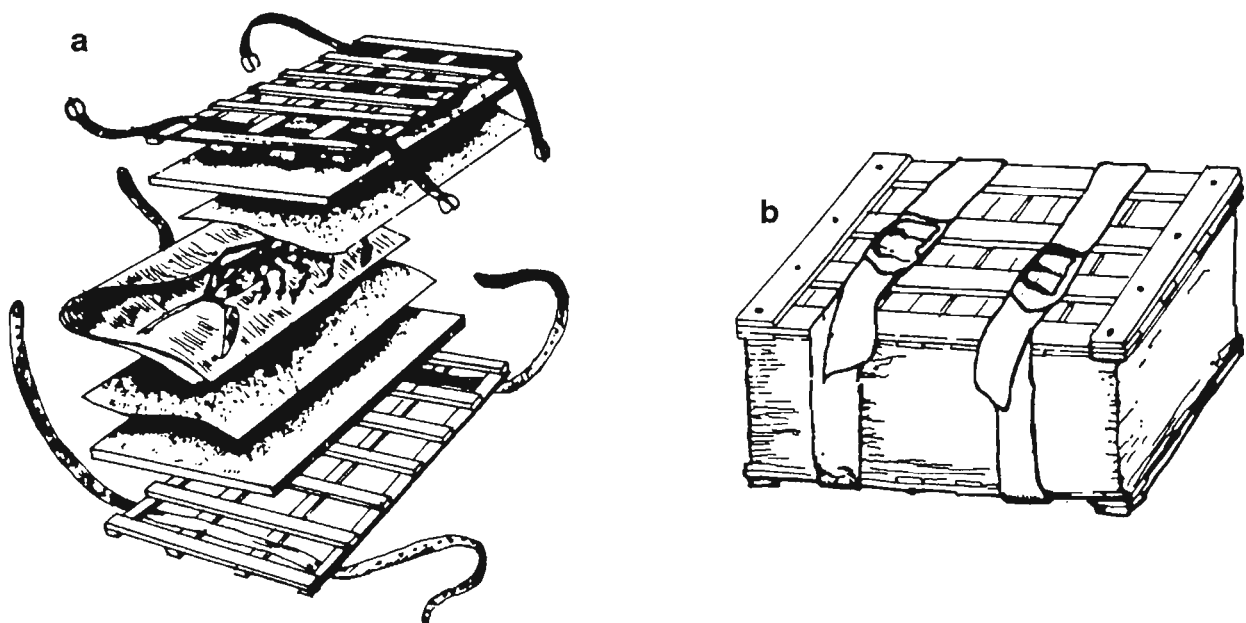

Figure 2a. Parts of a press. b. Finished press.

Ovens. An oven provides a wide temperature range by means of dry heat. It is used for drying plant or soil samples at constant temperatures and sterilizing glassware at high temperatures.

Isolation chambers. Laminar flow chambers (LFCs) have an air flow mechanism that filters outgoing air. This avoids contamination by microorganisms and provides sterile conditions. Microvoids work much the same way as LFCs but are smaller and cheaper. If LFCs and microvoids are not available, a small room with no air currents and a gas or alcohol burner (to avoid contamination) may serve as an isolation chamber.

Incubators. An incubator can be calibrated to a wide range of light/temperature combinations. Incubators are extremely useful for artificially growing many plant pathogens requiring specific light/temperature conditions. Partial incubators can be built by hand out of wood; near-ultraviolet (NUV) light is supplied by fluorescent tubes, and a light control is used to regulate light/darkness cycles (Figure 3a, b). Since temperature cannot be controlled in this type of incubator, it should be located in a place where temperature is 15-22°C, the range at which many plant pathogens develop.

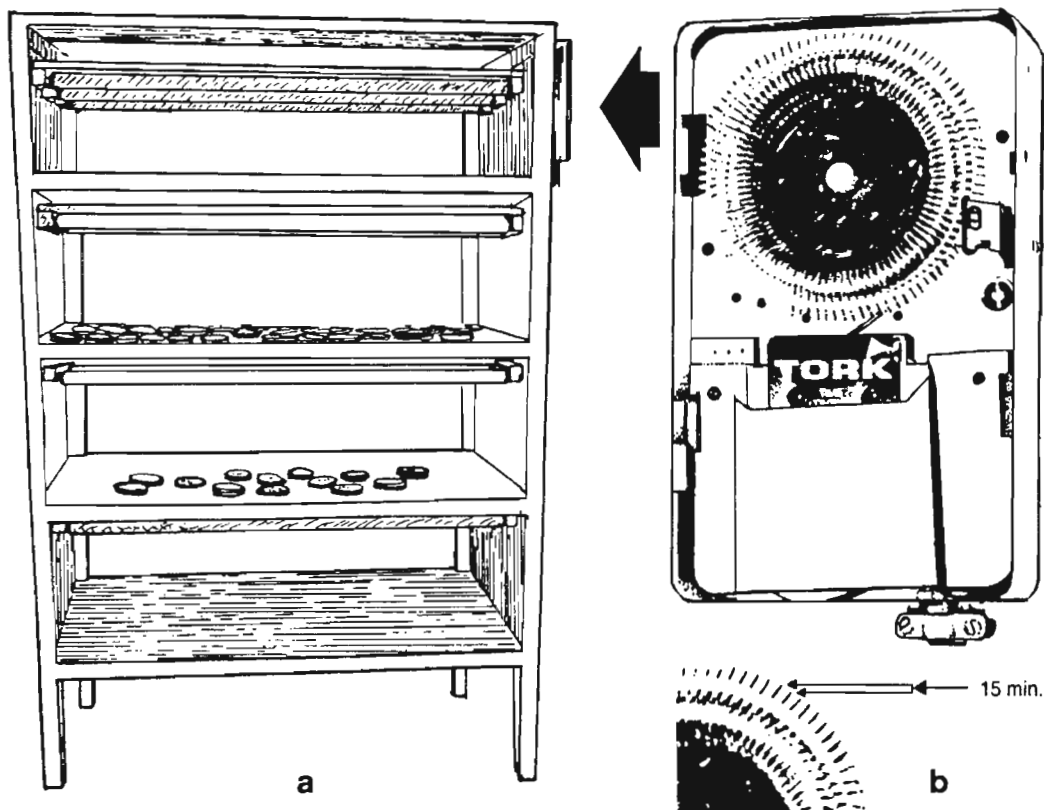

Figure 3a. Handmade growth chamber. b. Clock used as light control.

Refrigerators. Essential mainly for storing plant material, cultures, artificial media, reagents, etc.

Water bath. This device consists of a container that maintains water at a constant temperature. Water baths have many uses. For example, Erhlenmeyer flasks containing freshly sterilized culture medium can be placed in a water bath at 46°C to cool it before pouring into Petri dishes. Water baths are essential for measuring growth of some organisms in liquid media at specific temperatures, and have other uses in bacteriology and virology.

Microscopes and stereoscopes. Essential for the identification, classification, and quantification of plant pathogens, as well as for observing symptoms and lesions and evaluating experiments.

Maintaining a microbe-free environment

A microbe-free environment is essential in a plant pathology laboratory, since it is required for most of the work that goes on there. For this reason, it is important to have LFCs, microvoids, or isolation chambers in which to work with specific pathogens without the risk of contamination. Contamination may come from various sources such as utensils and human hands. Work utensils (needles, forceps, etc.) should be sterilized after every use by cleaning them with alcohol and flaming. Hands should be washed and cleaned with alcohol before working under sterile conditions.

Care must be taken because some fungi present as saprophytes in many tissue samples or in the lab environment may grow and reproduce rapidly. Plant tissue samples brought into the lab should be kept to a minimum and above all should not be handled as inoculum within the lab. It is very difficult to control contamination in the lab once it has occurred.

Mite contamination is also common, especially in Petri dishes that have been deformed as a result of dry heat sterilization. Mites can invade poorly sealed dishes or test tubes and contaminate the contents. This type of contamination is hard to control. It is therefore essential that plant materials collected in the field be properly disinfected; in addition, care must be taken when handling cultures from other labs, tubes and plates should be well sealed, and incubators should be fumigated. If mite contamination does occur, incubators and ovens must be emptied completely and turned on for a couple of hours at a temperature above 50°C; repeat the procedure two days later.

To avoid contamination problems, all plant materials entering the lab must be controlled. In addition, work tables should be routinely cleaned with alcohol or sodium hypochlorite.

Sterilization

Techniques for isolating, identifying, and multiplying inoculum, and biological and physiological studies of pathogens require pure cultures. A microbe-free environment is therefore essential. Sterilization of utensils, equipment, and work areas means that all living cells (microorganisms) must be eliminated or inactivated. This is done by physical or chemical means that irreversibly destroy the protoplasmic structure of cells. Selection of the sterilization method depends upon efficiency and safety requirements, taking into account toxicity, availability, cost, and the effects of the sterilizing agent on the physical and chemical properties of the object to be sterilized.

The most common physical methods are heat, ionic radiation, and ultrafiltration (for some liquids). Heat sterilization is used when materials to be sterilized are not damaged by high temperatures under dry or moist conditions.

Dry heat. Used to sterilize utensils made of glass, metal, and certain kinds of plastic. This type of sterilization requires higher temperatures and longer exposure than moist heat processes, and also hot air ovens that produce uniform heat. The time of exposure is inversely proportional to the temperature; for example, 1 hr at 180°C, 2 hr at 170°C, 4 hr at 150°C, and 12-16 hr at 120°C. Start counting sterilization time when maximum temperature is reached. Glassware should be completely dry, otherwise it may break. Graduated materials should not be sterilized by this method because their dimensions may change. To avoid breakage, sterilized materials should be left in the oven until they reach room temperature.

Moist heat. The most convenient method for sterilizing most materials, moist heat is quick and has greater penetrating power at lower temperatures in a shorter period of time. It requires using water vapor pressure inside an autoclave. For most purposes, exposure is 20 minutes at 121°C or 30 minutes at 115°C. It is important to expel all the air from the chamber before closing the valve; if not, temperature will not rise. Exposure is calculated starting from the time desired temperature and pressure are reached (15 lb/in³ or 1.4 kg/cm²). Moist heat can be used on liquids, plastics (although not on all of them), soil, sand, and vermiculite.

Ultraviolet light. Ultraviolet light is used for sterilization because it kills most microorganisms. While it is recommended for plastic materials, it cannot penetrate glass. Ultraviolet systems must be installed in a closed chamber to avoid exposure, since it is harmful to the eyes.

Ultrafiltration. Used when proteins and sugars (which break down easily if exposed to high temperatures) must be kept intact. Filters act as barriers for microorganisms. Their size and consistency vary depending on the microorganisms to be filtered.

Disinfection

When contaminants must be removed from objects that cannot be subjected to sterilization, the best option is disinfection with chemicals such as mercuric chloride, sodium hypochlorite, alcohol, and ethylene bromide. The most commonly used substances are sodium hypochlorite and alcohol at concentrations that vary depending upon the object to be sterilized. When isolating pathogens, chemicals are useful for removing contaminants from samples, for example, 1% sodium hypochlorite for plant material (leaves, roots) and 3-5% for seeds. Alcohol (70%) is widely used for disinfecting surfaces or even plant material.

Culture media

In identifying plant diseases, potential causal agents need to be isolated. In order to do this, microorganisms (mainly fungi and bacteria) are isolated in artificial media, where they are purified and stimulated to sporulate and produce inoculum. The resulting inoculum is used for artificial inoculations to produce disease symptoms, a process which is necessary for pathogen identification (Koch's postulates). The Appendix summarizes information on culture media used for growing and preserving cereal pathogens.

Types of media

Culture media are solutions for growing one or more microorganisms. They may be solid or liquid; the only difference is that solid ones contain agar, are prepared in flasks, petri dishes, or test tubes and are used for isolating and maintaining fungi and bacteria. Liquid media are used mainly for increasing fungal and bacterial populations, and determining their physiologic properties either in stationary fashion or in a shaker. This allows greater aeration, which promotes uniform growth and helps maintain pathogenicity. Based on their composition, different media may be classified as:

Non-nutrient media. Used to obtain monosporic cultures, isolate pathogens from plant tissue, and force sporulation of some fungi. Water-agar is the most common example of this type of medium.

Nutrient solutions. May be natural, semi-synthetic, or synthetic. Natural solutions only contain plant tissue (leaf, root, pod, and grain) in small pieces or crushed, and have been sterilized. Semi-synthetic solutions contain both natural (animal or plant extracts and processed plant products such as maize flour and oat bran) and synthetic

compounds. Synthetic solutions are composed entirely of chemicals and can be reproduced for specific experiments.

Some semi-synthetic and synthetic media are available in dehydrated form to which water is added. *Only distilled water should be used to mix culture media.*

Deciding which culture media to use

The type of culture medium that should be used will depend on the objectives of your study, e.g., isolation, physiological or biological studies (which require the production of sexual and asexual structures), or inoculum production. Choosing the appropriate medium is very important, since the pathogen's infectivity and capacity to produce propagules will depend greatly on it. Another important factor in culture media is the pH level which, in the case of fungi, is generally 5.8-6.5, but may vary depending on the pathogen.

Some physical factors (aeration, light, humidity, and temperature) affect pathogen growth and sporulation. Minimum and maximum points as well as optimum levels for growth and sporulation will vary according to the pathogen under study. Sporulation usually requires conditions unfavorable to vegetative growth.

Lab practice

Media preparation

When preparing culture media, paying attention to details will make your work more efficient. For example, fill containers only halfway to keep the contents from soiling the lids during sterilization; flasks should be covered with cotton, aluminum foil or both. After sterilization is completed, do not remove covers until sterile conditions are met or a burner is available. To cool the medium, place in a water bath at 46°C for 30 minutes, but if a water bath is not available, you should wait until the medium cools somewhat before pouring into the Petri dishes. (A practical way of determining when to pour is to touch the container with the back of the hand; if it feels warm, it's ready to pour.) This keeps condensation, which promotes contamination, from forming inside the plates. Pouring media into Petri dishes or test tubes should be done in a sterile chamber or a draft-free room using a burner. It's best to heat the mouth of the flask, avoid opening the dishes too widely, and try to keep a minimum distance between flask and Petri dish to avoid contamination (Figure 4).

The medium should be poured 24-48 h before use, to allow any condensation to dry. Another way to avoid condensation is to stack the Petri dishes one on top of another as they are filled with medium (Figure 4).

When tubes, flasks or other types of containers are to be used, heat can be used to homogenize the medium. Pour the medium into the containers (Figure 5a), cover, sterilize, and let cool. Test tubes are usually cooled in a slanted position to provide greater area for growth (Figure 5b).

Culture media most commonly used for isolating and growing fungi. To identify and study pathogens, it is necessary to isolate and grow them. Thus practicing the preparation of some of the more commonly used media is recommended.

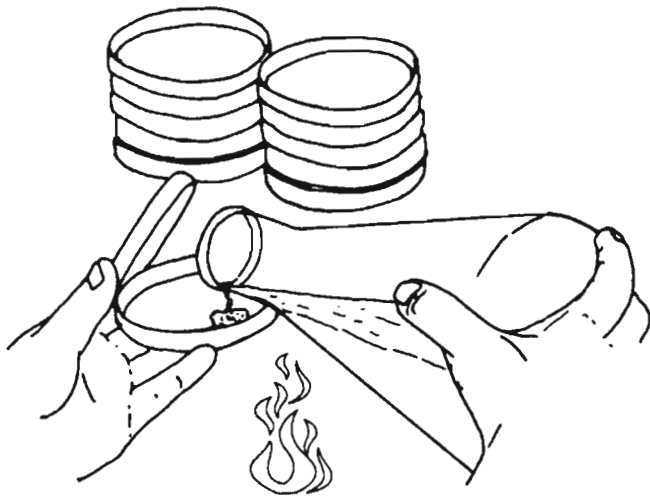

Figure 4. How to pour culture media and avoid condensation.

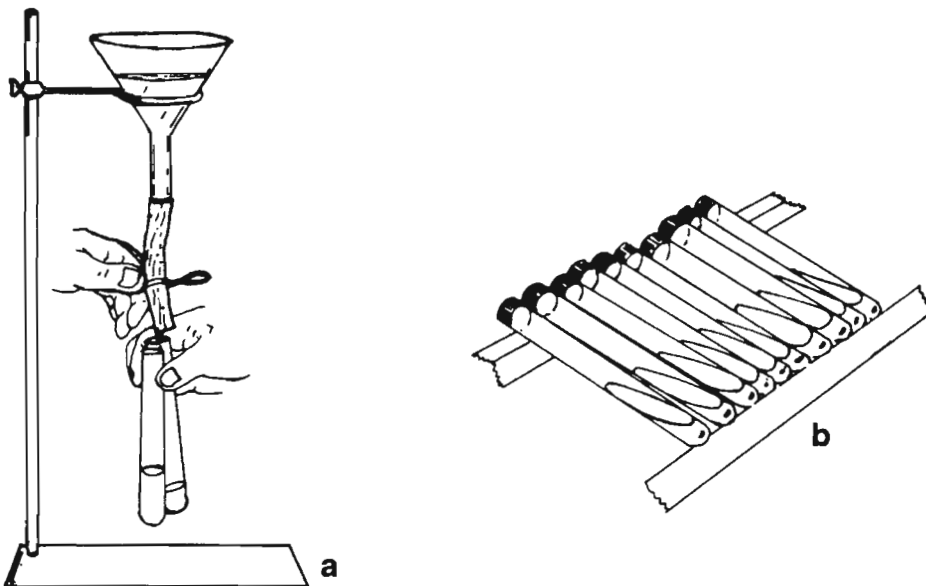

Figure 5a. Pouring medium into test tubes. **b.** Cooling medium-filled test tubes at a slant to provide larger growth surface.

1. **Water-agar:** Often used to isolate and germinate spores, obtain monosporic cultures, and verify inoculum viability.

Components:

Agar	15-20 g
Distilled water	1000 ml

Preparation: Using a flask (half full), dissolve agar in water and sterilize.

2. **Potato-dextrose-agar (PDA):** Most widely used for isolating, multiplying, and storing fungi because it is suitable for a large number of species.

Components:

Sliced potatoes	250 g
Dextrose	10 g
Agar	20 g
Distilled water	1000 ml

Preparation: Boil the potatoes in 500-700 ml of distilled water for 15-20 minutes. Filter through cheesecloth; pour into a flask and add dextrose, agar, and enough water to reach 1000 ml. Seal flask with cotton or aluminum foil and sterilize. Let cool and pour into Petri dishes (halfway). Stack dishes one on top of another to avoid condensation.

In many countries, dehydrated PDA is available on the market; add distilled water according to the manufacturer's instructions and sterilize as follows. Place 9.75 g dehydrated PDA in a 500-ml flask and add 250 ml distilled water. Heat suspension to homogenize; pour 4-5 ml of medium into each test tube using a syringe. Seal tubes and sterilize; let cool at a slant until solid (Figure 5b). If a syringe is not available, use a funnel on a metal stand. Adjust a piece of flexible tubing to the end of the funnel, regulating outflow by means of a pinch clamp. Measure out the desired amount of medium into one of the test tubes, to use as a guide during pouring (Figure 5a).

3. **V-8 agar:** Useful for inducing sporulation in many fungi. V-8 juice is made by the Campbell Soup Co. and Herdez, a Mexican firm, among others; it contains tomato, celery, beet, parsley, lettuce, spinach, and watercress extracts. Since there are differences among brands, comparative testing on each species is recommended. If canned V-8 juice is not available, it can be replaced with a medium containing leaf extract (such as the following), especially for testing *Helminthosporium tritici-repentis* and *H. teres*.

Components:

V-8 juice	200 ml
Calcium carbonate	3 g
Agar	15-20 g
Distilled water	800 ml

Preparation: Place agar and calcium carbonate in a flask; add the juice and mix with water to complete 1000 ml. Seal the flask and sterilize. Stir the medium before pouring to keep the juice from precipitating. This medium may be prepared at different concentrations by adjusting the amount of juice used.

4. **Leaf extract medium:** Used primarily for stimulating growth and formation of asexual structures in some fungi. Leaves of different crops may be used, depending on the pathogen.

Components:

Agar	15-20 g
Distilled water	1000 ml
Fresh leaves (wheat, oats, barley, etc.)	100 g
Sucrose	10 g

Preparation: Boil leaves for 20-30 min and filter the water. Add filtrate to agar and mix with water to 1000 ml. Sterilize and pour into Petri dishes or test tubes.

5. **4-4-4 agar-malt-yeast medium:** Frequently used for isolating and multiplying *Septoria tritici*.

Components:

Malt extract	4 g
Yeast extract	4 g
Sucrose	4 g
Agar	18 g
Streptomycin	0.1 g
Distilled water	1000 ml

Preparation: Place all ingredients except the antibiotic in distilled water. Mix well and sterilize for 20 min. Add the antibiotic while the medium is still warm, then pour into Petri dishes or test tubes.

6. **Medium for *Septoria nodorum*:** Recommended for the development and growth of *S. nodorum* pycnidia.

Components:

Malt extract	3 g
Yeast extract	2 g
MgSO ₄ ·7H ₂ O	0.5 g
Agar	20 g
Streptomycin	0.1 g
Distilled water	1000 ml

Preparation: Mix all the ingredients and sterilize for 20 min; add the antibiotic while the medium is still warm, then pour into Petri dishes or test tubes.

7. **Medium used to increase *Fusarium graminearum*:** If Chinese bean is available, this medium is inexpensive and very efficient for producing large amounts of inoculum.

Components:

Chinese beans	20 g
Distilled water	1000 ml

Preparation: Boil the beans in water for 20 min; filter the solution and sterilize the filtrate for 20 min in 500 ml flasks (just half full).

Inoculum increase: Inoculate the liquid medium and shake for five days.

8. **Lima bean agar:** This medium is utilized for *Rynchosporium secalis* isolation and inoculum increase, as well as for fungi that attack the roots and crown. It can be prepared from lima beans or commercial preparations can be purchased.

Components:

Lima beans	8 g
Agar	15-18 g
Distilled water	1000 ml

Preparation: Boil the lima beans in water for 20 min; filter the infusion, add the agar and sterilize for 20 min.

9. **Saccharose-yeast liquid medium:** Used only for increasing *Septoria tritici*, and only if a shaker is available and existing conditions favor daily inoculum applications, since viability is lost after five days.

Components:

Sacarose	10 g
Yeast extract	10 g
Distilled water	1000 g

Preparation: Mix the components and sterilize for 20 min in 250-ml flasks. Let the medium cool, then inoculate and shake continuously during the entire incubation period. Use the inoculum after five days.

10. Leaf segment medium: Appropriate for stimulating the formation of sexual structures in some fungi.

Components:

Agar	15-20 g
Distilled water	1000 ml
Small pieces of fresh leaves (try different species)	

Preparation: Dissolve the agar in water. Place the leaf pieces in Petri dishes and sterilize. Pour the sterilized water-agar into the plates. When the agar has nearly solidified, place 5-10 leaf pieces on each plate so they will stay in the top part of the agar. The pieces are inoculated with the fungus under study and periodically observed.

Media for fungal conservation. In preserving and managing fungal cultures, the number and frequency of isolate transfers should be reduced to once every six months. To avoid changes in pathogenicity, isolates should be maintained in as natural a substrate as possible (for example, wheat leaves for *Pythium*; wheat seed for *Fusarium* and other fungi). Preservation procedures vary depending on the pathogen under study.

1. Grains: A great variety of grains are used to preserve certain fungi. In this way, the fungi maintain their stability and do not lose their virulence or their sporulating capacity, as they would in some synthetic media. The type of grain used depends on the fungus you're working with.

The grain is soaked in distilled water for 24 hours; drain the excess water, and place the grain in test tubes, flasks or bottles. Close the lids without tightening, and sterilize in the autoclave for 2 h. Incubate for 48-72 h at room temperature (22°C) to make sure there are no contaminating fungi or bacteria. After incubation, inoculate the grain with a pure culture of the pathogen, and incubate for 7-10 days or more if necessary to obtain good sporulation. During incubation, move the tubes or flasks

every two days, striking them against your hand to keep a compact mass from forming and to facilitate fungal growth.

For isolate conservation, place the tubes or flasks in plastic bags and store in a refrigerator. For inoculum multiplication, extract and suspend culture in sterile distilled water and store at 4-5 °C, once it reaches the appropriate growth stage.

Wheat, barley, triticale and sorghum grain can be used as a substrate, depending on the pathogen's affinity. Media based on grain are commonly used for species of *Fusarium* and *Helminthosporium*. *Gaeumannomyces graminis* can be maintained and multiplied in sterilized oat seed following the procedure described above.

2. Sterile soil: Sterilize moist soil for 2 h in test tubes or flasks; repeat after an interval of at least 24 h. This allows any resistance structures that were not eliminated during the first sterilization phase to subsequently germinate (also recommended for grains). After sterilization, test tubes or flasks are ready to be inoculated with pure cultures.

3. Sterile water with leaf pieces: Very useful for preserving cultures of *Pythium* spp. This pathogen is kept in a wheat leaf and water medium. Wheat seedling leaves (5-6 leaves, 2 cm long) are air-dried and suspended in 9 ml distilled water in test tubes. Cover the tubes with cotton plugs and sterilize in an autoclave. Transfer the cultures aseptically by removing a piece of agar and allow them to grow for several days at room temperature; seal tubes with paraffin and keep at 4-5°C. Isolates thus prepared can be maintained for a year or more without doing additional transfers.

To re-initiate growth, take a small leaf segment from the cultures and place in corn meal agar (CMA). Not all species can survive long periods stored in this way; therefore, if you are working with *Pythium*, isolates should be transferred every six months until the viability of the species under study is determined.

4. Leaf extract medium: Used specifically for preserving *Septoria tritici* isolates for long periods without changes in virulence.

Components:	
Wheat leaves	30 g
Bactoagar	20 g
Streptomycin	0.1 g
Distilled water	1000 ml

Preparation: Leaves are crushed in a mortar or blender with water, then filtered through cheesecloth to separate larger fragments; add agar and sterilize for 20 minutes. When the medium is warm, add the streptomycin and mix gently using a rotating motion to homogenize, taking care not to splash the medium on flask walls and lids. Pour into Petri dishes, meting out just enough medium to cover the bottom of the plates. For long-term storage, inoculate the medium by placing *Septoria* conidia in the center of the plate. Stack several plates together and cover with aluminum foil; keep them at 20-25°C until the water from the medium evaporates (approximately three months). Mature pycnidia should have formed at the end of that time. Isolates thus prepared can be maintained for long periods (up to three years) at 4-6°C.

To re-activate the culture, pycnidia are extracted and placed in a medium appropriate for *Septoria* growth. However, it should be noted that not all isolates are able to form pycnidia in this medium.

5. Preservation on dried, infected leaves: *Helminthosporium tritici-repentis*, *H. teres* and *Rynchosporium secalis* are difficult to maintain in culture media because their pathogenicity and sporulation capacity can be drastically reduced or irreversibly destroyed. To avoid this problem, inoculate the isolates onto susceptible cultivars under controlled conditions. Leaves with developing lesions are dried at room temperature for 48 h and then stored at 4°C. *Helminthosporium tritici-repentis* can remain viable for six months under these conditions. Isolates of *R. secalis* are placed in a tight plastic container and stored in a freezer at -15°C. This protocol should be tested on other species that also cause foliar lesions.

Bibliography

- Barnes, E.H. 1968. Atlas and Manual of Plant Pathology. New York: Plenum Press.
- French, E.R., and Teddy, T.H. 1982. Métodos de investigación fitopatológica. 1a edición. 1a. reimpresión. San José, Costa Rica: IICA.
- Tuite, J. 1969. Plant Pathological Methods. Fungi and Bacteria. Department of botany and plant pathology, Purdue University, Lafayette, Indiana.
- The Commonwealth Mycological Institute. 1968. Plant Pathologist's Pocketbook. Commonwealth Agricultural Bureau.
- Zelibovitch, N., and Z. Eyal. 1989. Maintenance of virulence of *Septoria tritici* cultures. Mycological Research 92(3):361-364.
- Zillinsky, F.J. 1984. Common Diseases of Small Grain Cereals: A Guide to Identification. Mexico, D.F.: CIMMYT. 141 pp.

How to prepare moist chambers

Moist chambers are a quick, direct way of stimulating sporulation and helping to identify the causal agents of some diseases. They are especially useful for identifying microorganisms that show rapid growth on the host and compete well with saprophytes in a moist chamber.

Preparation: Cut leaves or stems into small pieces and tape them onto a sterile slide. Sterilize pieces with 5% sodium hypochlorite for 30-60 seconds; rinse samples in sterile water to remove hypochlorite and dry on paper towels. It's a good idea to leave a few pieces untreated because some pathogens are very sensitive to sterilization. Do not select heavily damaged tissue to avoid saprophytic organisms. Place filter paper disk on the bottom of the Petri plate and moisten it thoroughly with sterile water (Figure 6a). Place the slide on the paper disk (Figure 6b). Close the plate and seal it with parafilm to hold in moisture (Figure 6c). Incubate plate at 18-22°C under alternating cycles of light and darkness (10 h light/14 h darkness) (many fungi will not develop to the reproductive stage without this alternating light/darkness regimen).

Open the plate after 24, 48 and 72 h of incubation. Place the slide under the dissecting microscope, and observe the structures that have developed on the lesion. If necessary, take a tiny portion of the fungal growth with a dissecting needle and put it in a drop of water on a slide. Cover the slide, being careful not to form air bubbles (use a dissecting needle as an aid). Look for mycelium, conidia, conidiophores, and other fungal structures under the compound microscope. If no structure is visible, close and seal the plate again to make sure it doesn't lose moisture and continue observation. Draw any observed structure.

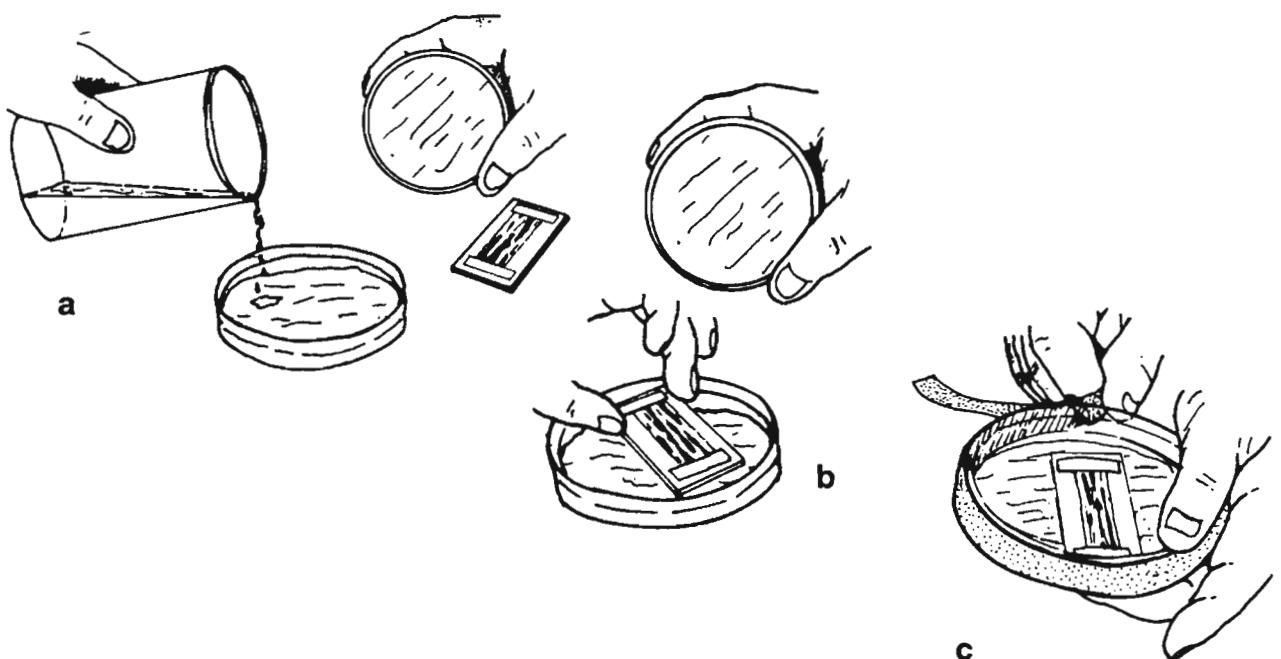

Figure 6 a, b, c. How to prepare a moist chamber.

Preparing specimens for observation under the microscope

In diagnosing and studying diseases, it is usually necessary to isolate and artificially culture the pathogen in order to identify it properly. It is very useful to observe microscopic preparations taken directly from diseased tissue or from an isolate.

Mounting preparations. Place the sample on a clean slide in a drop of mounting solution, preferably sterile water or a dye for staining fungal structures to be observed in greater contrast. Lactophenol, safranin and cotton blue are among the most commonly used dyes.

Preparations from diseased samples can be obtained in various ways depending on the material: if the plant tissue has a cottony appearance or shows signs of pathogen structures, take a sample by scraping the diseased tissue gently with a dissecting needle or the tip of a razor blade (Figure 7 a). Carefully place the sample on the slide in a drop of water or dye (Figure 7 b). Then place a coverslip gently with the help of a needle, making sure that it covers the specimen completely without air bubbles (Figure 7c).

Use scotch tape for fast, non-permanent preparations of fungal growth in culture media. This method is recommended for observing structures in their normal position and growth stage (chains of spores, conidia or conidiophores). With the previously described methods, the structures generally separate when they are touched with a needle.

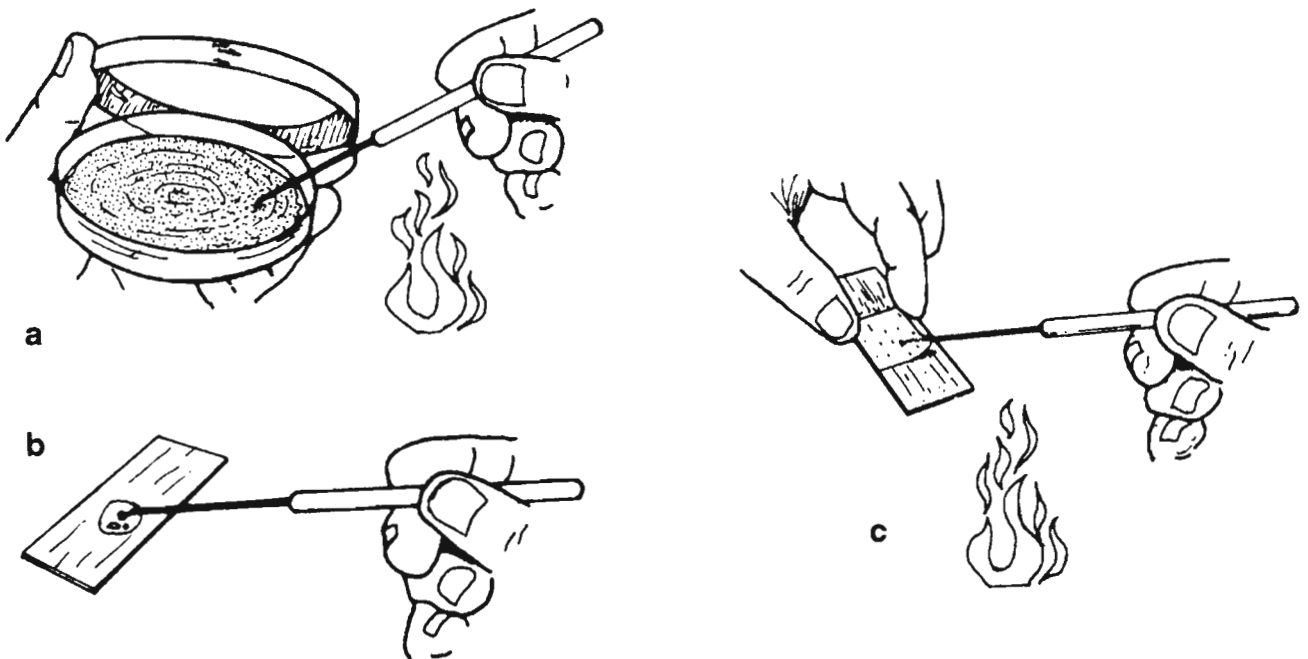

Figure 7 a, b, c. How to make a preparation for observation under the microscope.

Take a piece of scotch tape and lightly touch the sample or the culture on the Petri dish or diseased tissue with the sticky side (Figure 8 a); then, place it on a drop of sterile water on a slide (Figures 8 b, c).

When more detailed observations are needed (for example, of pathogen structures within plant tissue), thin sectioning of the sample can be accomplished with a razor blade or a scalpel. Gently hold leaves, stems, tubers, roots, etc., in position between fingers for sectioning (Figure 9 a). Such sectioning of tissue samples will produce clean cuts similar to those obtained with a microtome, an instrument designed for this purpose that is generally not available because of its high cost. Sections should be placed in a drop of mounting medium. Use a flat piece of wood or a longitudinal piece of carrot for support when cutting soft, flexible plant tissues. With the tip of the sample protruding, cut sections as thin as possible (Figure 9 b). Use this technique to produce clear, complete sections of fungal structures such as pycnidia and perithecia, as well as better and clearer images of naturally dark tissues.

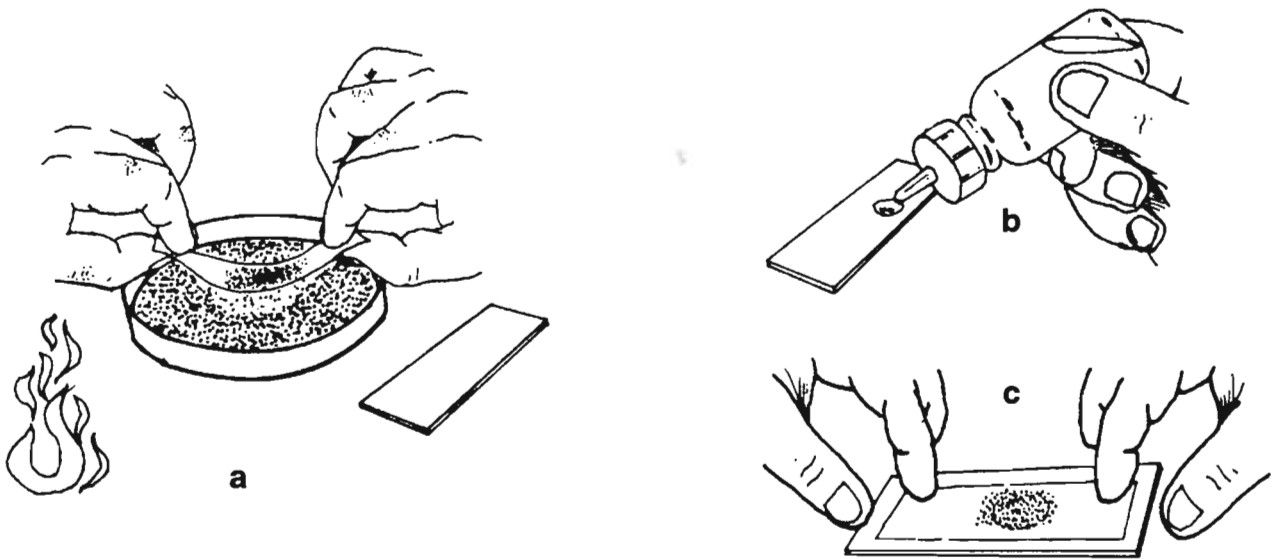

Figure 8 a, b, c. Making a preparation using scotch tape.

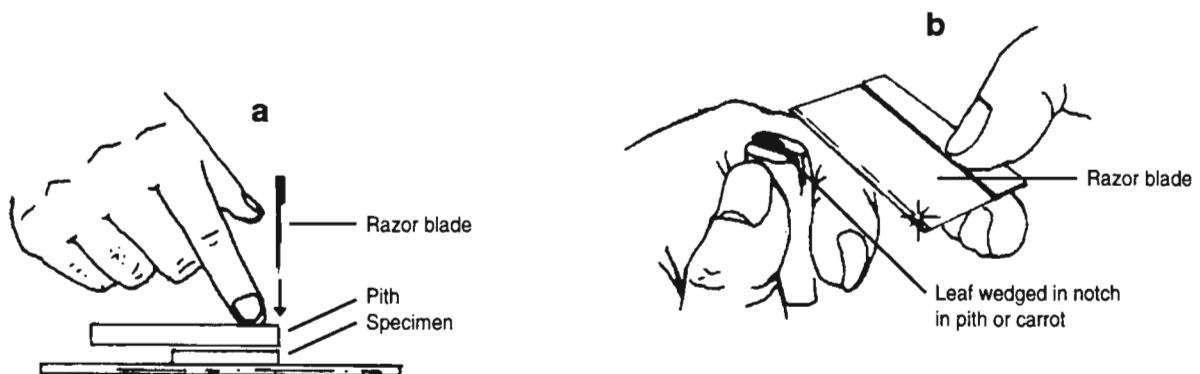

Figure 9 a and b. Making fine sections of fungal structures.

After placing the specimen in a drop of mounting medium, use a dissection needle to put it in the desired position. Then use the needle to gently lower the coverslip onto the slide, starting on one side, making sure it covers the specimen completely without air bubbles, which can distort the image under the microscope. If necessary, softly press the coverslip to force out excess solution and blot with filter paper or a paper towel.

To make semi-permanent preparations, flame the slide containing the sample for several seconds until the drop of mounting medium boils (to eliminate bubbles); eliminate excess medium outside the coverslip with filter paper.

Apply clear fingernail polish on the four sides of the coverslip to seal the sample.

Determining inoculum concentration

When evaluating germplasm for disease resistance or when doing specific studies on a pathogen (epidemiology), it is often necessary to rely on artificial inoculation either in the greenhouse or in the field. The appropriate inoculum concentration (number of spores per milliliter) is determined depending on the host and pathogen under study. The resulting infection should allow us to distinguish between resistant and susceptible materials.

Concentration is determined with the help of a haemocytometer, with which spore counts are made in fields of known dimensions. This provides the number of spores per ml of the initial suspension. Once the concentration of the stock suspension has been determined, one can dilute the suspension as needed.

Procedure: Scrape plates with pure cultures of the fungus and suspend in a known volume of distilled water. Stir the suspension to make it homogeneous, and filter it through gauze or a coarse sieve to get rid of agar or other materials that may block the nozzles during inoculation. Bring the filtrate to a known volume with distilled water.

Using a Pasteur pipette, place a drop in the middle of the haemocytometer chamber or place a drop on each side, depending on the kind of haemocytometer you are using. Then place the coverslip over the chamber making sure there are no air bubbles and that the drop does not spill over the edges. Since the excess carries spores, this could produce an erroneous count.

The haemocytometer has two counting fields, each of which is divided into nine large squares; each square is subdivided into smaller squares (Figure 10). Since the sizes of both squares are known, the number of spores/ml can be determined using specific formulas.

The counting field to be used is determined by spore size. If spores are large, it is easier to use the four large corner squares (A, B, C, D) and the middle one (E) (Figure 10). Spore counts are done at least six times, and then the average of the six counts is calculated.

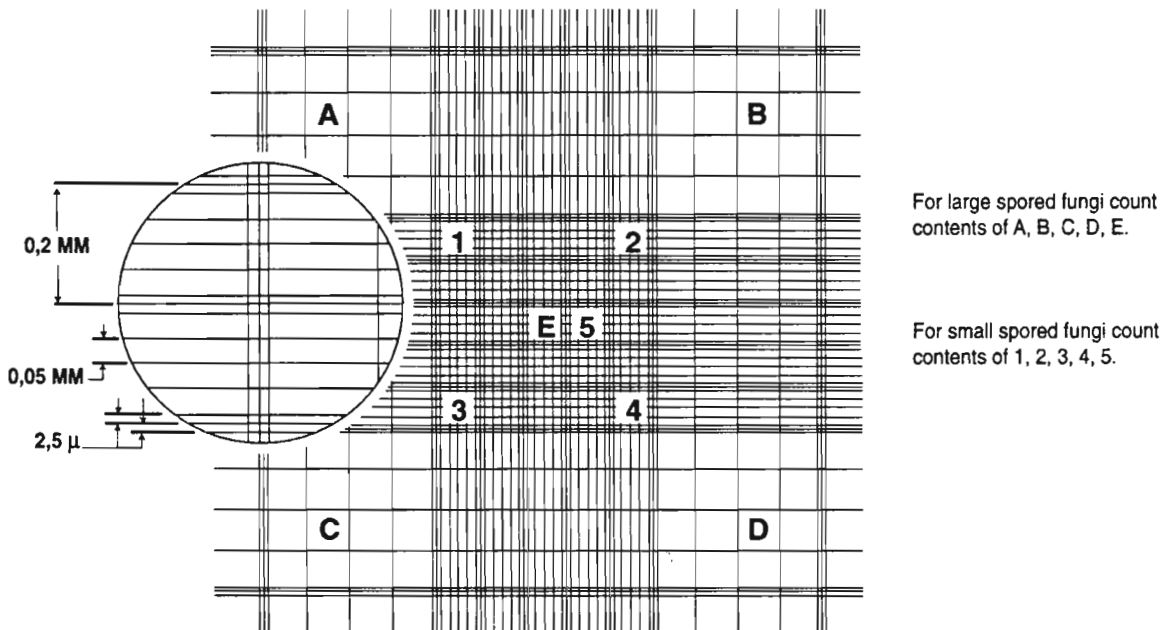

Figure 10. Haemocytometer diagram showing the counting fields (A, B, C, D, E).

Example:

Counting fields

Count number	A	B	C	D	E	Total
1	10*	15	12	13	11	61
2	18	15	10	20	13	76
3	25	15	18	16	14	88
4	12	14	15	18	13	72
5	15	13	17	14	11	70
6	15	13	12	18	20	78

*No. of conidia or propagules

445

Mean = 74

With the resulting data, calculate the mean, which is multiplied by a constant factor depending on the haemocytometer used. This will give the conidia concentration per ml.

Then:

$$74 \times \text{factor} = \text{Concentration in conidia/ml}$$

This is the concentration of the initial suspension. To calculate a specific dilution, use the following formula:

$$C_1 V_1 = C_2 V_2$$

Where:

C_1 = Initial concentration (from spore counts)

V_1 = Initial volume (arbitrarily established when inoculum is prepared)

C_2 = Final desired concentration (depending on study)

V_2 = Final volume (unknown)

Thus:

$$V_2 = \frac{C_1 \times V_1}{C_2}$$

If the initial volume was 100 ml and a concentration of 30,000 conidia/ml is needed, then

$$V_2 = \frac{\text{estimated concentration} \times 100 \text{ ml}}{30,000} = \text{final volume (ml)}$$

With the resulting data:

- a) Estimate initial inoculum concentration.
- b) Estimate the amount of liquid that should be added to the spore suspension to obtain a concentration of 30,000 spores per ml.

Greenhouse inoculation

Artificial inoculation in the greenhouse has different purposes: to demonstrate Koch's postulates, produce inoculum, do symptom characterization, select for genetic resistance and conduct epidemiological studies. Inoculating under these conditions has the following advantages: better control of the pathogen, better symptom evaluation,

ensures there is no interference from other organisms (as happens in the field), and the inoculated material can be evaluated quickly. Generally, artificial inoculation in the greenhouse is carried out on seedlings. However, other phenologic stages of the plant can be used (depending on the pathogen under study).

The following inoculation exercise is very useful for selecting genetic material under greenhouse conditions and can help to speed up the selection process in a breeding program. Susceptible and resistant plants are used; they are inoculated with several *Helminthosporium* species. In the case of *Helminthosporium sativum*, *H. teres* f. sp. *teres*, *H. teres* f. sp. *maculata* and *H. tritici-repentis*, 10-12-day old seedlings are needed. Differences among plants and resistance reactions can be evaluated 5-7 days after inoculation.

Seedlings to be inoculated can be prepared in several ways. The two methods described in this exercise are similar, except at the beginning.

For the first method, use glassine bags with absorbent paper towels inside (Figure 11 a); staple them together in the upper part, leaving enough space to introduce seeds to be germinated. The bags containing seeds are placed in trays and supported by metal racks (Figure 11 b). Water added to the trays will be absorbed by the paper towel inside the glassine bags and reach the seed. This will allow seed germination and supply water needed later on. Always include susceptible and resistant controls.

In the second method, sow similar seed sets in paper cups filled with soil. As in the first method, include susceptible and resistant controls.

From here onwards, both methods are the same. When seedlings are 10-12 days old, scrape the pathogen cultured in Petri plates and dissolve in distilled water (if the culture is on grain, shake with water), filter through a cheesecloth to eliminate any pieces of agar and obtain as pure a conidial suspension as possible. Use the haemocytometer to adjust the concentration to 30,000 conidia/ml; if Tween 20 is available, add one drop to avoid aggregation of conidia and obtain a more homogeneous concentration. Inoculate seedlings uniformly using an atomizer (Figure 11 c). Separate seedlings inoculated with *H. sativum*, *H. teres* and *H. tritici-repentis*. Identify the non-inoculated controls and the susceptible and resistant ones.

Incubate the inoculated seedlings in a moist chamber for 2 h; then alternate 15 min moisture/45 min light during 48 h for *H. teres* and *H. tritici-repentis*, and 18-24 h for *H. sativum*. If a moist chamber is not available, similar results can be obtained by covering the inoculated seedlings with plastic bags, and making sure moisture is available continuously. Water the plants, spray the inside of the bags and seal them. The number of hours they are to remain in the chamber should be determined prior to the exercise

and adjusted to specific conditions. An electric humidifier is very useful, specially if connected to a timer that provides moisture at intervals predetermined according to the pathogen.

After 48 h (or 24, depending on the pathogen), remove seedlings from the chamber and transfer to the greenhouse for 8-10 days. Observe symptoms and try to differentiate lesions caused by *H. sativum*, *H. teres* f. sp. *maculata* and *H. teres* f. sp. *teres* from those caused by *H. tritici-repentis*. Evaluate differences in susceptibility of the different cultivars based on the scales given to you, using the susceptible and resistant controls as references (Figure 11 d).

Do the following project as an exercise. Indicate how you would select germplasm in the greenhouse or similar structure, with the facilities available in your country. For this project, choose a fungal disease that is economically important in the region where you work; adjust the procedure to the conditions required by the pathogen.

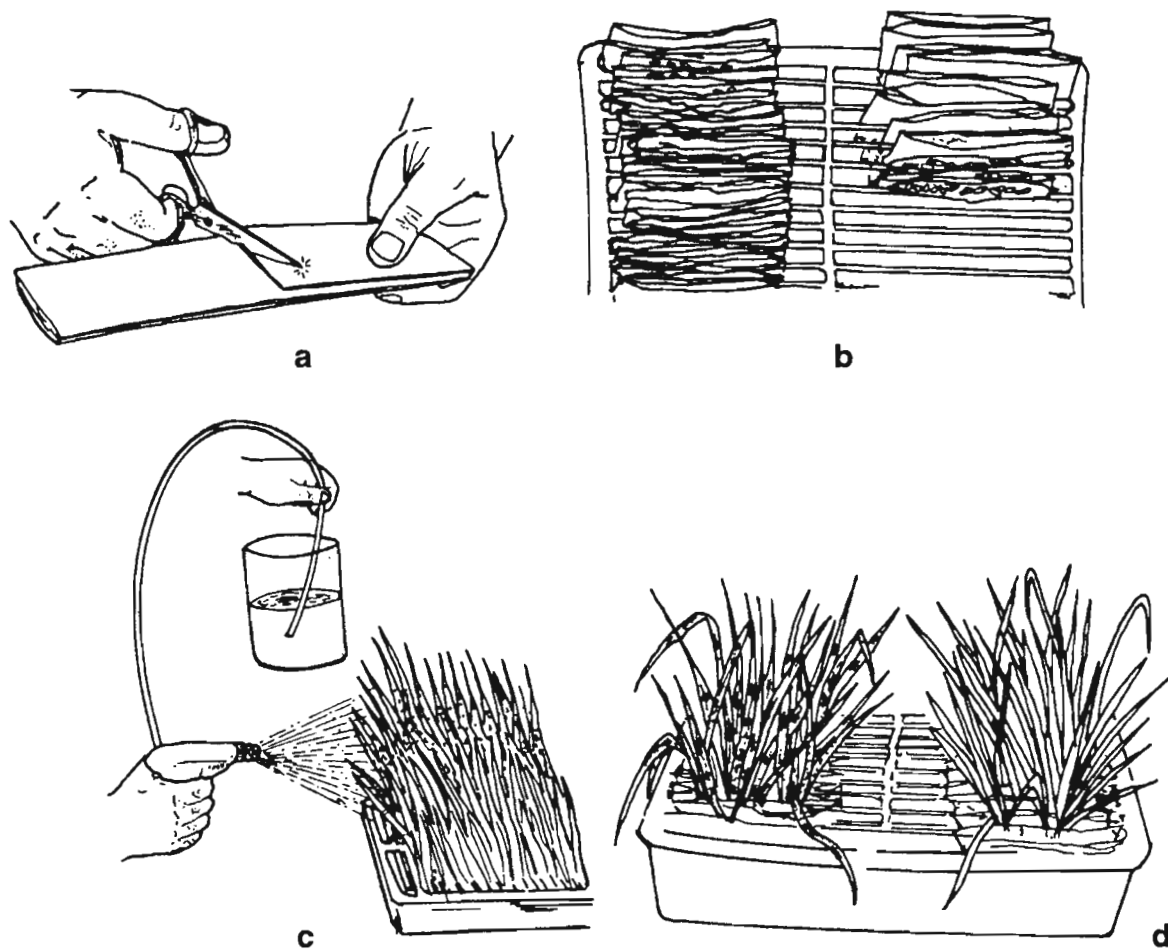

Figure 11 a, b, c, d. Trays adapted for growing and inoculating seedlings, and quickly selecting them for resistance to pathogens that cause leaf blights.

Introduction

Many species of Basidiomycetes are important parasites of cultivated plants, forest trees and ornamentals. Some species of this class (for example, mushrooms) are grown for human consumption; others are an important source of plant nutrients (mycorrhizal fungi), and many are saprophytes.

Spores (basidiospores) of these fungi are produced outside a specialized structure called a basidium, which may be septate (phragmobasidium) or non-septate (holobasidium). Basidiospores are the result of plasmogamy (fusion of two protoplasts), karyogamy (fusion of two nuclei) and meiosis.

The rusts

The rust fungi are a large, economically important group of plant pathogens. They attack most plant species, but on cereal crops they have been the focus of much attention for a long period of human history because of their high incidence and the severe damage they cause on those crops. The life cycle of cereal rusts typically includes sexual and asexual phases and as many as five different spore stages.

Wheat is attacked by stem rust caused by *Puccinia graminis* f. sp. *tritici*, stripe (yellow) rust (*Puccinia striiformis* f. sp. *tritici*), and leaf rust (*Puccinia recondita* f. sp. *tritici*). Stem rust is more prevalent in warm climates, whereas stripe rust is favored in cooler areas. An intermediate climate favors leaf rust, and today it is the most widespread and damaging of the three diseases.

Stem rust produces elongated, reddish brown pustules on the stems, sheaths and necks of the plants. Leaf rust lesions are slightly lighter (orange-brown), smaller and oval shaped, and most evident on leaf blades. Stripe rust is even lighter (yellow to orange-yellow) and occurs in a linear arrangement on various foliar parts and the glumes.

Development of effective control measures for wheat rusts started early in this century when it was discovered that resistance existed and was often inherited through a single gene. The capacity of a pathogen strain to overcome a specific gene for resistance is often conditioned by a single gene as well, and this host-parasite relation is called the 'gene-for-gene' concept.

As resistant cultivars were grown for years over large areas, pathogen strains appeared to which resistance was not effective. Strains that differ in their ability (virulence) to attack a cultivar or group of cultivars are called (physiologic) races. A race is defined as a different avirulence pattern observed among a group of pathogen cultures or isolates when tested on a set of selected host cultivars or lines.

For example, about 40 different major genes for leaf rust resistance have been discovered in wheat; however, isolates of the fungus possessing virulence for many of these genes have also been found. Since there are two descriptive classes (avirulence and virulence) of the pathogen possible for each of the 40 known host resistance genes, the possible number of races (i.e. different combinations of virulence/avirulence genes) is 2^{40} , or more than 34 billion. This gives us an idea of these pathogens' great variability. Single-gene resistance and the occurrence of races are also found with other fungi (for example, mildews and potato late blight).

Monitoring the leaf rust population

For the above reasons, it is important to monitor races of the pathogen, and to test new cultivars against them when breeding for resistance. This can give early warning that a race or virulence combination may be building up, and provide information useful in developing strategies for using resistance (for example, the release of cultivars).

Following are instructions on how to monitor a leaf rust population and determine its race composition. The objectives of this exercise are to: 1) become acquainted with leaf rust of wheat, and evaluate reactions of susceptibility and resistance in wheat; 2) illustrate the interaction of rust isolates with different wheat lines, and demonstrate the presence of races; and 3) provide techniques for the practical monitoring of virulence in a leaf rust population.

For this exercise, it is best to use seed of near-isogenic (or differential) lines of spring wheat cultivar Thatcher. Each line possesses a different single gene for resistance bred into spring wheat cultivar Thatcher through a process known as backcrossing. The genetic constitution of these 'isolines' is similar, except for their specific resistance gene. Isolines for all known genes or only for selected genes can be used for this exercise. Spores of at least two isolates of the leaf rust fungus are needed to show a differential response. Each isolate is the progeny of a single rust pustule.

1. Plant isolines as clumps (6-8 seeds each) in a tray starting from the front left corner (label the spot) and moving to the right. Keep in a greenhouse at 18-24°C until the first leaf is fully extended (about 1 week). Seedlings must be kept isolated from any rust-infected plants. Water and fertilize as needed.
2. Inoculate each set of isolines with a different isolate of the fungus as follows: suspend spores in mineral oil or water, and spray or rub onto the leaf surfaces. Be careful not to mix spores of different isolates; wash your hands and, if using a sprayer, rinse with 70% ethanol before inoculating the second set of isolines with another isolate of the fungus. Allow the seedlings to dry for about 30 min after inoculation.

3. Spores require free moisture on the leaf surface for germination and penetration. In nature this is provided by overnight dew. To provide the needed moisture, spray plants with fine water mist and incubate overnight in a closed moist chamber. The next day, open the chamber partially and allow plants to dry off slowly. After 1 h, transfer them to a greenhouse bench and maintain at 16-24°C. The period of host tissue colonization between penetration and sporulation is called the latent period. The length of the latent period can be determined by noting when the first rust pustules break the epidermis and release urediniospores. Pustule development takes about 10-14 days.
4. After two weeks, observe uredinia under a dissecting microscope. Rust fungi are 'biotrophs' since they are obligate parasites (they need a living host). Infection leads to a physical association in which haustoria (feeding structures) invade living cells to obtain nutrients but do not immediately destroy them. Infections are usually local and the damage to the host results from the presence of many infections. Plants are weakened because nutrients and water are redirected toward the growth and reproduction of the fungus. Invaded cells remain alive and active until the parasite reproduces by developing spores.
5. Use the table on p. 28 to record disease reaction for each host isolate/pathogen isolate combination. Reactions may range from highly susceptible (large sporulating pustules) to highly resistant (tiny chlorotic flecks only), with intermediate levels (Figure 12 a, b, c). More precise evaluations may be made using a subjective visual scale of 0-4 or 0-9, 0 being the most resistant. For race identification, reactions are of two types: high (susceptible host/virulent pathogen) and low (resistant host/avirulent pathogen). Intermediate reactions may be difficult to rate, but are considered resistant (low), since any reduction in spore production, chlorosis or necrosis implies less disease development and reduces the rate of disease buildup.

Rust races are sequentially designated using code numbers and a dichotomous key or an avirulence/virulence formula. The code or race number relates only to the set or host group used. An earlier standard wheat set used for race identification was discarded following the development of isolines. No new standard set has been developed or widely used. At present, an avirulence/virulence formula is used to characterize each rust culture. An example would be Lr 1, 9, 16, 24, 26 /2a, 2c, and 3, which indicates that isolines Lr 1, 9, 16, 24, and 26 are resistant and isolines Lr 2a, 2c, and 3 are susceptible to this rust isolate. Conversely, the isolate is avirulent to isolines Lr 1, 9, 16, 24, and 26 and virulent to isolines Lr 2a, 2c, and 3. It represents a race different from a culture that is determined to be Lr 2a, 2c, 9, 24, 26/1, 3, 16.

R.A. McIntosh

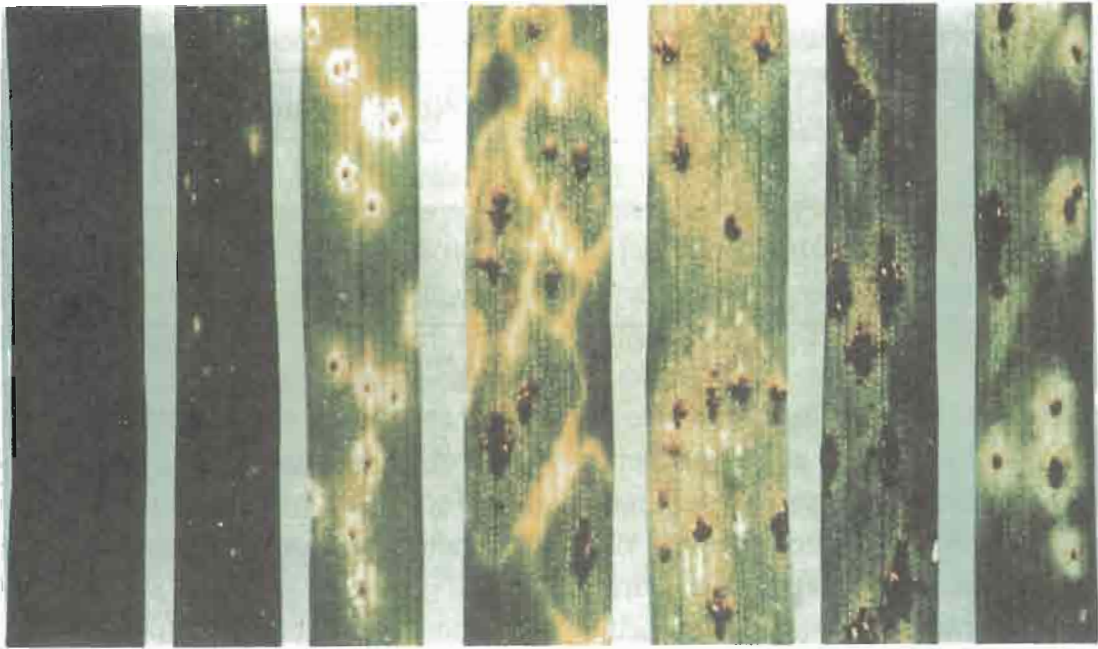

0 ; 1 2 3 4 X

a. Stem rust (*Puccinia graminis* f. sp. *tritici*)

R.P. Singh



0 ; 1 2 3 4 X

b. Leaf rust (*Puccinia recondita* f. sp. *tritici*)

R.W. Stubbs



c. Stripe rust (*Puccinia striiformis* f. sp. *tritici*)

Figure 12. Evaluation scales for rusts on wheat seedlings under greenhouse conditions.

Reactions of eight wheat isolines to two leaf rust isolates.

	Wheat isolate							
	Lr1	Lr2a	Lr2c	Lr3	Lr9	Lr16	Lr24	Lr26
Rust isolate A								
Rust isolate B								

Questions

1. How did the two fungal cultures differ from each other on each wheat isolate?
2. How did the wheat isolines differ from each other in this test?
3. If you were recommending sources of resistance to a wheat breeder, which of these genes would you recommend? Would you need additional information to make a useful recommendation? Explain.
4. Would any of these genes by itself be useful to a wheat breeder?
5. Would genetic recombinations of these resistances be useful?
6. Why is national or regional rust race monitoring useful to a wheat breeder working on developing resistant cultivars?
7. Besides wheat breeding, can you think of other areas where the information from a large scale rust race survey might be useful?

Bibliography

- Agrios, G.N. 1978. *Plant Pathology* (second ed.). Academic Press, Orlando, FL. 703 pp. (Chapter 6, Genetics and plant disease).
- Hanson, C.H., Schafer, J.F., and Turnipseed, S.G. 1979. Genetic resistance for crop protection. Chapter 3.2 in: *Introduction to Crop Protection*. W.B. Ennis, Jr., ed. American Society of Agronomy. Madison, WI. 524 pp.
- Kenaga, C.B. 1974. *Principles of Phytopathology* (second ed.). Waveland Press, Prospect Heights, IL. 402 pp. (Chapter 18, Disease control-breeding for resistance).
- Wiese, M.V. 1987. *Compendium of Wheat Diseases* (second ed.). American Phytopathological Society, ST. Paul, MN. pp. 37-42.

Smuts and bunts

Several genera of the class Basidiomycetes are included under the general names of smuts and bunts. Smuts and bunts are obligate pathogens that can remain dormant in the soil for long periods of time. This group of fungi is widely known because the symptoms they produce are very easy to recognize: they sporulate (produce brown or black spores) primarily in the grain, inflorescence, leaves, and stems. They attack cereals (wheat, barley, oats, maize, rice, etc.) and other economically important crops (potato, sugar cane, onion, etc.).

One of their most important taxonomic characteristics is that teliospores are produced individually, in pairs or in groups. Also important are teliospore size, color, and morphology; the presence and location of sterile cells; the sporulation site and the host.

In contrast to the rusts, fertilization takes place through the joining of the fungi's compatible propagules. Smuts and bunts that affect wheat are *Tilletia caries* and *T. foetida*, causal agents of common bunt; *Tilletia controversa*, causal agent of dwarf bunt; *Tilletia indica*, causal agent of Karnal bunt; *Ustilago tritici*, causal agent of loose smut; and *Urocystis agropyri*, causal agent of flag smut.

Identifying loose smut and Karnal bunt

The following is a description of how to do a germination test on teliospores (spores) to identify the smuts and bunts.

Loose smut. Take infected spike samples, put them in a container with water + Tween 20 or another surfactant, and shake. Use one drop of Tween per liter of water, and shake gently until it dilutes. Strain the spore suspension through a 60 μm mesh or smaller to retain large particles (teliospores measure 5-9 μm in diameter). Centrifuge at 3000 rpm to concentrate teliospores at the base of the test tube and discard the supernatant.

Prepare a sodium hypochlorite and water (1:9, v:v) solution. Add the solution to the test tube containing teliospores for surface sterilization, shake, centrifuge, and discard the supernatant. Add sterile water to the test tube to remove the sodium hypochlorite, shake, centrifuge, and discard the supernatant; add more sterile water and repeat once more.

Using a sterile syringe or a pipette, transfer teliospores to a Petri plate containing 1.5-2% agar (15-20 g agar per liter of water). Incubate plates at laboratory temperature (18-22°C). Seven days later, examine the plates and take notes on teliospore germination.

Karnal bunt. In the case of *Tilletia indica*, take infected grains and follow the same method described for *Ustilago tritici*. To obtain better germination, teliospores are kept in the water-Tween solution for 24 h before surface sterilizing with sodium hypochlorite. A 60- μm mesh is used to strain the solution because teliospores measure 22-49 μm in diameter.

Inoculation methods

There are several inoculation methods, but only one for loose smut and one for Karnal bunt are described here.

Loose smut: Dusting. Choose spikes at the flowering-anthesis stage and prepare them as for emasculation (cutting awns along with parts of the glumes, lemma, and palea). Cover them with glassine bags and dust with teliospores over the top (cut bag top with scissors and close with clips after dusting).

Karnal bunt: Boot inoculation. Colonies derived from germinated teliospores are transferred to a nutrient-rich medium (like PDA) for multiplication. Use the following process: Check that there is no contamination on plates containing germinating teliospores. Cut small pieces of agar containing germinating teliospores using a sterile (by flaming) spatula and transfer them to Petri plates containing PDA; cover the plates, turn them over (the fungus will sporulate downwards), and wait 4-6 days for colonies to develop. Add sterile water and scrape with a sterile spatula; inoculate more PDA plates using a sterile syringe or a pipette, then wait 5-7 days for the fungus to cover the medium completely.

After that time, add water, scrape, and strain through cheesecloth (to remove any agar or hyphae aggregates that might clog the needles during inoculation). After scraping about 15 plates, calculate the initial propagule concentration per milliliter using a haemocytometer and add the necessary water (10,000/ml). During inoculation inject 1 ml of that concentration into the boot.

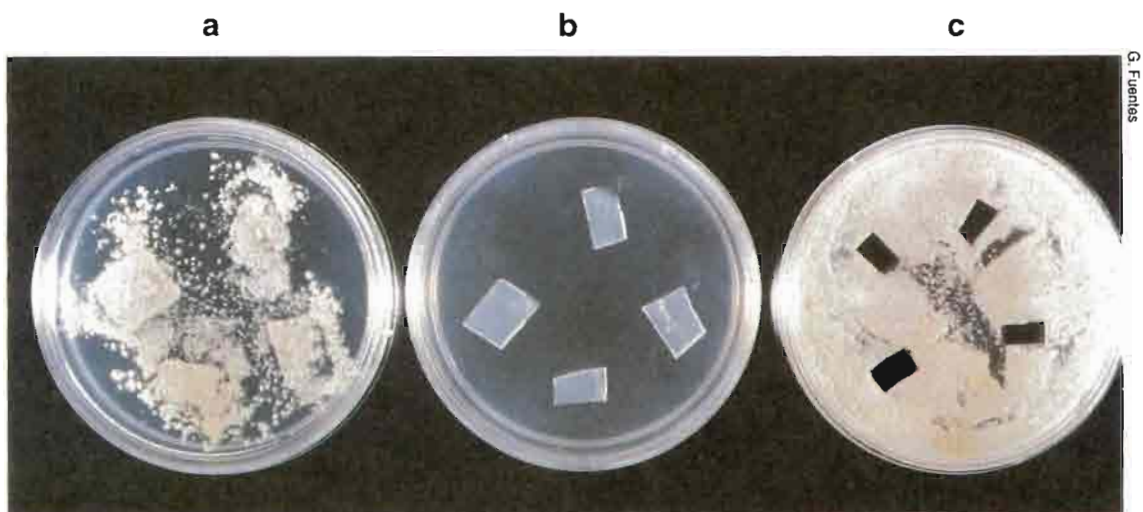

Figure 13 a. Fungal cultures and cuts on PDA. b. Inverted colony cuts initiating growth. c. Inoculum development and multiplication.

Introduction

The Ascomycetes comprise several thousand species that can be classified as being anywhere from strictly saprophytic to obligate parasites of higher plants. There are obligate parasites that attack and can severely damage small grain cereals.

The life cycle of the Ascomycetes has two phases: the asexual and sexual. During the first, the fungus gives rise to conidiophores, which are structures that generate asexual spores and conidia. Conidiophores can be born individually or in groups, directly from the host or in fruiting bodies known as pycnidia or acervuli. From the phytopathological point of view, this phase is very important because it is repeated during the crop cycle, and conidia can infect leaves, stems, spikes, as well as grains.

The fusion of two compatible nuclei takes place during the second phase, and as a result, fruiting bodies (perithecia, cleistothecia or apothecia) are formed. Fruiting bodies can withstand unfavorable humidity and temperature conditions in the absence of a host. Asci are produced in these fruiting bodies and become active at the beginning of a new crop cycle. This is the overwintering stage, although most asci and ascospores are not formed or do not mature until late winter or early spring. Therefore, the fungus can also overwinter as mycelium and sometimes as conidia.

The mycelium of the Ascomycetes is made up of well-developed, thick or thin hyphae, profusely branched and divided by simple septa. Pathogens in this group of fungi induce important cereal diseases such as foliar blights caused by *Helminthosporium* and *Septoria* spp.

Identification of spot blotch caused by *Helminthosporium sativum*

Spot blotch caused by *H. sativum* appears from the onset of foliage development, and multiplies primarily on leaves after heading. Since the fungus can attack the crown, roots, node, leaf sheaths, ears and kernels, it is considered an important pathogen especially in the subtropics, where optimum environmental conditions (high temperature and high humidity) are found.

This fungus produces its asexual reproductive structures consisting of conidia-bearing conidiophores on leaves and other parts of the plant. The isolation of *H. sativum* is simple, because in general it grows readily on PDA, or even in just a moist chamber. The sexual phase is not frequently found in nature, and has only been described under the agroecological conditions of Zambia.

Symptoms and isolation of the fungus

Place a sample on the diagnostic sheet and describe the symptoms you see. Prepare 1% sodium hypochlorite (1 ml sodium hypochlorite in 99 ml sterile distilled water; if available, add one drop of Tween 20 to reduce surface tension). Pour the solution and the sterile distilled water into separate Petri plates. Cut small pieces of leaves showing incipient lesions and place them in hypochlorite for 1 minute. Dip the tip of the forceps in alcohol and flame it over a burner for a few seconds. With the forceps transfer leaf pieces to sterile water and rinse off the excess hypochlorite; allow them to dry on sterile filter paper. Under sterile conditions (in a microvoid and/or an area disinfected with alcohol or hypochlorite), plate the pieces in an orderly fashion on PDA (5-7 pieces per plate).

At the same time, incubate a sample in a moist chamber for 3-7 days. Make sure that the filter paper is always wet, adding water if necessary. After this period, there should be substantial fungal growth. Describe characteristics of the colonies. Take a tiny portion of the fungal growth and prepare a temporary mount in water; observe under the compound microscope using the objective with the lowest magnification. For fine details, use higher magnification. Draw and describe the structures observed: mycelium, conidiophores, conidia, etc. Search in the literature to compare the conditions that favor fungal attacks on roots and on leaves.

Identification of tan spot caused by *Helminthosporium tritici-repentis*

Tan spot (also known as leaf blight or eye spot), caused by *Helminthosporium tritici-repentis*, is a disease that attacks wheat, triticale and some grasses. Symptoms appear as necrotic lesions with a chlorotic halo that vary in size depending on disease severity; lesions may coalesce and destroy the whole leaf. An important diagnostic feature is a dark spot in the middle of the lesion. This feature is not exclusive of tan spot, however, as it also occurs on lesions caused by *H. sativum* and *Septoria nodorum*. For this reason, a final diagnosis can only be made by observing fungal structures under the compound microscope.

The causal agent does not grow or sporulate easily on culture media because it often initiates the formation of sexual structures (pseudothecia), although they do not mature. Nevertheless, it has been observed that if 5-7 day-old colonies are covered with sterile water and scraped, sporulation is induced within 48 h.

The sexual phase has been reported in many parts of the world. Formation of sexual structures seems to depend on environmental conditions during winter and early spring. They are generally found on crop residues left in the field after harvest.

Symptoms and isolation of the fungus

Select leaves showing typical lesions for your diagnostic sheet and describe symptoms. Cut small pieces of leaf containing incipient lesions; surface disinfect them in 1% sodium hypochlorite during 1-2 min. Rinse in sterile water and let them dry on sterile filter paper. Put five pieces per Petri plate on 30% V-8 medium (very efficient for isolating and producing spores of this fungus).

Incubate plates at 20-22°C under near ultraviolet fluorescent lights for 5-7 days using a 10 h-14 h light-darkness regime (essential for sporulation). To stimulate conidia production, add sterile water and scrape the surface of 5-6 day-old colonies with a sterile spatula. Remove inoculum and continue incubation of the plates for an additional 48 h. Past this time, make preparations and observe under the compound microscope. Describe colony characteristics. Describe and draw the structures observed.

Identification of *Helminthosporium* spp., causal agents of barley net and spot blotch

Barley net blotch caused by *Helminthosporium teres* f. sp. *teres* is common in cold, humid areas wherever barley is grown. A dark spot develops into a net-like pattern having transversal and longitudinal bands. It usually occurs on leaves, although on very susceptible cultivars it may attack the spike and reach the kernels.

Helminthosporium teres f. sp. *maculata* and/or *H. sativum* can cause another blotch that produces symptoms very similar to those caused by *H. sativum*. These two pathogens can be differentiated by observing their conidia under the microscope.

Helminthosporium teres f. sp. *teres* and *H. teres* f. sp. *maculata* show the same morphological development on artificial media; however, they are capable of inducing completely different symptoms. The sexual phase is often found in crop residues during the winter cycle.

Symptoms and isolation of the fungus

Collect a sample of each disease for the diagnostic sheet, and describe their respective symptoms. Cut small pieces of diseased tissue from each sample, surface sterilize them in 3% sodium hypochlorite for 1 min, and rinse in sterile water. Dry them on sterile filter paper and plate five pieces from each sample on V-8 medium (15%). Incubate at 20-22°C for 5-7 days under alternating periods of light and darkness; *H. teres* will not sporulate if those conditions are not met. Observe samples under the microscope, and describe the shape and color of colonies. Draw the observed structures, and differentiate conidia of the various *Helminthosporium* species by shape and size.

**Identification of leaf blotch caused by
Mycosphaerella graminicola (*Septoria tritici*)
and glume blotch caused by
Leptosphaeria nodorum (*Septoria nodorum*)**

Wheat is attacked by several species of the genus *Septoria*. Among the most important are *S. tritici* and *S. nodorum*. The first, causal agent of leaf blotch, occurs in regions with high rainfall and high relative humidity, and temperatures between 18 and 24°C. This blotch is identified by the presence of black asexual bodies (pycnidia) formed by the fungus, which extend from both sides of the leaf epidermis and are distributed in parallel lines. Inside the pycnidia there are long, thin pycnidiospores, which, when mature, come out of the pycnidia through an ostiole (pycnidial aperture) if favorable moist conditions occur.

Septoria nodorum is present in almost the same conditions as *S. tritici*, but needs more temperate conditions. In wheat, it may attack all plant parts above the ground, particularly the glumes, nodes, internodes and leaves. In contrast to *S. tritici*, *S. nodorum* pycnidia are black to pinkish in color and immersed in the epidermal tissue at random. Pycnidiospores are small, cylindrical and transparent, with 0-3 septa.

Although in both cases the sexual phase often occurs at the end of the crop cycle, identification is difficult because pycnidia are similar to perithecia. Proper identification can be only done using special laboratory techniques. Both species may be isolated and cultivated on specific artificial media.

Symptoms and isolation of the fungus

Collect a sample of each disease for the diagnostic sheet, and describe the symptoms. Attach diseased leaf segments to a glass slide with the pycnidia facing up. Place the slide in a Petri dish with filter paper saturated with sterile water to make a moist chamber; seal the plates and place them under the light at a distance of 15-20 cm. One or two hours later, observe the Petri dish (with its cover still on), under the stereoscope; there should be exudates oozing through the pycnidial ostiole. *Septoria tritici* exudate is grayish white, while *S. nodorum* exudate is pinkish. With a sterile toothpick, near a burner, take a drop of exudate and put it on the plate containing the specific medium. Incubate the plate for 6-8 days. Describe colony characteristics.

Cut fine pycnidial pieces, make slide preparations and observe them under the microscope; describe and draw the type of pycnidiospore produced by each species.

Identification of head scab of wheat caused by *Fusarium* spp.

Head scab of wheat is a disease that appears when heading starts, although the flowering stage is the most susceptible. In Mexico, *Fusarium graminearum* is the most common species, although *F. culmorum*, *F. nivale*, *F. equiseti* and *F. avenaceum* are also present.

Identifying *Fusarium* spp. is not easy because their differences are not conspicuous. Although PDA works well when used for isolation and identification, there are other specific media for isolating this genus, such as corn meal agar, which is commercially available, and PCNB. These media are useful for inducing sporulation and for isolation, and problems with saprophytes can be avoided. Criteria used for identifying *Fusarium* species are the presence and shape of microconidia, macroconidia and chlamydospores (for more details, see 'Symptoms and isolation of *Fusarium*' on p. 40). The most commonly used taxonomic keys are those of Booth and Toussoun and Nelson (references in the same section).

Spikes affected by the pathogen show different colors ranging from pinkish- white to orange. The sexual phase develops on the glumes at the end of the crop cycle in some areas and overwinters on crop residues.

Symptoms and isolation of the fungus

Attach an infected spike onto the diagnostic sheet and describe disease symptoms. Use sterile forceps to carefully separate floral structures and take kernels from infected spikelets, especially those showing mycelium, and directly inoculate PDA plates. Incubate plates for 5-7 days under near ultraviolet light (to stimulate development of the asexual phase). At the end of this period, observe samples under the microscope and try to identify the species. If there is contamination, try to purify the culture by taking a small piece from the edge of the desired colony, transferring it to another PDA plate and incubating for 5-7 days.

To obtain 100% pure cultures, use a conidial suspension to make serial dilutions on water-agar. Within 12 hours, isolate individual germinating conidia with a dissecting needle. Describe colony characteristics. Draw and describe the structures seen under the microscope.

Inoculum preparation and field inoculation

There are two main methods used for evaluating germplasm for scab resistance: inoculation of individual spikes or bulk inoculation.

Scrape fungal propagules from several plates containing pure cultures of the fungus as follows: add sterile distilled water to the plates and scrape with a spatula or a scalpel. Strain the suspension through cheesecloth and use the haemocytometer to adjust to a concentration of 50,000 spores per ml. If possible, prepare inoculum just before inoculating; however, inoculum remains infectious for up to 36 h if maintained at 4-5°C.

Inoculation of individual spikes (cotton method). Select and label 10 spikes per line. Anthers should be just starting to emerge from florets. Cut the awns to facilitate bagging. Soak a small piece of cotton in the spore suspension; open the glumes and inoculate the middle portion of the spike by placing a tiny portion of the soaked cotton on each side. Cover with a glassine bag.

Bulk inoculation. To evaluate large numbers of advanced lines or segregating populations, spray the inoculum from a distance of 10-15 cm, until spikes are covered uniformly. Inoculations should be carried out at least three times a week if environmental conditions are less than optimal. Inoculation should be done when 5-10% of anthers in the plot have emerged.

Inoculated materials are evaluated 30-40 days after inoculation, at the end of grainfilling. At this stage spikes are still green and there is a strong contrast between the color of healthy spikes (green) and infected spikes (yellow). Evaluation can be done as a percentage, based on the number of infected spikes compared to the total number of spikes.

Introduction

There are many fungi in nature which, despite producing septate mycelia, rarely reproduce sexually. For this reason, they are termed Imperfect Fungi or Deuteromycetes. Most are either saprobes or weak parasites of plants, animals and man. Some are parasitic on other fungi and nematodes.

Deuteromycetes survive perfectly well in nature without sexual reproduction. Asexual reproduction is initiated from a stroma that generates conidia, from conidia that develop without special hyphae (conidiophores), or from fruiting bodies such as pycnidia, acervuli, sporodochia and synnemata.

Identification of black point caused by *Alternaria alternata*, *A. triticina*, and/or *Helminthosporium sativum*

Black point, a blackening of the embryo end of the seed, may be induced by any of three species: *Alternaria alternata*, *A. triticina*, and/or *Helminthosporium sativum*. Identifying which of the three is the cause of the damage requires isolating a sample on a culture medium and observing it under the microscope.

Symptoms and isolation of the pathogen

Collect a diseased sample for the diagnostic sheet and describe symptoms. Place 3% sodium hypochlorite and sterile water in separate Petri plates; sterilize kernels by placing in sodium hypochlorite for 1 min. With sterile forceps transfer kernels to the sterile water to rinse off excess hypochlorite. Dry off excess water on a paper towel to reduce the possibility of contaminant bacteria. Then place five kernels from Cd. Obregon and five from Poza Rica on different PDA plates.

Incubate the plates for 5-7 days, make slide preparations and observe under the microscope. Describe the color and shape of each colony. Draw the structures observed on each isolate. Describe the shape, number of septa and other conidial characteristics observed on each isolate. Search the literature for the conditions that favor damage by each of the different pathogens.

Identification of *Rhynchosporium secalis*, causal agent of barley scald

Scald (causal agent: *Rhynchosporium secalis*) is one of the most important diseases of barley in cold and humid areas, as well as in tropical highlands where there is high rainfall and temperatures are low because of the altitude. This disease primarily affects

the leaves, but it can also affect the glumes, awns and grains. Symptoms in the field are easily recognized because they start as oval, elongated or elliptical lesions, with dark-brown or reddish edges, and gray or yellowish-brown centers.

Isolation and culture of the fungus are somewhat difficult. Due to its slow growth rate, the first signs of growth appear after 14 days of incubation. Therefore, any growth appearing before then should be eliminated because it is probably a contaminant. For quick identification, make direct preparations from diseased tissue showing conidia and observe under the microscope. However, if the objective is to isolate in order to collect virulences for testing barley genotypes for resistance, the following method is recommended.

Symptoms and isolation of the pathogen

Collect barley leaves with scald symptoms for the diagnostic sheet and describe the symptoms observed.

Direct identification of diseased tissue. With a razor blade or scalpel, scrape the leaf surface of clear lesions, and make a preparation. Observe the specimen under the microscope; draw and describe the fungal structures.

Isolation on lima bean agar (LBA) and multiplication. Cut small pieces of diseased tissue showing young lesions, preferably grayish-green lesions with no necrotic margins. Dip in 70% ethyl alcohol for 15-20 seconds and transfer to sodium hypochlorite (commercial grade, 5.25% in weight) diluted in water (1:9). Soak (making sure tissues are completely submerged) in the hypochlorite for 90 seconds. (Soaking time is important: if samples are soaked for only 60 seconds, they will show a lot of contamination in the fungal cultures; if samples are soaked for two minutes or longer, the fungus will be eliminated.) Transfer the pieces of tissue to Petri plates containing LBA.

Components of LBA medium:

Commercial LBA	23 g
(8 g lima bean infusion, 15 g agar)	
Pure agar	5 g
Distilled water	1000 ml

Add 5 g pure agar to the commercial LBA; mix with distilled water.

Incubate Petri plates at 18-20°C. Schein and Kerelo (1956) indicate that growth can be observed after 5-7 days' incubation. However, in our experience 10-14 days are required. Growth of the fungus on LBA is slow, but the small colonies produced are

pure. To obtain a large number of spores per culture, use the zigzag culture technique to inoculate tubes or Petri plates as follows.

Pick up the incipient growth with a sterile needle and dilute in 1 ml sterile water; shake vigorously to obtain a homogeneous suspension. Take a small amount with a previously flamed and cooled Pasteur pipette and deposit it on the culture medium. Bend the tip of the pipette with the flame, let it cool, then use it to distribute the inoculum smoothly and as uniformly as possible on the culture medium. After eight days, the culture will have a yeast-like appearance and contain 30 million spores or more. All colonies obtained on this medium are pink, which contrasts with the black or brown color of colonies on other culture media.

Reference

Schein R.D., and J.W. Kerelo. 1956. Culturing *Rhynchosporium secalis*. Plant Disease Reporter 4(9):814-815.

Introduction

Soil pathogens produce diseases that inhibit development of the plant's root system and/or destroy it. It is difficult to identify all the potential problems soil pathogens can cause; however, it is possible to group them according to the climatic zones where they are prevalent. Thus, *Helminthosporium*, *Fusarium*, and *Pythium* are important in cool climates, *Sclerotium rolfsii* in subtropical regions, and *Gaeumannomyces graminis* in cold, rainy areas.

In general these fungi cause such symptoms as poor plant growth, fewer tillers, and early maturity (white heads). Also, patches of diseased plants can be observed in the field.

Symptoms caused by *Fusarium* and *Helminthosporium*

Fusarium and *Helminthosporium* can be found in many places due to their wide host range and temperature adaptation. Both fungi interfere with plant establishment and pre- and post-emergence of the roots, particularly if soil temperature is high (25-30°C) at planting. Moist soils are more conducive to *Helminthosporium* damage, while dry soils favor *Fusarium*, especially when plants reach maturity under water stress.

When the wheat crop reaches maturity, white heads occur randomly or in irregular patches in the field. If subcrown internodes of plants with white heads are light to dark brown, it is a sign of *Fusarium* infection. The development of white heads is closely related to drought stress in cool climates; if drought stress increases during plant maturity, it is likely that white heads will be observed in areas where the pathogen is present.

The most characteristic symptoms of *Helminthosporium* are brown to black lesions on the internode below the crown, which become more severe as plants grow. As long as the subcrowns remain intact, changes in severity can be observed during the growth cycle. *Helminthosporium* can also cause white head symptoms when plants reach maturity, just as *Fusarium* and *Gaeumannomyces* (take-all) do.

Symptoms and isolation of *Fusarium*

PDA can be used as a general culture medium for isolating *Fusarium*, but certain types of studies require selective media. The preparation of *Fusarium* selective medium for about 40-50 Petri plates (15 X 100 mm) is as follows:

Components:

Deionized water	1000 ml
Agar	20.0 g
Peptone	15.0 g
Monobasic potassium phosphate (KH ₂ PO ₄)	1.0 g
Magnesium sulfate (MgSO ₄ -7H ₂ O)	0.5 g

Mix, dissolve, and sterilize. Cool medium to 45-50°C, then add:

PCNB (pentachlorobenzene; Terraclor)	0.5 g
Bacto-oxgall	1.0 g
Streptomycin sulfate	0.1 g
Chlorotetracycline-HCL	0.05 g

Streptomycin sulfate is dissolved in 3-5 ml of 95% ethyl alcohol; the other ingredients are added dry. The medium should be shaken gently for 2-3 minutes, taking care not to let bubbles form.

Procedure: Select tissues of plants collected in the field to make isolates. Observe the discolored tissue under the stereoscope. Sometimes it is possible to see mycelium growing on and in the tissue of the first internode. In this case, tissue should not be surface sterilized.

Remove leaf sheaths with forceps as aseptically as possible (do not touch tissue with your fingers). Flame scissors, then cut the internode into small segments (0.5 cm or smaller) and place 5-10 pieces in a Petri plate, either on PDA or the selective medium. After a 3-5 day incubation period, check development of *Fusarium*. A pure white to reddish colony with a yellow shadow can be observed, and the mycelial growth is aerial and hairy. Purify the subcultures at this stage and place on the same culture medium. Examine the subcultures under the microscope to determine if they are pure, so that they can be used for further identification and storage.

To identify *Fusarium* species, it is necessary to work with cultures derived from single conidia. However, in studies dealing with plant resistance, a mixture of cultures should be used to maintain broad genetic diversity in the inoculum. Identification work is done in the laboratory using previously isolated and purified cultures that have not been derived from a single spore (i.e., non monosporic). **Host resistance should never be evaluated using only isolates derived from single conidia.**

CMA and PDA are the media of choice for this work, as well as for initiating cultures of specimens kept in storage. Pieces of these cultures can be used to infect wheat-seed medium for pathogenicity tests or to increase inoculum for field tests.

To identify *Fusarium* species, isolates should be made to sporulate under standard conditions using one culture medium. Tousson and Nelson recommend immersing carnation leaf pieces in water, then placing 4-5 pieces on the surface of 2% water agar at points equidistant from the center, where a piece of the growing fungal culture is placed. Repeat the procedure on several plates. The plates are sealed and incubated at room temperature (25°C) using alternating cycles of 12 h fluorescent light/12 h darkness.

After 6-7 days, the plates should be examined for sporulation. Once sporulation has started, observations and notes should be taken about the presence of microconidia, macroconidia, chlamydospores, etc. Based on the morphology of the observed structures and using the *Fusarium* taxonomic keys, start reducing the number of species that could be present. The following characteristics are important for using these keys correctly:

- a) Septate mycelium.
- b) Macroconidia: They are large and have more than two septa. Observe the apical cell, basal cell (foot cell) and number of septa. The shape of the apical and basal cells is important. How macroconidia are borne on the conidiophore may also be important.
- c) Microconidia: They are small with 1-2 cells. Not all *Fusarium* species produce microconidia, so their presence or absence is important.
- d) Chlamydospores: They are latent, thick-walled spores produced by hyphae and conidia. Their presence or absence is important. Generally, they are produced by cultures more than a week old.

The examination process should be slowly and carefully done. Select 1-4 isolates representative of different type colonies (i.e., white or multi-colored colonies). Look for macroconidia and examine them, and determine the presence or absence of microconidia. Once you have become familiar with the species you are studying, it will be easier to classify the rest of the isolates.

References

- Booth, C. 1977. *Fusarium*. Laboratory Guide to the Identification of the Major Species. Commonwealth Mycological Institute. Kew, Surrey England. 58 pp.
- Booth, C. 1977. The Genus *Fusarium*. Commonwealth Mycological Institute. Kew, Surrey, England. 237 pp.
- Burgess, L.W., C.M. Liddell, and B.A. Summerell. 1988. Laboratory manual for *Fusarium* research. 2nd. edition. *Fusarium* Research Laboratory Department of Plant Pathology and Australia Entomology. The University of Sydney.
- Francis, R.G., and L.W. Burges. 1977. Characteristics of two populations of *Fusarium roseum* 'graminearum' in Eastern Australia. *Trans. Br. Mycol. Soc.* 68:421-427.
- Nelson, P.E., T.A. Tousson, and W.F.O. Marasas. 1983. *Fusarium* species. University Park and London: The Pennsylvania State University Press. 193 pp.
- Tousson, T.A., and P.E. Nelson. 1976. *Fusarium*. A pictorial guide to the identification of *Fusarium* species according to the taxonomic system of Synder and Hansen. 2nd. ed. University Park and London: The Pennsylvania State University Press. 43 pp.
- Zillinsky, F.J. 1984. Common Diseases of Small Grain Cereals: A guide to identification. Mexico D.F.: CIMMYT. 141 pp.

Isolation and identification of *Helminthosporium*

In general, it is easier to isolate *Helminthosporium* than *Fusarium*. PDA can be used for general purposes, but selective media such as Czapek's modified broth should be the medium of choice for specific studies.

Components:

Deionized water	1000 ml
Czapek-Dox broth	35 g
Agar	15 g

After mixing and sterilizing the medium, let it cool to 46-50°C and then add:

Streptomycin sulfate	0.1 g
Benomyl (Benlate 50 WP)	0.004 to 0.008 g

Czapek's broth:

Sacarose	30.0 g
Sodium nitrate (NaNO ₃)	3.0 g
Dibasic potassium phosphate (K ₂ HPO ₄ -3H ₂ O)	1.0 g
Magnesium sulfate (MgSO ₄ -7H ₂ O)	0.5 g
Potassium chloride (KCl)	0.5 g
Ferrous sulfate (FeSO ₄ -7H ₂ O)	0.01 g
Distilled water	1000 ml

Growth of *H. sativum* is usually visible as a white micelial front that moves forward, leaving a dark area. To confirm identification, cultures must be microscopically examined because *Alternaria* spp. show similar growth characteristics on the medium, although their conidia are clearly different and produced in chains.

Helminthosporium spiciferum can also be isolated by this method; its growth, of a dark-hairy discolored type, is quite distinctive. *Helminthosporium spiciferum* produces conidia on verticils at the apex of the conidiophores. Conidia are much smaller than those of *H. sativum*, which are produced individually. With some experience, it is easy to detect these differences with the aid of a stereoscope.

Procedure: To isolate fungi from plant tissue or the internodes below the crown, use the following procedure:

Wash all plant material before bringing it into the laboratory. Cut the internodes below the crown and the seminal roots. Surface disinfect samples with a 1:1 ethyl alcohol:5% sodium hypochlorite solution for 1 min. Rinse in sterile water twice and dry on paper towels. Plate five pieces in the medium and incubate at 22 °C for five days.

References

- Luttrell, E.S. 1964. Systematics of *Helminthosporium* and related genera. *Mycologia* 56:119-132.
- Shoemaker, R.A. 1959. Nomenclature of *Drechslera* and *Bipolaris*, grass parasites segregated for '*Helminthosporium*'. *Can. J. Bot.* 37:879-887.
- Stack, R.W. 1977. A simple selective medium for isolation of *Cochliobolus sativum* from diseased cereal crowns and roots. *Pl. Dis. Rep.* 61:119-522.

Symptoms of *Pythium*, *Gaeumannomyces* and *Rhizoctonia*

Pythium

Many *Pythium* species attack cereals. Damage in the field can be seen as stunting and yellowing of plants. Although easy to observe, these symptoms are difficult to distinguish from nitrogen deficiency. To determine the cause of the observed symptoms, examine the root system; watery, atrophied brown-reddish roots indicate *Pythium*. Oospores can be detected in root tissue after staining with lacto-fuchsin (0.1 g fuchsin acid /100 ml lactic acid).

***Gaeumannomyces graminis* var. *tritici* (syn. *Ophiobolus graminis*), take-all**

Since damage by this fungus is reduced when soil temperature goes above 27°C, it may not be important in the tropics. However, it is very important in areas with rather low

soil temperatures (10-15°C). In the field, diseased plants (white heads) appear in irregular patches similar to those caused by *Fusarium*. However, in contrast with *Fusarium* symptoms, the lowest internodes and roots of plants affected by the take-all fungus are shiny black in color. Also, a black mycelial network is present on the surface of infected roots.

Rhizoctonia

This fungus can cause blight and yellowing of seedlings, but in adult plants symptoms resemble those of *Helminthosporium* and *Fusarium*. Lesions in adult plants are sharp eyespots (strawbreaker) on the lower leaf sheaths that may weaken culms and lead to lodging.

Isolation of *Pythium*, *Gaeumannomyces* and *Rhizoctonia*

The technique described below works well for isolating *Pythium* and *Gaeumannomyces* from the wheat root system. It is also useful for isolating *Rhizoctonia* from wheat tissue.

This technique is based on using fungal traps which consist of infected roots or other plant tissues. For *Pythium*, it is best to use wheat roots collected in a field suspected to be infected with the fungus, regardless of whether symptoms are well defined. This condition is most often seen when plants reach maturity, and other pathogens and saprophytes may be present in the same lesion. It is difficult to isolate *Pythium* and *Gaeumannomyces* directly from infected roots.

Corn meal agar is used to isolate *Pythium* and *Gaeumannomyces*. To prepare CMA, mix 40 g corn meal in 1 L of water and keep at 50°C for one hour; strain through filter paper, add 15 g agar and sterilize. *Rhizoctonia* grows well on PDA.

Traps. Collect roots in the field, take them to the laboratory, and rinse them very carefully on sieves to remove soil particles and other debris. Place this material in pots half filled with sterile sand, and plant 4-6 wheat seeds on top of roots (Figure 14 a). Cover with about 2 cm of sterile sand. Irrigate pots and incubate them in the laboratory using additional light (12 hours of light). For *Rhizoctonia* temperature should be 20-25°C, 14-16°C for *Gaeumannomyces*, and 18-20°C for *Pythium*. Make sure pots are well drained, and add water as necessary.

Take seedlings from the pots 5-6 days after emergence (Figure 14 b). Remove roots very carefully from the soil so as to preserve the original root mass. Then wash by immersing slowly in water to obtain intact samples. If *Pythium* is present, infected roots will be

small and light brown in color. If *Rhizoctonia* is present, lesions are brown; they are black in the case of *Gaeumannomyces* (Figure 14 c).

Isolation may be done following one of two methods:

1. The complete root system is laid down gently on the medium in a plate. This method is generally used when few or no symptoms are visible.
2. When severe symptoms are present, individual root segments from infected material are cut and plated on a culture medium recommended for the suspected pathogens. Disinfection of plant material generally is not necessary when using this method. To avoid bacterial contamination, dry roots carefully before transferring to the medium.

The use of wheat seedlings as a selective medium facilitates the isolation of the most aggressive and virulent pathogen present in the plant tissue, and inhibits growth of weak pathogens and saprophytes. In both cases, inoculated plates should be incubated upside down. For *Pythium*, examination of plates should start after 24 h to avoid contamination. *Pythium* isolates generally produce one colony, 50-60 μm in diameter, after 24-48 h. Growth of *Pythium* on this medium is less conspicuous than *Fusarium* and is usually restricted, with little aerial development. Growth will be more visible if plates are observed through the bottom using refracted light. If a colony with the above described features develops after a 24-48 h incubation period, it will almost invariably be *Pythium*. Re-isolations should be done at this stage by taking mycelium from the

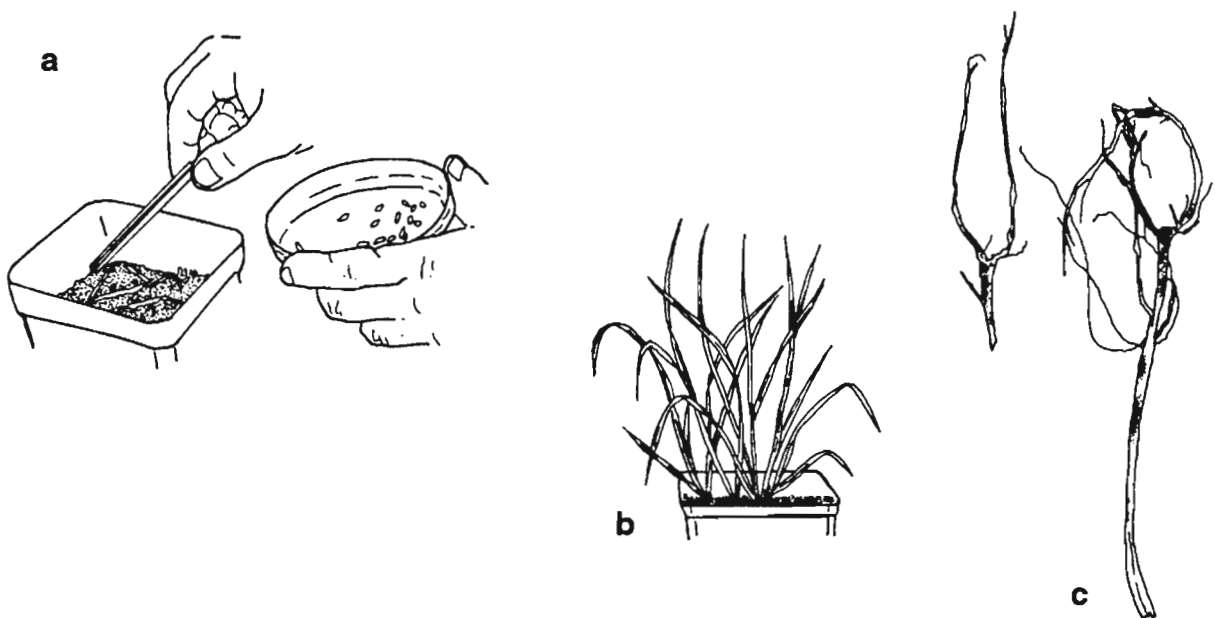

Figure 14 a, b, c. Steps for constructing a trap for isolating fungi that cause root rots.

edges of the colony to obtain pure cultures. *Fusarium*, *Gaeumannomyces*, *Helminthosporium* and /or *Rhizoctonia* usually take three or more days to produce colonies.

Compared with *Pythium*, the initial growth of *Gaeumannomyces* is very slow, taking several days to develop at this temperature. Cultures should be examined to get rid of contaminants.

Identification of *Pythium*

Taxonomy of *Pythium* species is generally based on a few distinctive morphological structures relating to the production of sporangia and oospores or conidia. The presence or absence, size, shape and number of these structures are greatly affected by the medium used as well as by temperature regime, age of the culture and other environmental factors used to induce their formation. The structures on which the identification of *Pythium* species is based are defined and described below.

Sporangia. Sac-shaped structures whose complete protoplasmic content is converted into motile, asexual spores called zoospores. The time required for sporangia formation in culture medium, as well as sporangial number and morphology, varies widely among species. Some are formed very quickly in agar medium, while others are formed only when the mycelium is submerged in water. *Pythium* basically produces three types of sporangia: globose, lobulate and filamentous. Species with filamentous sporangia generally produce zoospores only when submerged in water. Zoospores vary in size, shape, and position of the flagella. However, since they are very small, only extreme variations of the described morphological features are useful in taxonomy.

Conidia. Spherical, globose to ellipsoid structures, in most cases resembling sporangia. The only difference is that conidia do not produce zoospores.

Oogonium. Female gametangium containing one or more gametes. Oogonia are spherical, sub-spherical or ellipsoid, and may have spines or other protuberances. They can be terminal or intercalary, but most species have both. Temperature, media, and the length of time in the media are factors that affect size, shape, and the number of oogonia produced.

Antheridium. Male gametangium. Antheridia are probably the most difficult taxonomic feature to observe. The number of these structures may vary from one to more than 25 per oogonium. Depending on their position, they may be hypogenous (below the oogonium) or perigenous (beside the oogonium). They may be monoclynous in origin (antheridia are formed from any hyphal branch on an entirely different oogonial thallus).

Oospore. A sexual spore produced by the union of two morphologically different gametangia (oogonium and antheridium). Oospores are produced individually under normal conditions. The oospore may completely fill the oogonial cavity or the oosphere in which it is formed; in this case it is plerotic. If it does not fill the oogonial cavity or is free within it, it is aplerotic. Unfortunately, there are very few species which present one condition and not the other. Sometimes, the two conditions can be observed in the same Petri plate.

Method for inducing zoospore production

The fungus is cultured on corn meal agar for five days at 15°C. Small portions of the culture (3-5 mm) are transferred to test tubes containing sterile water and fresh leaves (2 cm) that have been boiled for 10 min in distilled, sterile water. After leaf infection (24 h), transfer the leaves to Petri plates and incubate at 18-20°C. Sporangia are generally produced after 24-36 h. In some cases, periodic water changes will stimulate zoospore production.

References

Frezzi, M.J. 1956. Especies de *Pythium* fitopatógenas identificadas en la República Argentina. Revista de Investigaciones Agrícolas. T.X. 2:197-241. Buenos Aires, Argentina.

Identification of *Gaeumannomyces*

Gaeumannomyces forms thick, black mycelium. Initially, radicles are brown in color but turn black within 10 days. At about this time, perithecia formation on roots, crown and lower sheaths starts.

Identification of *Rhizoctonia*

Rhizoctonia mycelium tends to branch at right angles and form septa near the branch bases. The fungus produces irregularly shaped sclerotia after one week on culture medium.

Identification of *Sclerotium rolfsii*

This fungus has a very wide host range and seriously affects some crops, especially in the tropics. It typically produces white mycelial growth on the surface of soil and plants. *Sclerotium rolfsii* produces sclerotia that are from white to dark brown in color and resemble mustard seeds. Sclerotia are very easy to observe on dying plants. To isolate this fungus, transfer mycelium or sclerotia to PDA with a sterile needle.

Introduction

Nematodes, frequently referred to as eelworms, are microscopic roundworms too small (0.3 to 5.0 μm) to be observed with the unaided eye. In the past, crop damage by nematodes was attributed to other causes, such as soil infertility or water stress. Additionally, no clear information on nematode pathogenicity was available.

Plant-parasitic nematodes are found all over the world, and roots of virtually all plants are infested by one or more forms. More than 5,000 species belonging to 200 genera are known to parasitize plants and can cause economic damage to crops.

Soil nematodes: Identification of parasitic and saprophytic species

Although nematode genera have distinctly different morphological characteristics, all pathogenic species possess a feeding apparatus known as a stylet that enables the nematode to penetrate plants and extract the nutrients it requires. The stylet is absent in saprophyte nematodes.

Ectoparasitic nematodes such as *Tylenchorhynchus*, *Helycotylenchus* and *Xiphinema* remain outside the host while feeding on its internal cells. The nematode uses the stylet to pierce the cells, retracts it after a brief feeding period and then repeats the process. In contrast to this type of feeding behavior, endoparasitic nematodes—including *Meloidogyne* and *Pratylenchus*—following penetration migrate into the root tissue, where they feed and complete their life cycle. Endoparasitic nematodes are considered more insidious parasites since they disrupt internal tissues during their migration and are in contact with the vascular system during feeding. A further complication with nematode attack is that their penetration can provide portals of entry for soilborne fungi and bacteria, thus creating secondary infections.

Important characteristics of parasitic nematodes, including the stylet, can be observed in Figure 15.

Sampling techniques

Diagnosis of a nematode problem requires identifying the pest in association with the diseased plant. Figure 16 shows different ways of taking soil and plant samples in areas presenting these problems.

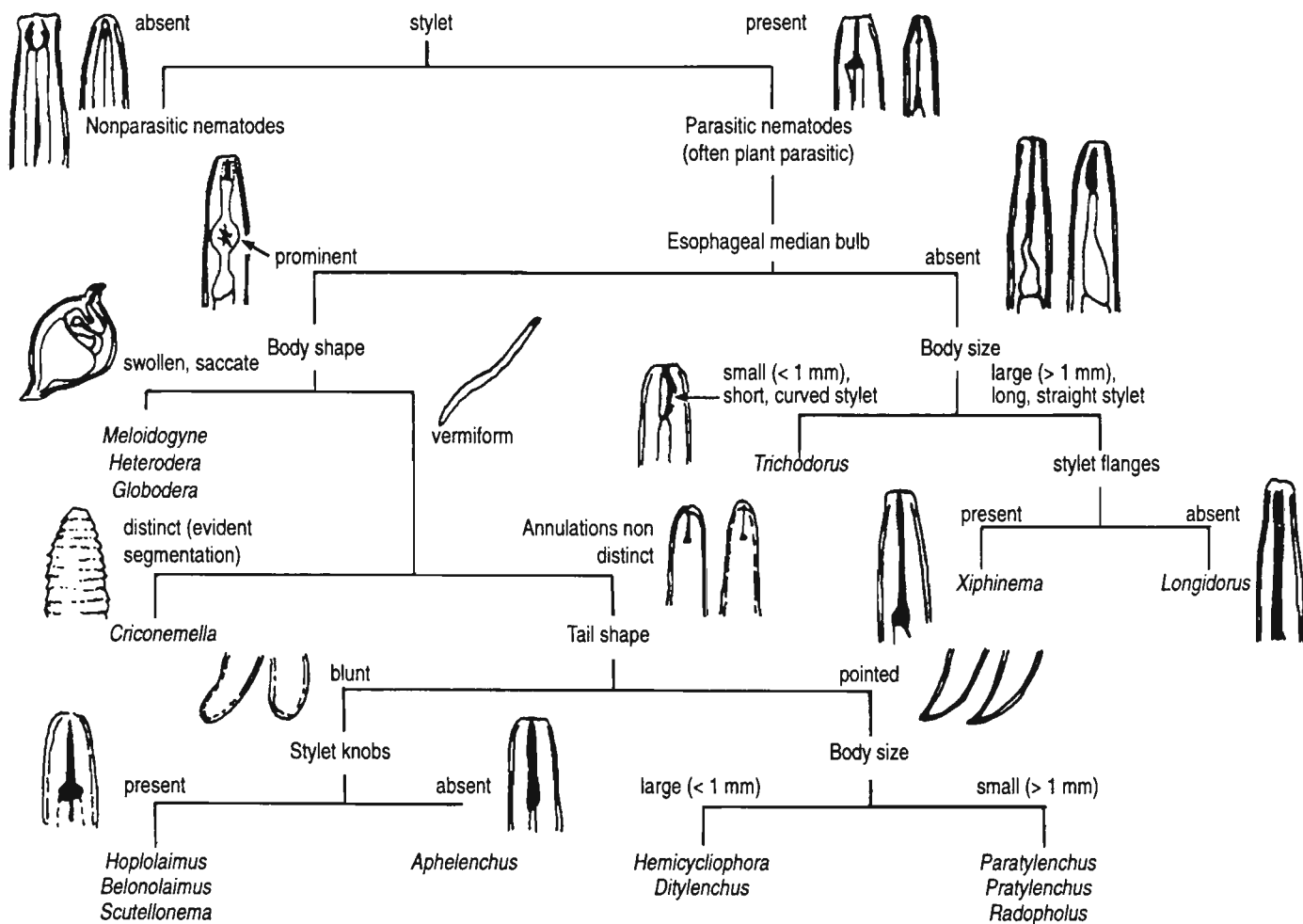

Figure 15. Key for the identification of some plant parasitic nematodes.

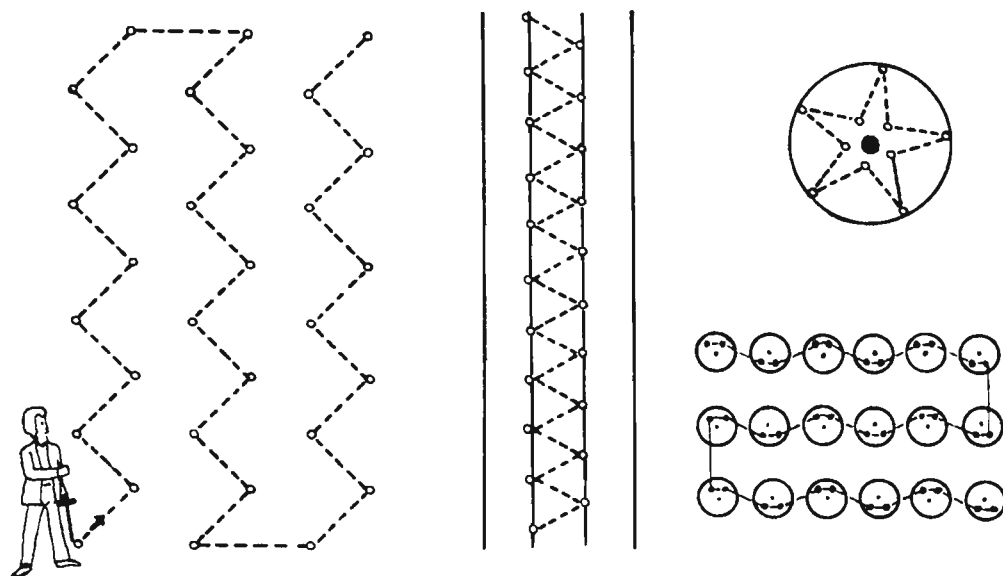

Figure 16. Soil sampling techniques used in diagnosing the presence of nematodes.

Methods for isolating nematodes from soil and plant tissue samples

In the case of *Heterodera* or *Meloidogyne*, the swollen females can be observed directly on the roots or in root galls. However, for the remaining genera, the nematodes must be extracted from the soil or the roots. The easiest and best known technique for extracting nematodes from soil is using a Baermann funnel (Figure 17 a). Ideally, the soil sample should be suspended in water and passed through a series of sieves. The nematodes and the residue can then be placed in a Baermann funnel (Figure 17 b) or extracted using the sugar flotation technique (Figure 17 c).

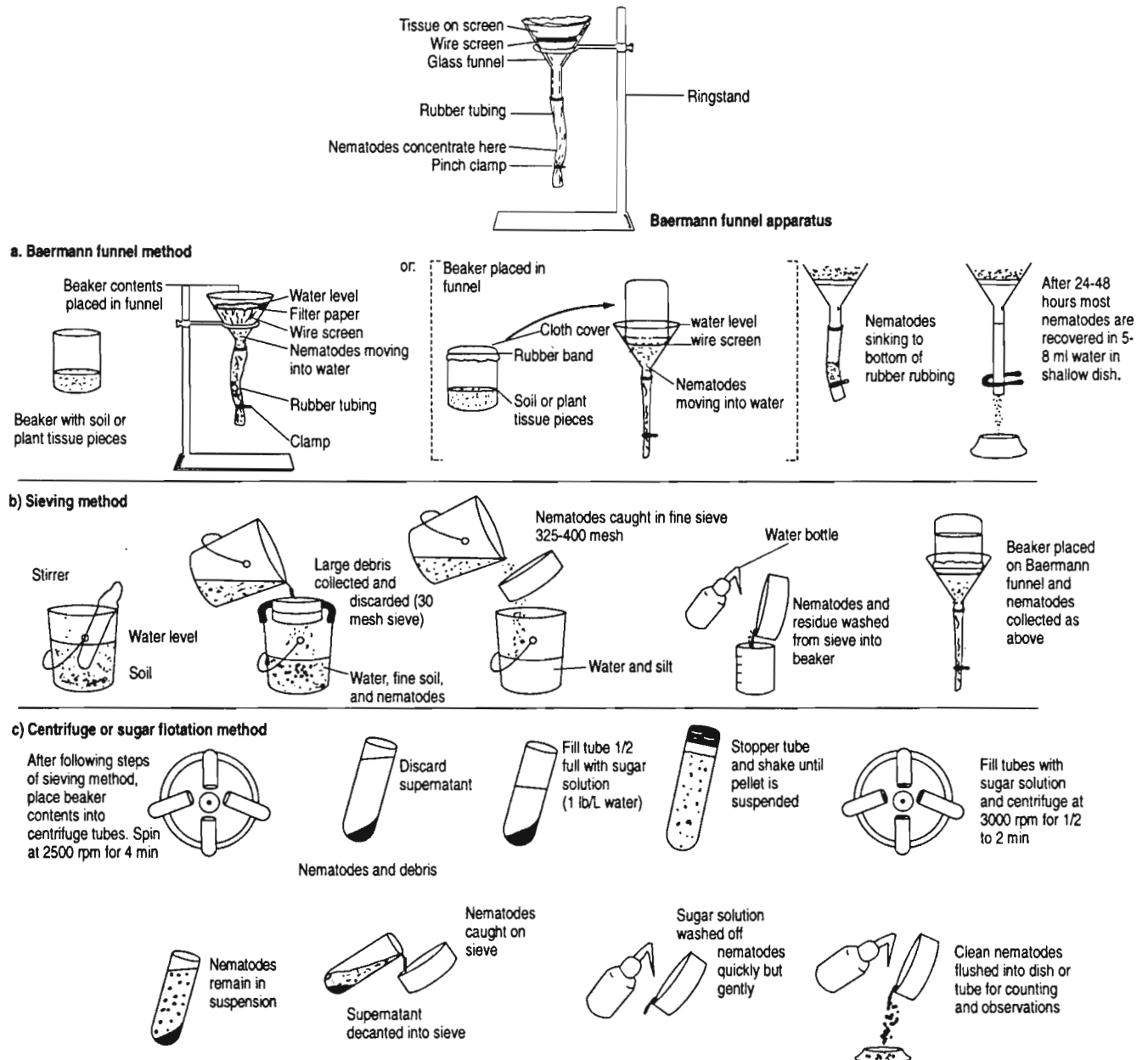

Figure 17 a, b, c. Methods for isolating nematodes from soil or plant tissue: Baermann funnel method and sugar flotation method.

From G.N. Agrios (1978), Plant Pathology, Academic Press, Inc., with permission.

Comparing two methods for isolating nematodes from soil and plant tissue

Set up two Baermann funnels, and compare the extraction efficiencies of a soil sample with sieving and one without sieving. When a nematode problem is detected and it is necessary to sample the area, use the techniques shown in Figure 17.

Identification of *Meloidogyne* species

The identification of *Meloidogyne* spp. requires using perineal sections. Figure 18 a, b, c and d shows the most important steps of this technique.

Preparing perineal patterns of *Meloidogyne* females

Perineal patterns are necessary for identifying species of some genera such as *Meloidogyne*. The procedure for doing this is described below.

Select galls containing mature females. Place in Petri dish with tap water. Single galls are preferable to compound galls. Tease the root tissue apart with forceps and half spear to remove adult females (Figure 18 a). Rupture the cuticle of the female near the neck and gently push the body tissues out (Figure 18 b).

Place the cuticle in a drop of 45% lactic acid on a plastic Petri dish. The lactic acid facilitates the removal of body tissues that adhere to the cuticle after trimming. Collect 10 to 20 cuticles in the drop and let them stand for 30 minutes to several hours. All cuts with the eye knife are done on the surface of a plastic Petri dish to minimize dulling (the knife should be kept very sharp).

Cut the cuticle in half crosswise with cataract knife. Remove the cuticle with the perineal pattern from the lactic acid. Place it next to the drop and trim the perineal pattern to a square (Figure 18 c). Place the trimmed perineal pattern back in the 45% lactic acid. Cut 5 to 10 perineal patterns per sample. Thoroughly clean debris from the perineal pattern with the help of a pulp canal file.

Transfer the perineal patterns to a drop of glycerin on a clean glass slide. Align the perineal patterns so that they are in a straight line with the anus turned downward. The interior surface of the cuticle must be placed against the glass. Press the perineal pattern gently against the glass with the pulp canal file. Gently place the coverslip on the glycerin drop. Excess glycerin can be absorbed by a piece of filter paper. If there is insufficient glycerin, a small drop can be placed on the edge of the coverslip. Seal the coverslip and label the slide (Figure 18 d).

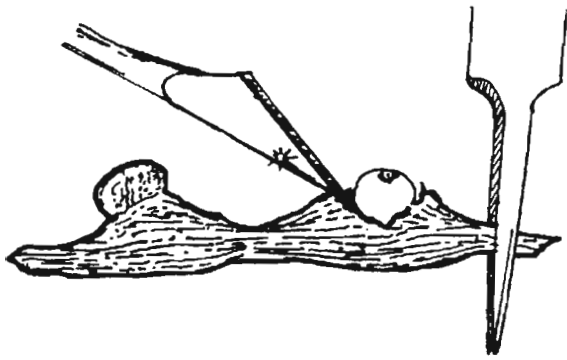

a. Female being removed from root fragment.

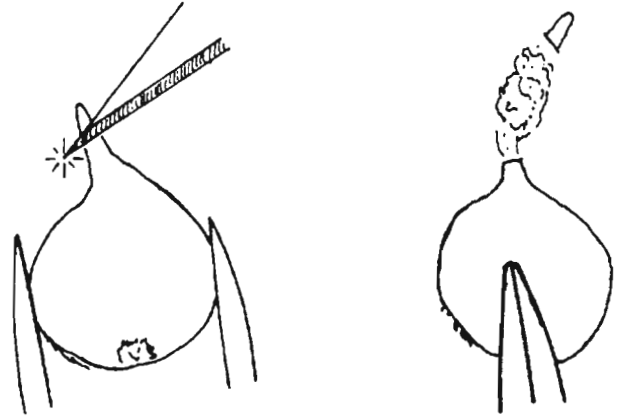

b. Excised female being ruptured and body tissue gently removed.

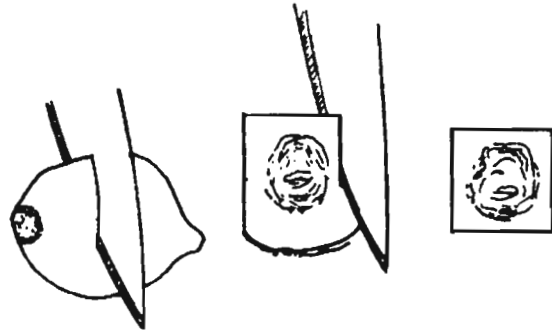

c. Cuticle being trimmed around the perineal pattern.

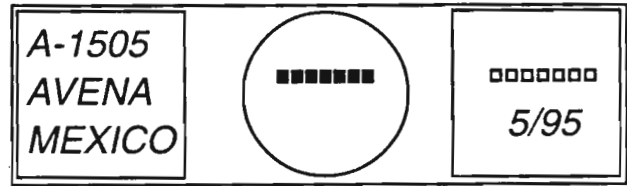

d. Completed slide.

Figure 18. Perineal patterns of *Meloidogyne* females.

Introduction

Bacterial species that are pathogenic to wheat can be classified into four groups: *Xanthomonas*, *Pseudomonas*, *Clavibacter* and *Erwinia*. The first two genera include species that cause economically important damages. Both genera are aerobic gram negative bacilli. *Xanthomonas* spp. do not reduce nitrate to nitrite and most of them produce an extracellular, mucoid, polysaccharide, yellow substance on media containing glucose or sucrose. Species of *Pseudomonas* are fluorescent (they produce fluorecein, a yellowish green pigment) on King B medium. The genus *Clavibacter* is the only one characterized by gram positive bacilli; *Erwinia* spp. are typically gram negative bacilli that are facultatively anaerobic.

Most plant pathogenic bacteria are rod shaped and measure 0.6-3.5 μm in length and 0.5-1.0 μm in diameter. The cell walls of most of these bacteria are surrounded by a dense, sticky substance. Most species have delicate flagella; some have a single flagellum, some have a tuft at one end of the cell and others have flagella distributed over all the cell surface.

When a bacterium multiplies on the surface of a solid agar medium, its progeny soon forms a visible mass called a colony. Bacteria reproduce at a surprisingly quick rate; under favorable conditions, they divide every 20 min. At that rate, a million bacteria can be generated over a 10-h period.

Identifying a bacterial disease

Bacterial diseases are often considered difficult to manage. In some cases, they are not easy to identify because they tend to be mistaken for physiological damage or damage caused by environmental stress. The methodology used for isolating and identifying bacterial diseases is very different from that used for identifying fungi; because of their size, bacteria cannot be identified under the microscope.

What follows is a description of the procedure used for identifying a bacterial disease taking *Xanthomonas* and *Pseudomonas* spp. as examples. In the first example, *Xanthomonas campestris* pv. *undulosa* is used.

Attach the sample to the diagnostic sheet and describe the observed symptoms. To confirm that the sample is infected by a bacterium, proceed as follows:

Observation using a dark field microscope. Using a scalpel cut a piece of leaf (about 3 x 3 mm) from the border between healthy and necrotic tissue. Prepare a slide with a drop of sterile water, add the sample and place the slide cover. Observe bacterial ooze coming out of the diseased tissue using a dark field microscope and low magnification (on the

dark field the ooze looks like a continuous flow of white dots coming out of the diseased tissue) (Figure 19).

Isolation. To isolate species of *Xanthomonas* and *Pseudomonas*, the most important genera, Wilbrink's and King B media are used. The ingredients and procedures for preparing these media are as follows:

Wilbrink's medium (selective medium for *Xanthomonas*)

Components:	
Bactopeptone	5 g
Sucrose	10 g
K ₂ HPO ₄	0.5 g
MgSO ₄ ·7H ₂ O	0.25 g
Na ₂ SO ₃ (anhydrous)	0.05 g
Agar	15 g
Distilled water	1000 ml

Sterilize the medium; let cool to 45-46°C and add 75 mg cycloheximide dissolved in 2 ml ethanol (75%).

King B medium (for fluorescent *Pseudomonas*)

Components:	
Agar	15 g
Proteose peptone No. 3 (DIFCO) or polypeptone	20 g
Glycerol	10 g or 15 ml
K ₂ HPO ₄ (anhydrous)	1.5 g
MgSO ₄ ·7H ₂ O	1.5 g
Distilled water	1000 ml
pH	7.2

Use a plate with Wilbrink's agar medium. From the border of the lesion take a piece of diseased leaf tissue of the same size as used for observation under the microscope. Shred it in sterile water using sterile scalpel and forceps. Soak for about 10 min. Using a sterile nickel or chrome wire loop (if a wire loop is not available, see instructions for making one in Figure 20 a), gently rub the agar in four dilution fields flaming the loop and cooling it after each field as indicated in Figure 20 b and c.

Incubate at 27-30°C for three days. Then observe the typical yellow mucoid colony suspected to be *X. campestris* pv. *undulosa*. Sub-culture by dilution streaking to obtain a pure culture (Figure 20 b). A pure colony is produced by multiplying a single cell separated from the others through dilution streaking.

Pathogenicity test

This test is most important to determine whether the pure culture obtained is from a pathogenic bacterium. Use young host plants of the crop where you observed the lesion—wheat, in this case. Using a syringe, inject a concentrated bacterial suspension prepared from a pure culture of the suspected bacteria into the stem of wheat plants. Figure 21 a and b shows how to position the needle correctly to infiltrate the suspension into the leaf blade.

Incubate plants for one week in a moist chamber (Figure 22). If extended lesions similar to symptoms observed in the field are reproduced, the isolate is most probably pathogenic. However, to verify Koch's postulates it is necessary to re-isolate the same bacteria that was inoculated. Using the same agar medium, the appearance of the re-isolated colony has to be the same as that of the colony initially isolated and obtained in pure culture from the field sample.

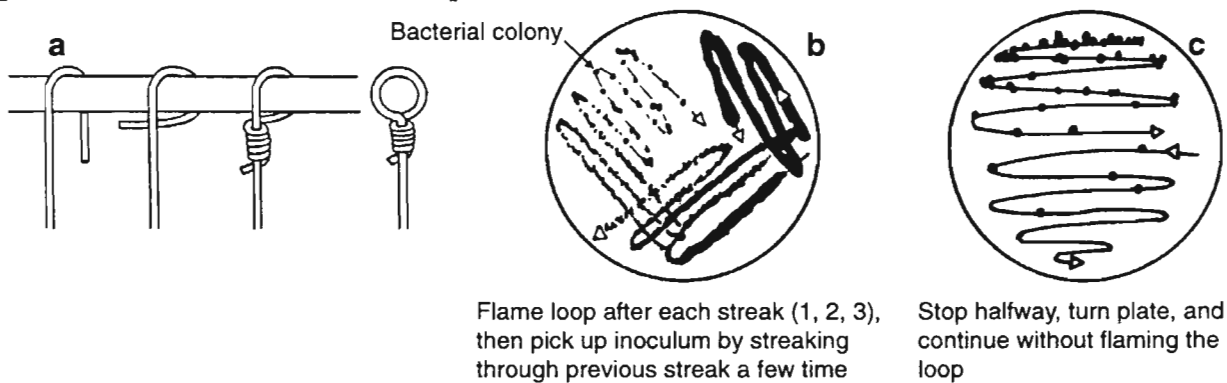

Figure 20. How to make a bacterial culture. a. Preparation of wire inoculating loop using 24 swg nichrome or platinum wire and a 4-mm diameter glass rod. b. Preparation of concentrated inoculum. c. Preparation of dilute suspensions.

Source: Lelliott, R.A., and Stead, D.E. 1987. Methods for the diagnosis of bacterial diseases of plants.

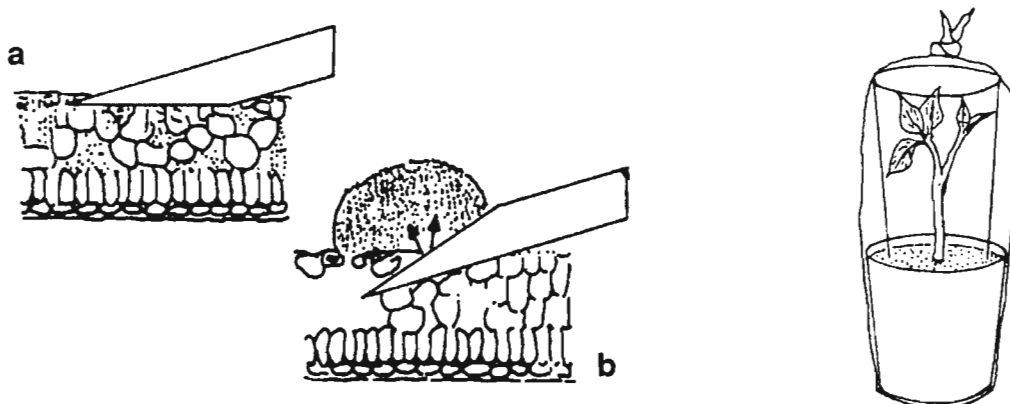

Figure 21. Correct (a) and incorrect (b) way of holding the hypodermic needle during infiltration of a leaf.

Source: Kiraly et al. 1970. Methods in plant pathology. Budapest. p. 161.

Figure 22. Host seedling incubated in a polyethylene sleeve with a wire frame to keep the plant from touching the polyethylene.

Source: Kiraly et al. 1970. Methods in plant pathology. Budapest. p. 158.

Biochemical and physiological tests

After the pathogenicity test, you need to perform different biochemical and physiological tests to determine which genus or species the isolated pathogen belongs to. We will perform three basic tests as examples.

Fluorescence on King B medium. Take a single colony from each of the two types of bacteria that you were given and streak them onto two different plates of King B medium, as previously described. Observe the fluorescence after 4 days' incubation at 27°C. This allows the identification of *Pseudomonas* spp. (Figure 23).

Nitrate reduction test. Use this test to distinguish important groups of bacteria, such as *Xanthomonas* spp., that are not able to reduce nitrates. The medium used is described below:

Medium for the nitrate reduction test

Components:

Peptone	10 g
K ₂ HPO ₄	5 g
Yeast extract	1 g
KNO ₃	1 g
Agar	2 g
Distilled water	1000 ml

For this test, use sterile test tubes containing 5 ml medium. With a wire loop, inoculate the medium with fresh, pure culture placing it at the bottom of the tube. Incubate tubes for two days or more until adequate development is observed. Then add the following:

Lugol	One drop
Reagent I (Greiss I)	0.5 ml
Reagent II (Greiss II)	0.5 ml

Reagent I (Greiss I): 0.8% sulphanilic acid in 5N acetic acid (the latter is prepared by mixing 57 ml glacial acetic acid and 143 ml distilled water).

Reagent II (Greiss II): N-(1-naphthyl) bichlorhydrate 0.1% aqueous ethylendiamine.

If nitrite is present, a red spot will appear on the surface in a few minutes, and the test is positive. If no nitrite is detected, add a small amount of zinc dust with the tip of a spatula. If a red spot appears after a few minutes, this indicates nitrate is present in the medium and confirms the test is negative (Figure 24).

KOH test. Use the same plates as for the first test. Place a few drops of 3% KOH solution on a glass slide. With a needle, take some culture and quickly swirl it through the medium. If the strain is gram negative, the suspension thickens and forms a mucoid thread when the needle is lifted. Gram positive bacteria disperse in the drop and do not cause this reaction (Figure 25).

Indicate whether your bacteria are gram positive or negative. Except for *Corynebacterium* spp., most plant pathogenic bacteria show a negative reaction.

E. Duveiller



Figure 19. Procedure for making a preliminary diagnosis of a bacterial disease.

E. Duveiller

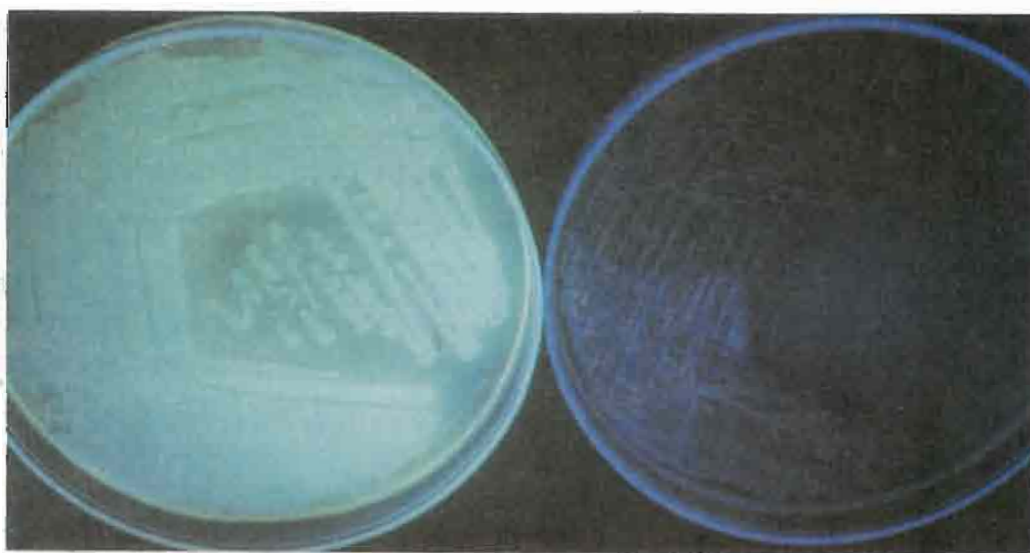

Figure 23. *Pseudomonas* sp. fluorescing on King B medium.

E. Duveiller



Figure 24. Nitrate to nitrite reduction test.

E. Duveiller



Figure 25. Detecting gram negative bacteria using the KOH test.

Introduction

Viruses that infect plants never leave their hosts, because they cannot survive outside them. For this reason, viruses are not disseminated by wind or water, as is the case for most fungi and bacteria. Transmission of viruses from plant to plant can take place through vegetative propagation or mechanically by sap, pollen, insects, mites, nematodes, dodder, and fungi. Plant pathogenic viruses differ from other pathogens in their size and shape, their simple chemical makeup (nucleic acid and protein) and physical structure, method of infection, propagation, translocation within the host, dissemination and symptoms.

Because of their small size (measured in nanometers) and transparency, viruses cannot always be observed or detected with the methods used on other pathogens. Methods for detecting viruses on plants are based mainly on virus transmission from diseased plants to healthy ones by means of sap, parasites or insect vectors. However, definite proof that a virus is present is only possible by purifying it, observing it under an electron microscope and/or doing serological and nucleic acid testing.

Barley yellow dwarf (BYD) and barley stripe mosaic (BSM) are some of the most important cereal virus diseases.

Transmission of specific variants of barley yellow dwarf virus (BYDV) by the most important species of cereal aphids.

Aphid species	MAV	PAV	BYDV variants		
			RMV	RPV	SGV
<i>M. dirhodum</i>	+	+	-	-	-
<i>R. maidis</i>	-	-	+	-	-
<i>R. padi</i>	-	+	-	+	-
<i>R. rufiabdominalis</i>	-	+	+	+	-
<i>S. graminum</i>	-	+	-	+	+
<i>S. avenae</i>	+	+	-	-	-

(+) Indicates aphid species reported to consistently transmit BYDV variants in trials using a single aphid. Transmission efficiency varies depending on the virus-vector combination.

Source: Gildow, F.E. 1987. Barley yellow dwarf virus: Aphid vector interactions associated with virus transmission and vector specificity. In: P.A. Burnett, ed. World Perspectives on Barley Yellow Dwarf. Proceedings of the International Workshop. Udine, Italy, pp. 111-122.

Barley yellow dwarf virus

This virus is transmitted by aphids acting as vectors. Five aphid species have been found to be the most important vectors: *Rhopalosiphum padi*, *R. maidis*, *Sitobion avenae*, *Schizaphis graminum* and *Metopolophium dirhodum*. Usually called cereal aphids, they transmit different variants of BYDV (see table).

Identification of BYDV aphid vectors

Observe the different aphids species under the stereoscope, differentiating them by particular features such as: shape and size of the cornicles, antennae length, wing vein location and color.

BYDV transmission

BYDV transmission using aphids can be achieved following two methods, one for the field and one for the greenhouse:

1. Aphids are collected from fields where BYD symptoms are present, and are placed in Petri plates (seal them to avoid escapes). If they are identified as cereal aphids, then they are allowed to feed on healthy indicator plants that have been grown protected (with cylinders, cans, boxes, etc.), to be sure that they have not been infested by other insects. Place aphids on leaves or stems and cover them again (Figure 26 a, b, c). Using susceptible varieties such as Bow 'S', Black Hull-less and Atlas 66 for inoculation is recommended. Plants are examined for symptoms a month after inoculation.

Incubate plants in the greenhouse at 20-25°C. After 72 h take out the aphids and fumigate the plants. If the ELISA test is available, leaf samples should be taken and analyzed eight days after inoculation to determine whether transmission was successful and what variant was transmitted. If ELISA is not available, plants will show symptoms of the disease 10-12 days later. In the latter case, the variant present can only be approximated based on the specificity of the vector species/virus variant transmission.

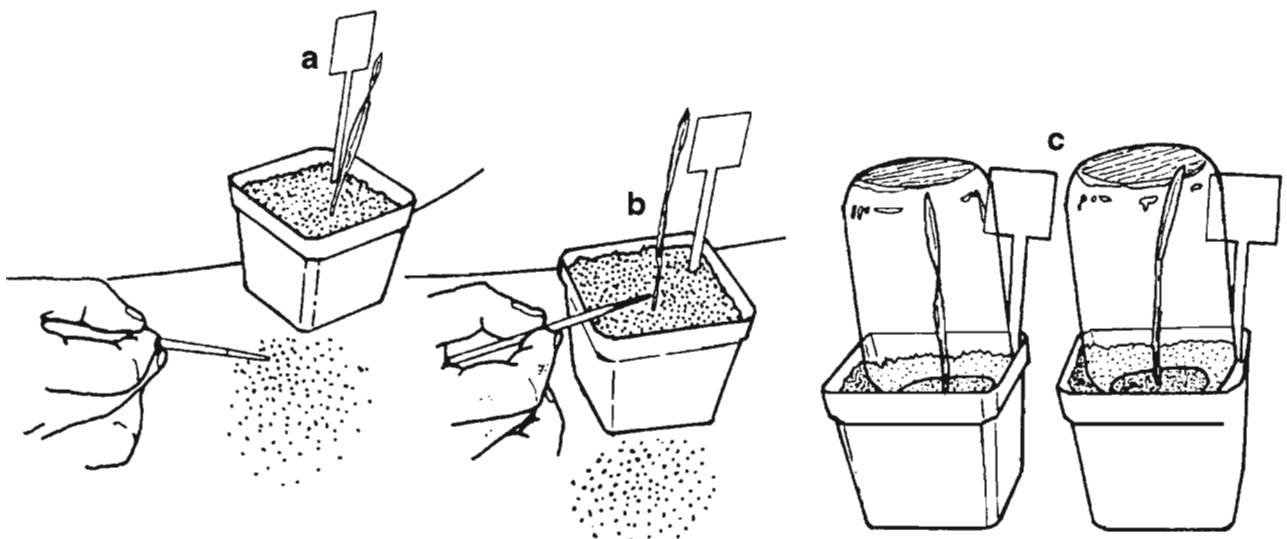

Figure 26 a, b, c. Steps to follow when inoculating plants using vector aphids.

2. This method is useful when a greenhouse and healthy aphids are available. Aphids are placed in Petri plates with plant material infected with the virus on moist filter paper or the leaf pieces are buried in moist sand to maintain a favorable environment. Seal the plate with parafilm and place in darkness for 36-48 h. It can be assumed that during this period the aphid has fed on the infected tissue and has acquired the virus. Then, take the aphid out and transfer it to another plate with healthy plant tissue so it will infect the tissue. In both cases plants of highly susceptible varieties such as Black Hull-less should be used. Plants should be kept at 20°C under bright light; otherwise, symptoms will not express as they should.

Barley stripe mosaic virus

This is one of a few viruses transmitted on the seed of grass species. When barley stripe mosaic (BSM) attacks barley, it can be mistaken for *Pyrenophora graminea*, since early symptoms of both diseases are similar.

The BSM virus has been observed on barley in most countries around the world; its distribution is so broad that it may have been disseminated through international seed shipments. It has also been found on wheat and oats.

BSMV transmission

This disease is seedborne or mechanically transmitted through sap. Mechanical transmission is one of the most used diagnostic tests, since it is efficient, sensitive, cheap, and provides essential information for the characterization of the virus.

Viruses can be transmitted among plants of the same species or genus or even of different genera. In fact, each virus can produce characteristic symptoms on a range of plants sometimes belonging to a genus different from the natural host. These plants are very important for diagnosis of a viral disease and are called "indicator plants". Among the dicotyledons that have been artificially infected for use as indicator plants are *Chenopodium amaranticolor*, *Ch. album*, *Ch. quinoa*, *Beta vulgaris*, *Spinacea oleracea* and *Nicotiana tabacum* var. *Samsun*.

This type of transmission has the disadvantage that it takes several weeks before the reaction is expressed. Even then, the virus must be successfully extracted from plant tissue. During inoculation, be sure to injure plants slightly so the virus can penetrate.

Procedure: Wash hands with soap and water. Select indicator plants and the leaves to be inoculated. Crush infected material in a sterile mortar with 0.5-1.0 ml distilled water. Add carborundum (half the volume of a chickpea). With a moist finger or a cotton swab rub the sap suspension on each marked leaf, moving from the petiole to the leaf tip,

supporting the leaf with the other hand. Do not rub the same area twice. Repeat with each marked leaf. Immediately after inoculation, wash the inoculum from the test plant using distilled water with an atomizer. Infection is immediate; leaves are washed to eliminate compounds produced by the plant to inhibit infection. Incubate plants in the greenhouse and check them every day because it is important to know the day symptoms appear.

Detecting seed transmission of the virus

To detect the virus on infected seeds, sow seeds in the greenhouse. Incubate under good light and temperature (around 25°C) conditions so symptoms will express without environmental stress. Symptoms start to appear when plants are at the 2-3 leaf stage or later, depending on the original virus concentration on the seed. If concentration was low, plants will take longer to express symptoms.

Appendix

Culture media used for isolation, increase and conservation of cereal pathogens.

Pathogen	Isolation	Increase	Conservation
<i>Fusarium</i> spp.	PCNB (soil) Corn meal agar PDA	Chinese bean medium PDA Pieces of sterile maize stems	Sterile wheat grain Sterile soil
<i>Helminthosporium sativum</i>	PDA Czapek's modified broth (specific)	PDA Czapek's modified broth (specific) Czapek's broth	Sterile wheat grain Infected leaves
<i>H. spiciferum</i>	PDA	PDA	Sterile wheat grain
<i>H. tritici repentis</i>	V-8 (30%)	V-8 (30%)	Infected leaves
<i>H. teres</i> f. <i>teres</i> <i>H. teres</i> f. <i>maculata</i>	V-8 (15%)	V-8 (15%)	Infected leaves
<i>Pythium</i> spp.	Use traps (wheat seedlings) sown in sterile sand with infected tissue	Corn meal agar	Wheat leaves in sterile water
<i>Ophiobolus graminis</i> syn. <i>Gaeumannomyces graminis</i>	Use traps (wheat seedlings) sown in sterile sand with infected tissue	Corn meal agar	Sterile oat grain
<i>Rhizoctonia</i> spp.	Use traps (wheat seedlings) sown in sterile sand with infected tissue	PDA	PDA
<i>Sclerotium rolfsii</i>	PDA	PDA	PDA
<i>Septoria tritici</i>	PDA 444 yeast-peptone	Liquid medium yeast-peptone 444 yeast-peptone medium	4-44 medium Leaf medium
<i>Septoria nodorum</i>	PDA	Medium for <i>Septoria nodorum</i>	Medium for <i>S. nodorum</i>
<i>Rhynchosporium secalis</i>	Lima bean agar	Lima bean agar	Lima bean agar
<i>Alternaria</i> spp.	PDA	PDA	PDA

ISBN: 968-6923-82-9

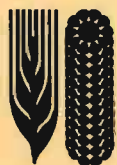

International Maize and Wheat Improvement Center
Centro Internacional de Mejoramiento de Maíz y Trigo
Lisboa 27, Apartado Postal 6-641, 06600 México, D.F., México