

سلام میں پہل کرنے کی فضیلت

”اور حضرت ابو امامہؓ کہتے ہیں کہ رسول کریم ﷺ نے فرمایا لوگو! تم میں سے اللہ کے نزدیک تر وہ شخص ہے جو سلام کرنے میں پہل کرے۔“ (احمد)

ترمذی و ابوداؤد

Biomechanics of Peripheral Nerve and spinal nerve roots



DR.AYESHA BASHARAT
BSPT, PP-DPT, M.PHIL*

Nervous System

control center and
communications network

⌘ Three broad roles:

- It senses changes in the body and in the external environment
- It interprets these changes
- Responds to this interpretation by initiating action in the form of muscle contraction or gland secretion



Division of Nervous System

- ⌘ Central nervous system:???
- ⌘ Peripheral nervous system
- ⌘ 12 pairs of cranial nerves
- ⌘ 31 pairs of Spinal nerves
- ⌘ Posterior (dorsal) root and an Anterior root, which unite to form the spinal nerve in intervertebral foramen

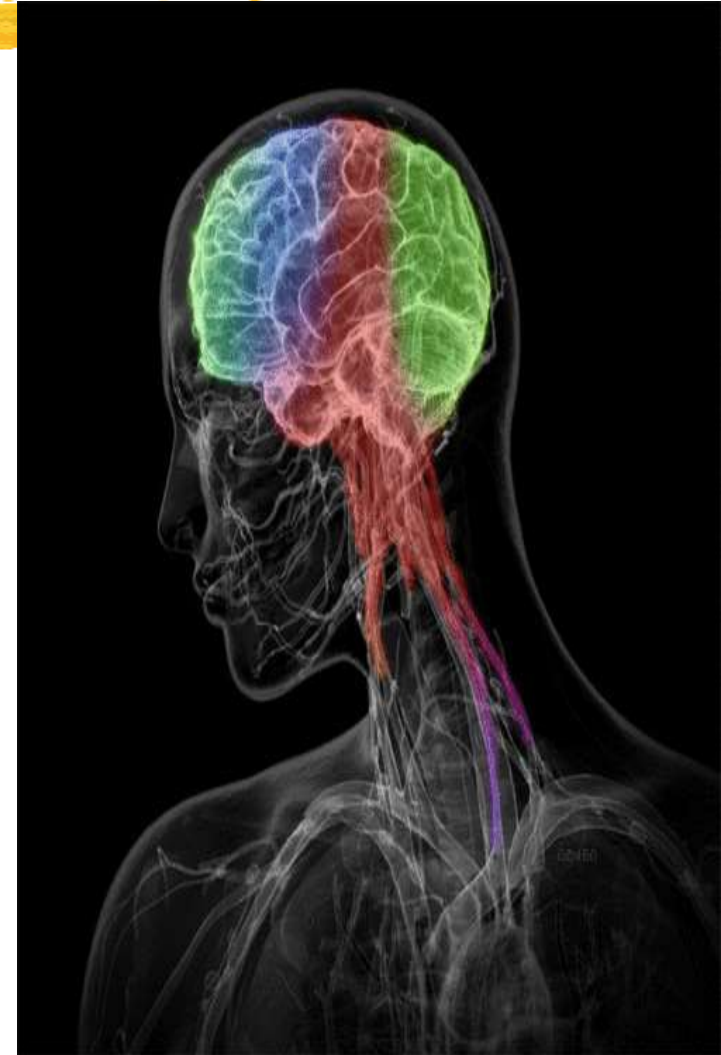



⌘ After exit from foramine:

⌘ Dorsal rami, which innervate the muscle and skin of the head, neck, and back.

⌘ Generally larger and more important Ventral rami, innervate the ventral and lateral parts of structures as well as the upper and lower extremities

Spinal Nerves

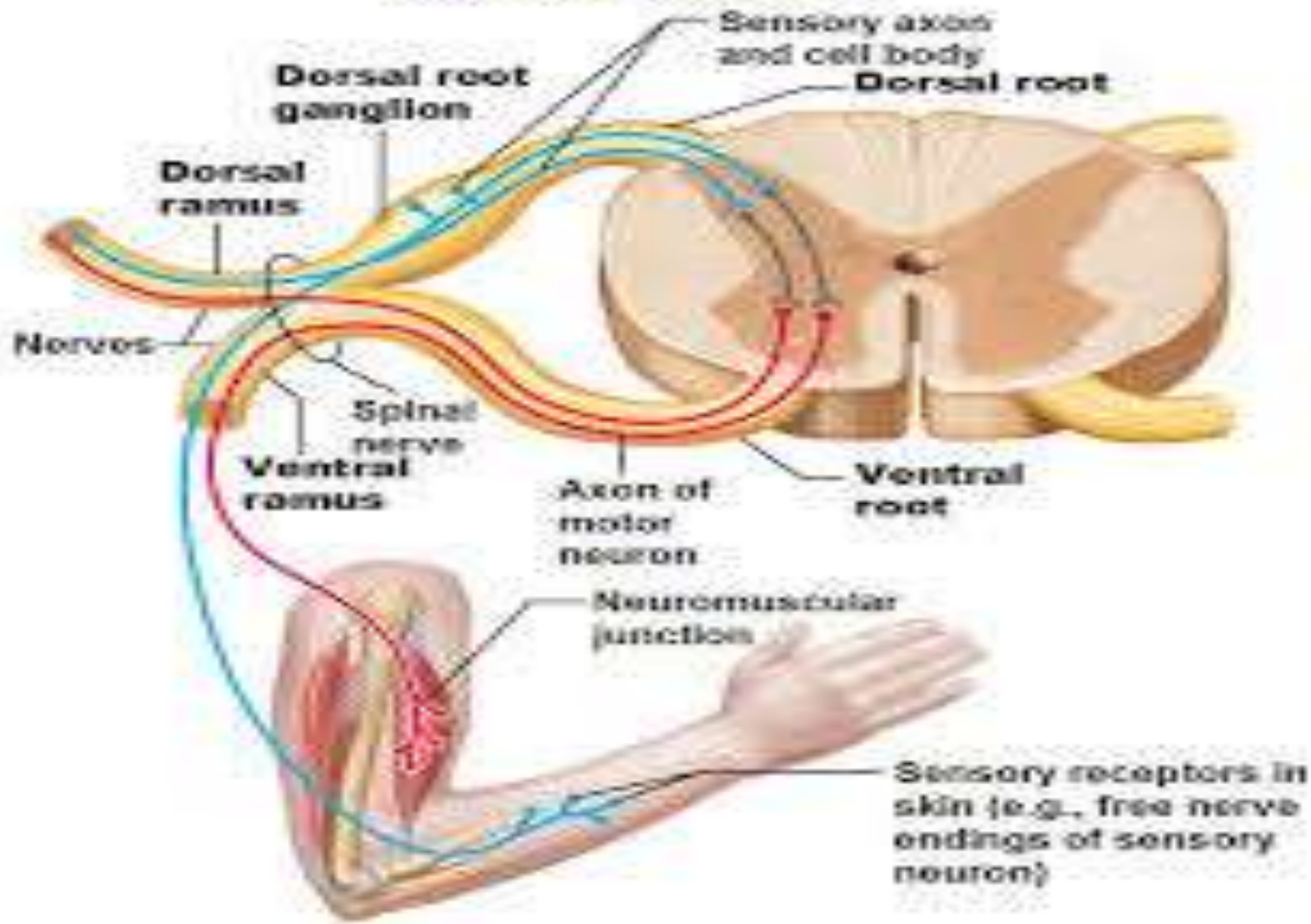

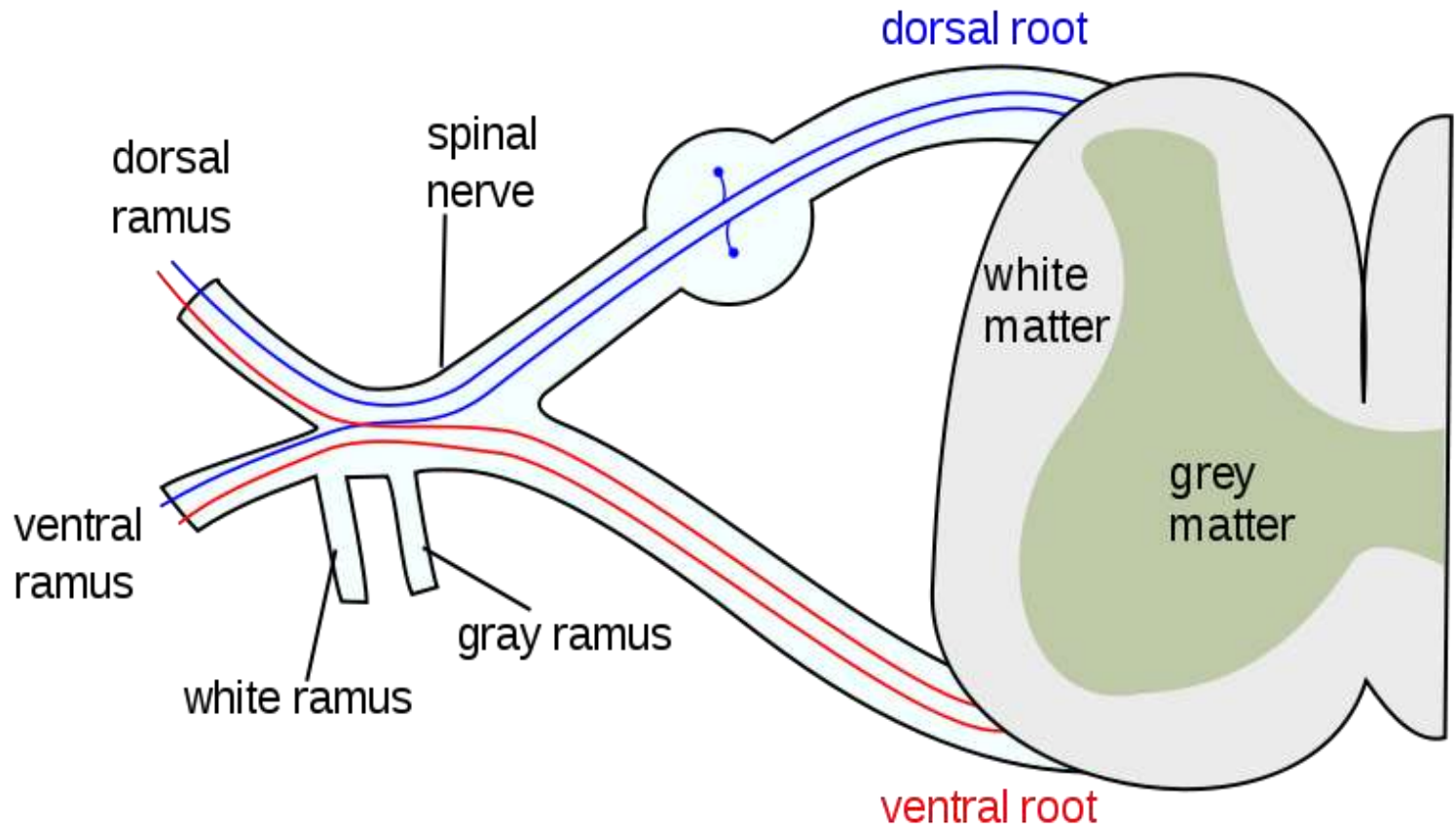

Anatomy and Physiology of Peripheral Nerves

- ⌘ The peripheral nerves are complex structures consisting of nerve fibers, connective tissue and blood vessels.
- ⌘ Each component responds differently to injuries and traumas

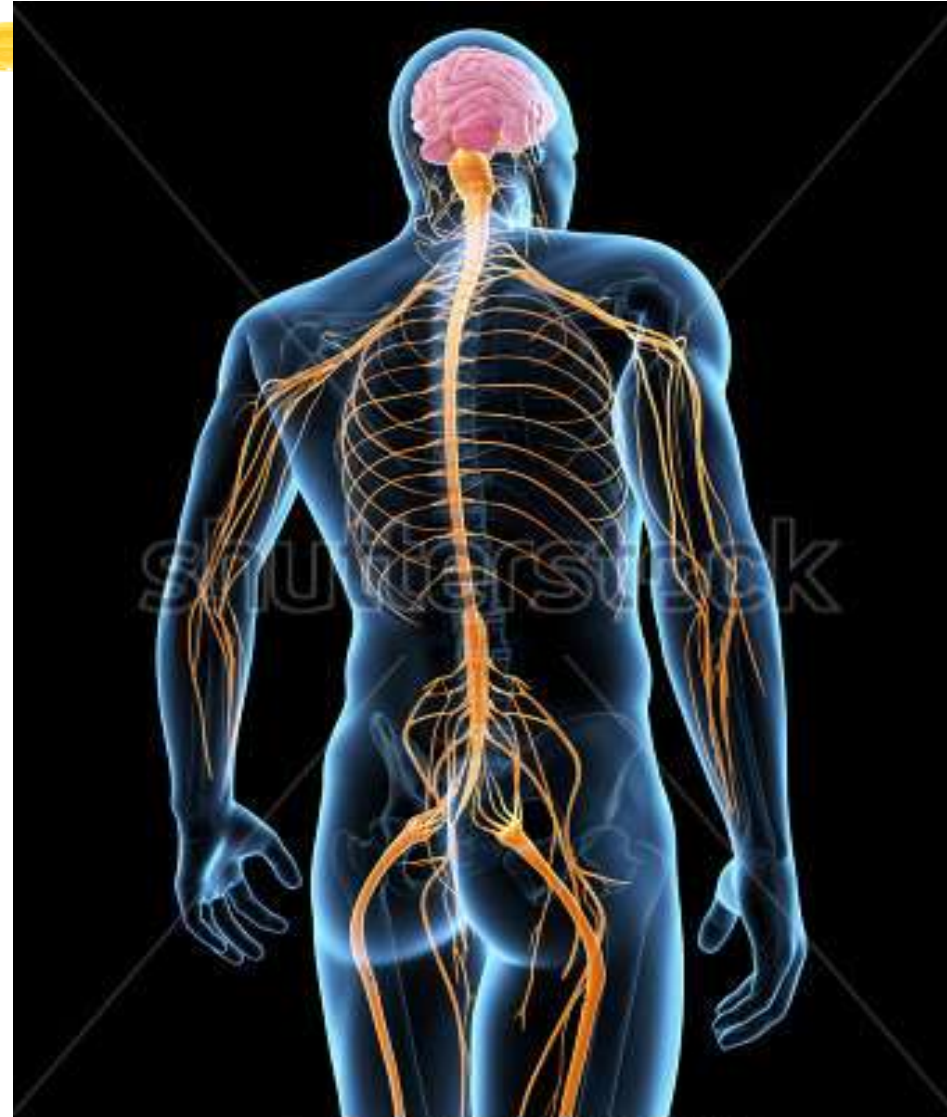

⌘ Sensory neurons

⌘ Motor neurons

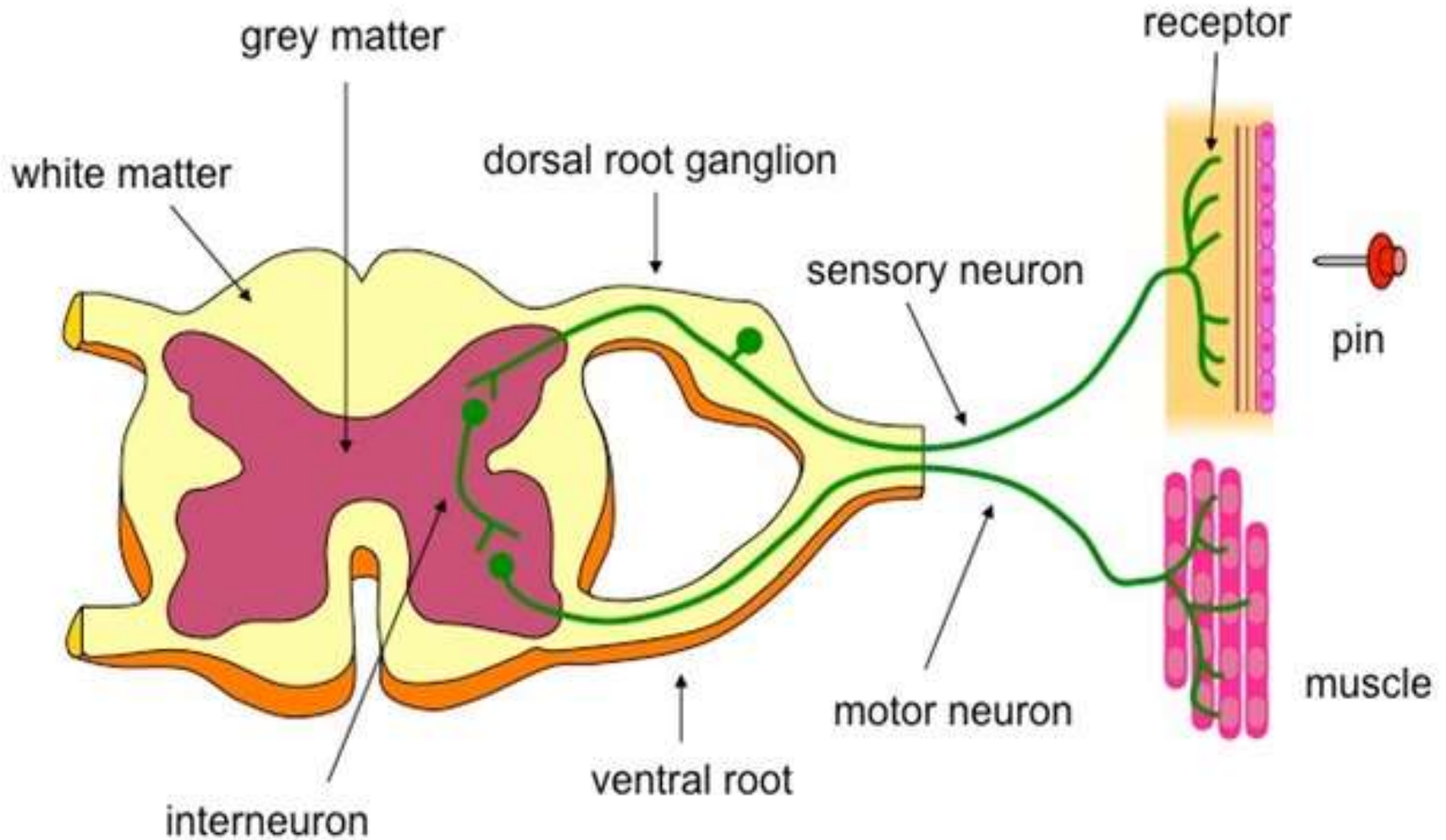

Nerve fiber

- ⌘ The term nerve fiber refers to the elongated process (axon) extending from the nerve cell body along with its myelin sheath and Schwann cells
- ⌘ **Axonal transport systems**
- ⌘ Most axons of the peripheral nervous system are surrounded by multilayered, segmented coverings known as myelin sheaths
- ⌘ Schwann cells
- ⌘ Unmyelinated gaps called nodes of Ranvier

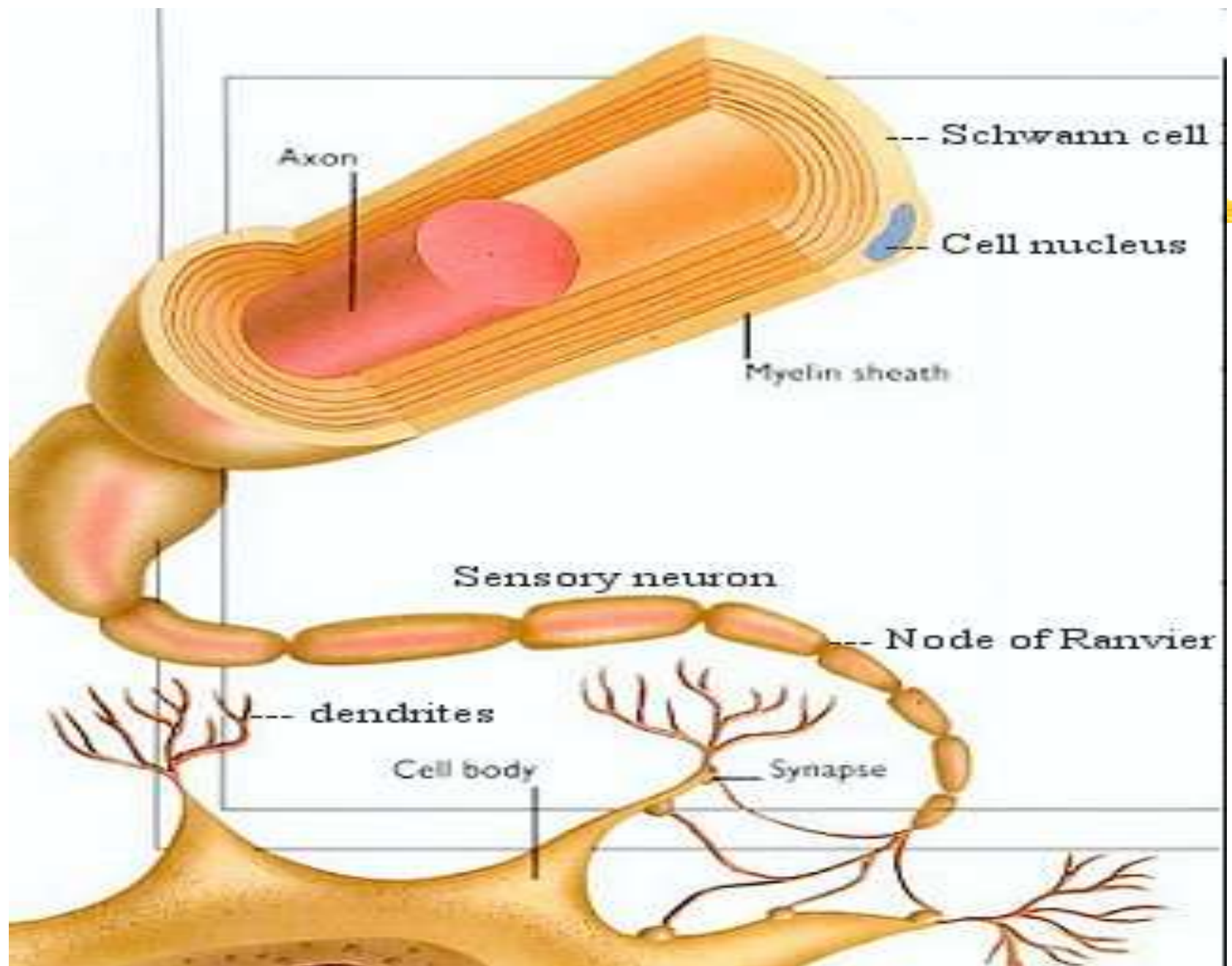

⌘ **Saltatory conduction**

⌘ The conduction velocity of a myelinated nerve is

directly proportional to the diameter of the fiber,
which usually ranges from 2 to 20 μm

⌘ Larger motor fibers for skeletal muscles and large sensory fibers carrying touch heat cold senses etc....

⌘ Smallest fibers for dull pain fibers

⌘ Nerve fibers are packed closely in fascicles which are further arranged into bundles that make up the nerve itself

⌘ The fascicles are the functional subunits of the nerve.

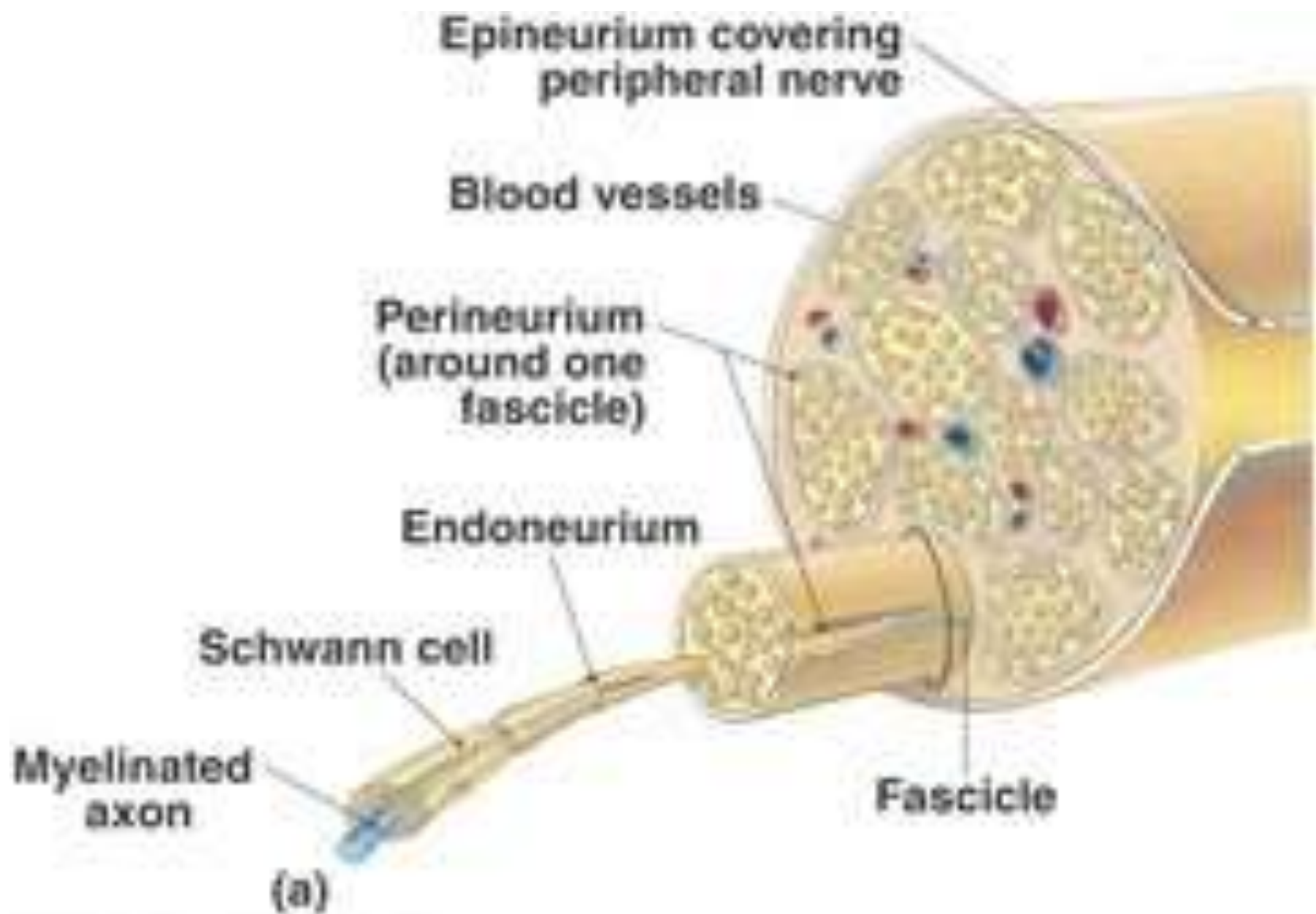

Saltatory conduction (from the Latin saltare, to hop or leap) is the propagation of action potentials along myelinated axons from one node of Ranvier to the next node, increasing the conduction velocity of action potentials

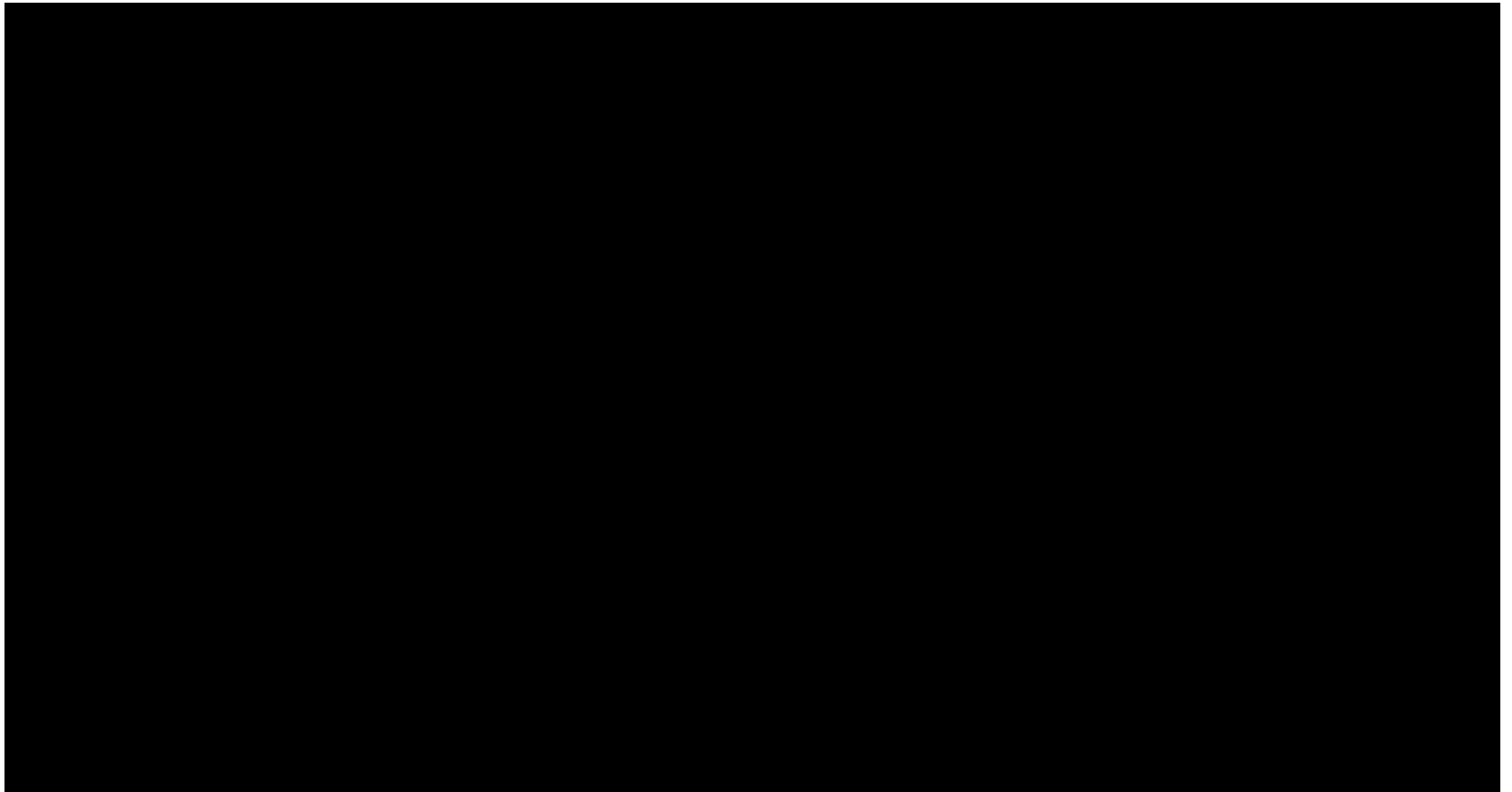





Intraneural Connective Tissue Of Peripheral Nerves

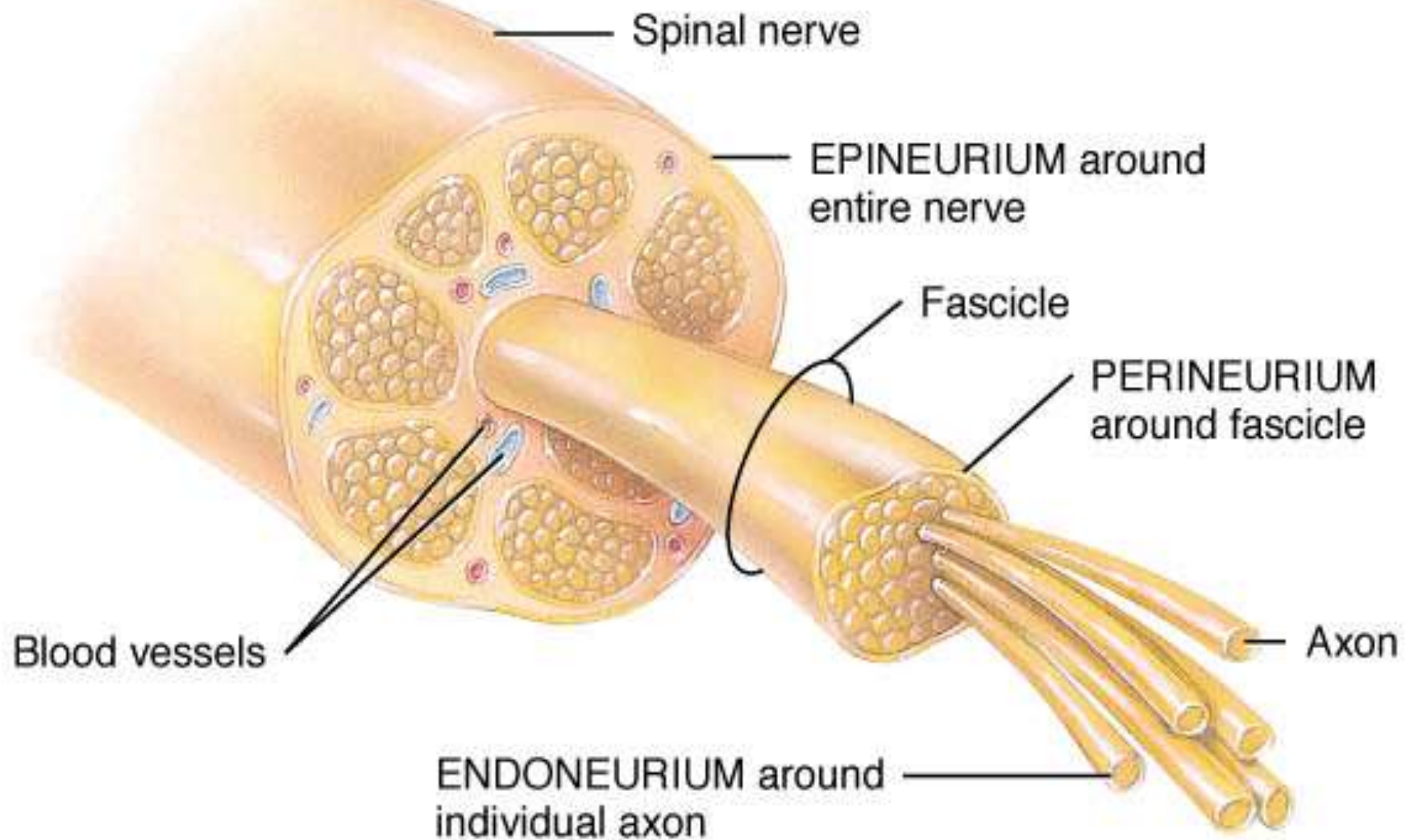

- ⌘ Successive layers of connective tissue surround the nerve fibers-called the endoneurium, perineurium , Epineurium to protect the fibers continuity
- ⌘ Nerves are extremely susceptible to stretching and compression.

- ⌘ The outer most layer, the Epineurium, is located superficially in the nerve.
- ⌘ This loose connective tissue layer acts as a cushion during movements of the nerve, protecting from external trauma and maintaining the oxygen supply system via the epineural blood vessels.



- 
- ⌘ The amount of epineural connective tissue varies among nerves and at different levels within the same nerve.
 - ⌘ Where the nerves lie close to bone or pass joints, the epineurium is often more abundant than elsewhere, as the need for protection may be greater in these locations.
 - ⌘ The **Perineurium** is a lamellar sheath that encloses each fascicle

⌘ The spinal nerve roots are devoid of both epineurium and perineurium, and the nerve fibers in the nerve root may therefore be more susceptible to trauma

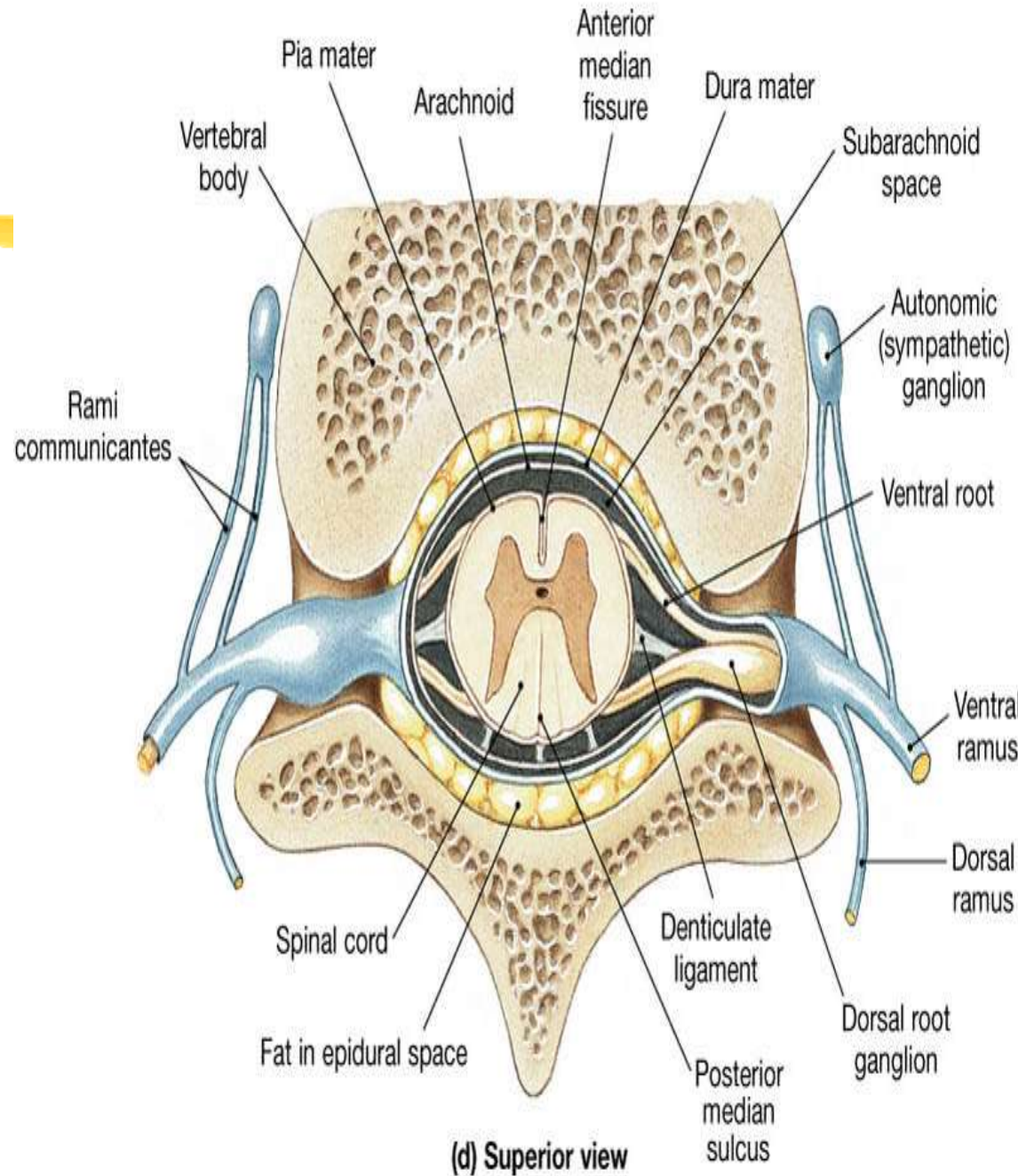



⌘ **Perineurium:** sheath has great mechanical strength as well as a specific **Biochemical Barrier**.

⌘ **Strength demonstrated:** fascicles can be inflated by fluid to a pressure of approximately 1000 mm of mercury (Hg) before the perineurium ruptures.

⌘ **Biomechanical barrier function or the perineurium**:: chemically isolates the nerve fibers from their surroundings, thus preserving an ionic environment of the interior of the fascicles

⌘ **The endoneurium**, the connective tissue inside the fascicles, is composed principally of fibroblasts and collagen.

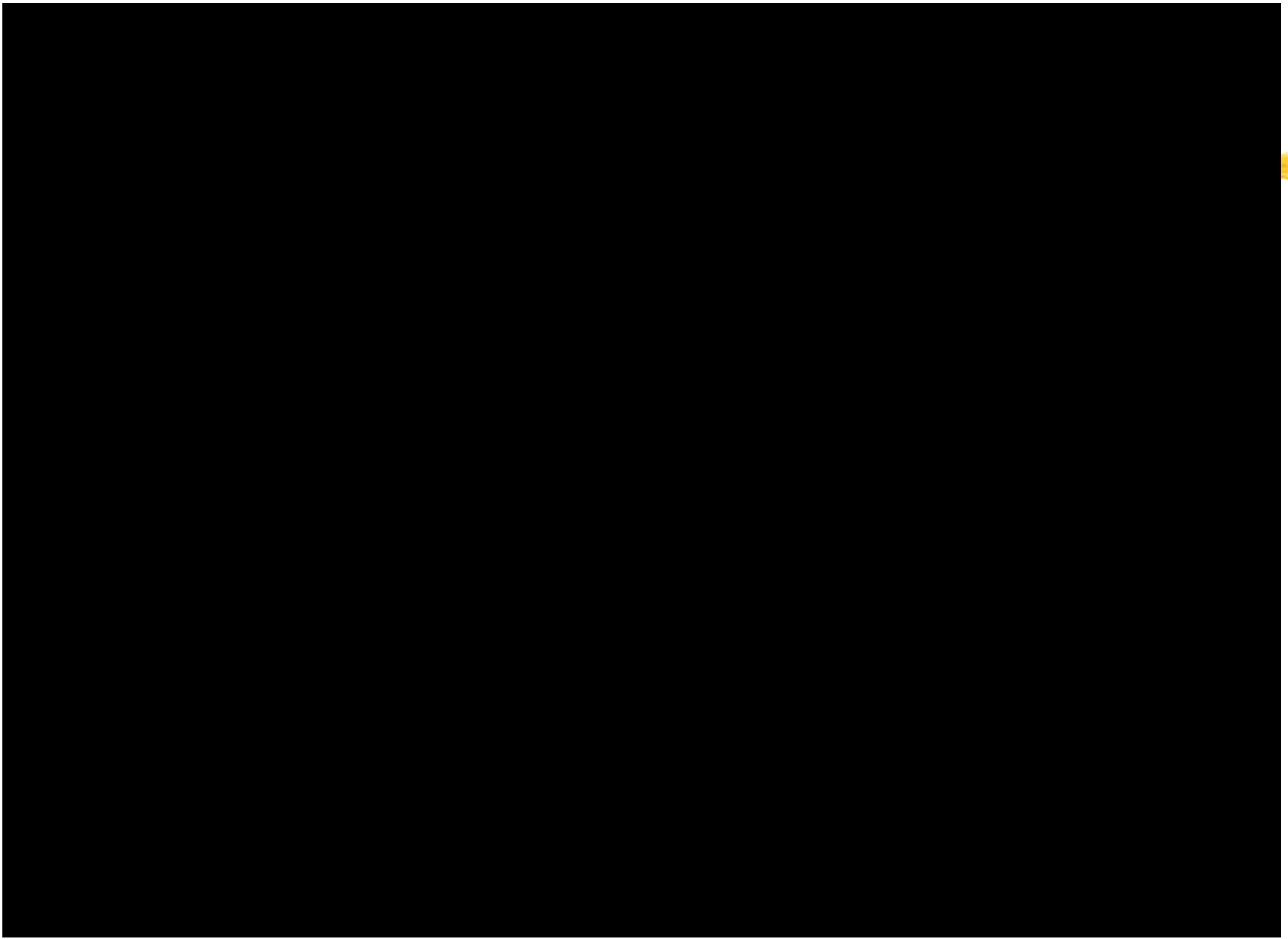



THANK YOU

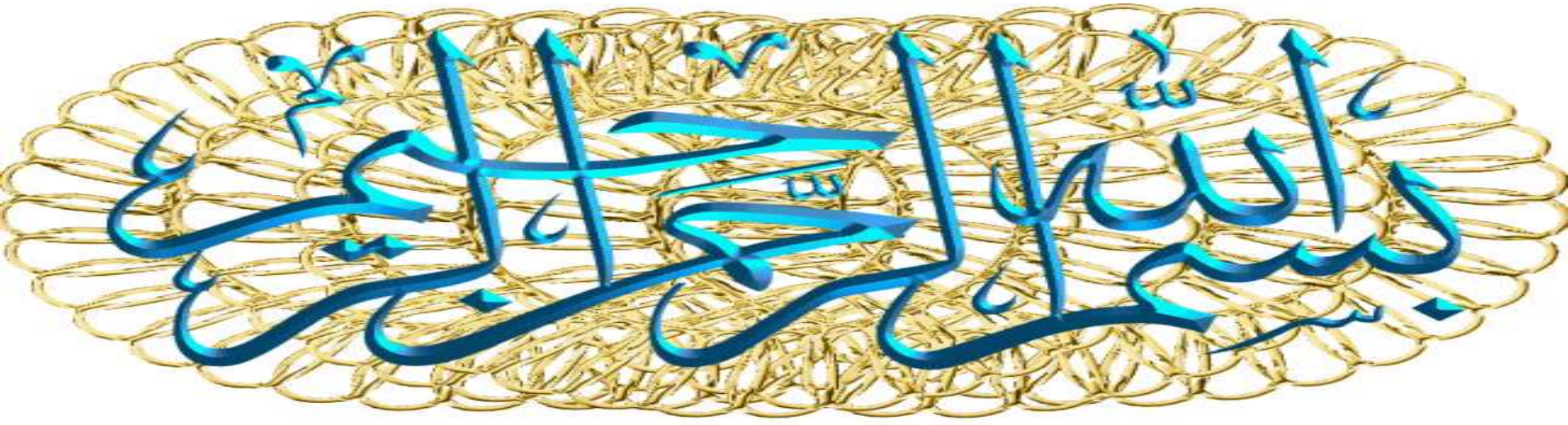

بِسْمِ اللّٰهِ الرَّحْمٰنِ الرَّحِیْمِ
مجلس میں بیٹھنے کے آداب

حضور ﷺ نے فرمایا

کوئی شخص خود بیٹھنے کے لئے دوسرے کو اس کی جگہ سے کھڑا نہ کرے
اس کی بجائے مجلس میں ایک دوسرے کو جگہ دو، اور دوسروں کے لئے

The Microvascular System Of Peripheral Nerves

- ⌘ The peripheral nerve is a well-vascularized structure containing **vascular networks** in the epineurium, the perineurium, and the endoneurium
- ⌘ The blood supply to the peripheral nerve as a whole is provided by large vessels that approach the nerve **segmentally** along its course.

⌘ Large vessels run longitudinally and frequently ***anastomose*** with the vessels in the perineurium and endoneurium **constitute longitudinal vascular system.**

⌘ When these local nutrient vessels reach the nerve, they divide into ***ascending and descending*** branches.



⌘ **Oblique course** through the perineurium vessels follow oblique course

Note:

⌘ It is extremely difficult to induce complete **ischemia** to a nerve by local surgical procedures.
(microvascular)

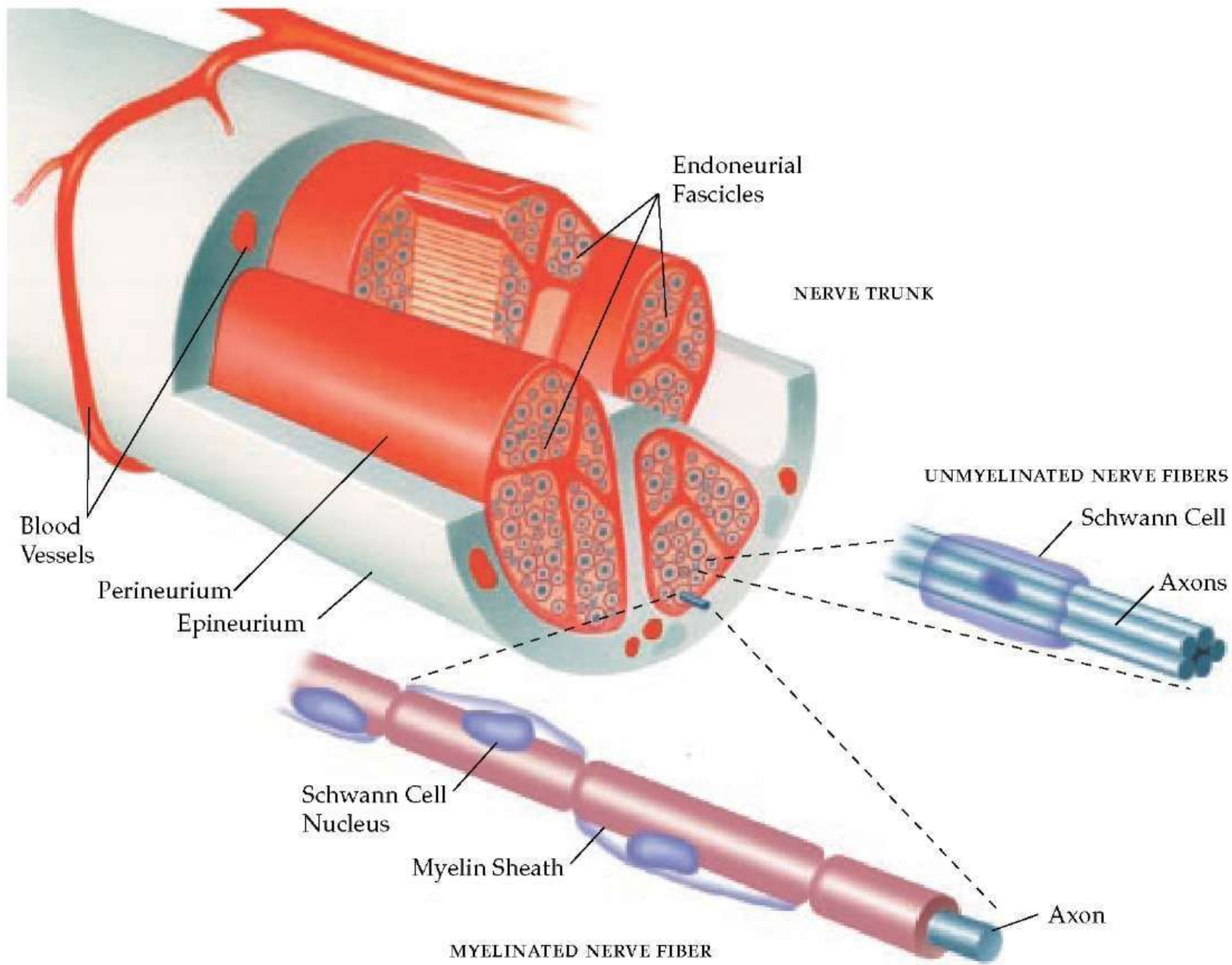

Endoneurial Fascicles

NERVE TRUNK

Blood Vessels

Perineurium

Epineurium

UNMYELINATED NERVE FIBERS

Schwann Cell

Axons

Schwann Cell Nucleus

Myelin Sheath

Axon

MYELINATED NERVE FIBER



Thank You
Thank You
Thank You!!!!

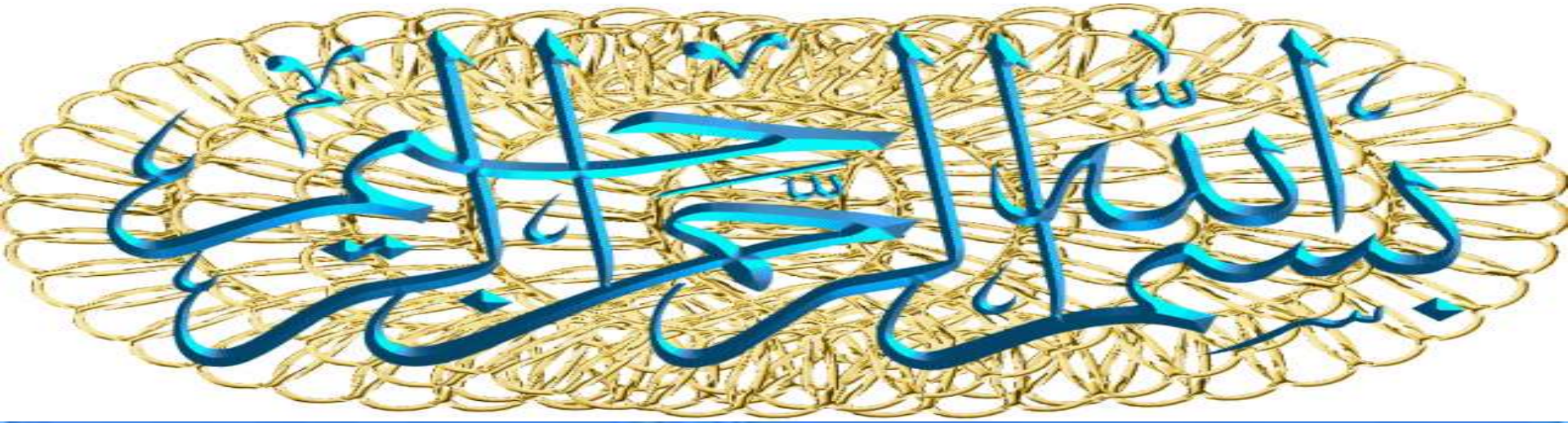

پریشان حال کی مدد

حضرت انسؓ سے روایت ہے کہ رسول اللہ صلی اللہ علیہ وسلم نے ارشاد فرمایا

جو شخص کسی پریشان حال انسان کی مدد کرے۔ اللہ تعالیٰ اُس کیلئے تہتر مغفرتیں لکھے گا جن میں سے ایک مغفرت تو اُس کے تمام کاموں کی اصلاح کیلئے کافی ہے اور بہتر قیامت کے دن اُس کیلئے درجات بن جائیں گی۔ (بیہقی، حیات المسلمین)

Anatomy and Physiology of Spinal Nerve Roots

- ⌘ Embryological developmental stages, spinal cord has same length as vertebral column. But in fully grown individual spinal cord ends as conus medullaris approximately at 1st lumbar vertebrae.
- ⌘ Nerve root for sacral region exit from point just below thoracic region, the nervous content of this spinal canal is only comprised of lumbosacral roots, this lumbosacral nerve roots within the lumbar & sacral has been suggested to resemble tail of horse called cauda equina.

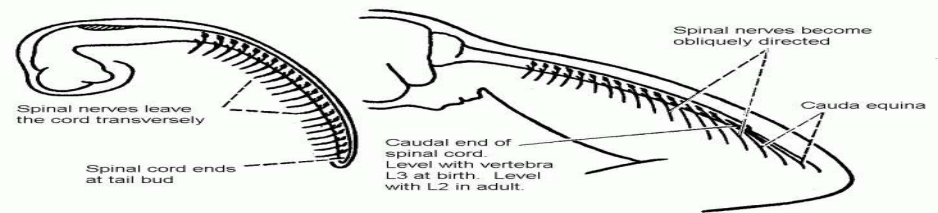

Growth of the embryonic and fetal spinal cord

(Based on a figure of R. W. Haines & A. Mohiuddin (1970) *Handbook of Human Embryology*, 4th edn. Edinburgh: Livingstone.)

⌘ Motor axons lie AHC of grey matter in spinal cord as nerve roots leave the spinal cord from ventral side so called **ventral roots**.

⌘ The other type is **sensory/dorsal roots**(roots mainly comprise of afferent axons & reach spinal cord at dorsal region of spinal cord call bodies of sensory axons **located** in swelling of caudal part of respective nerve root called dorsal root ganglion which located in/close intervertebral foramina.

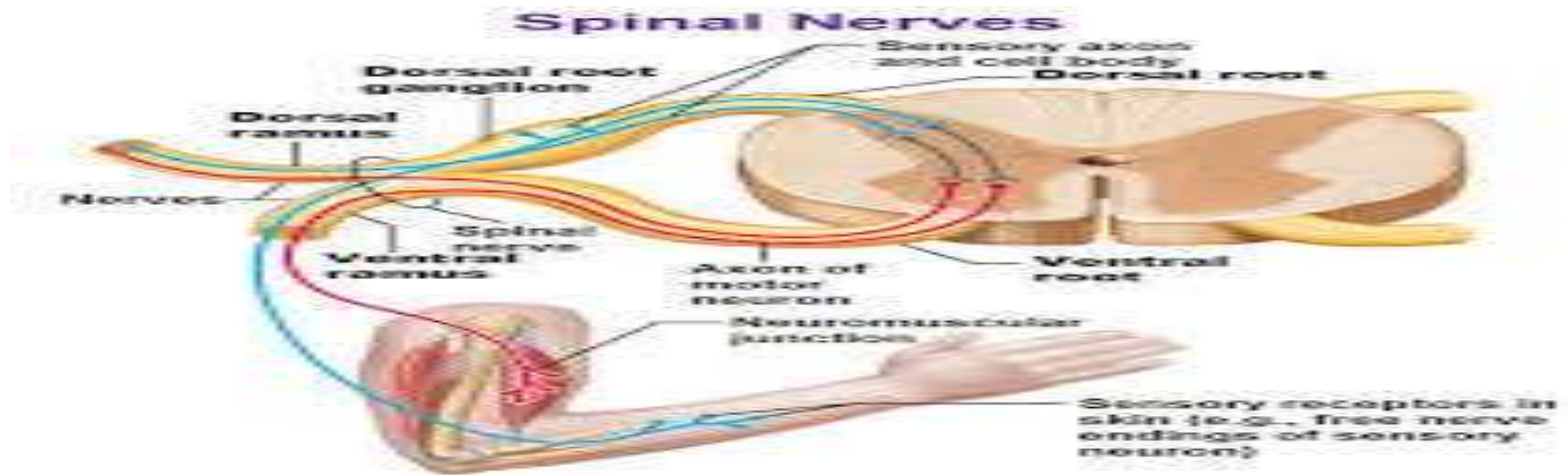

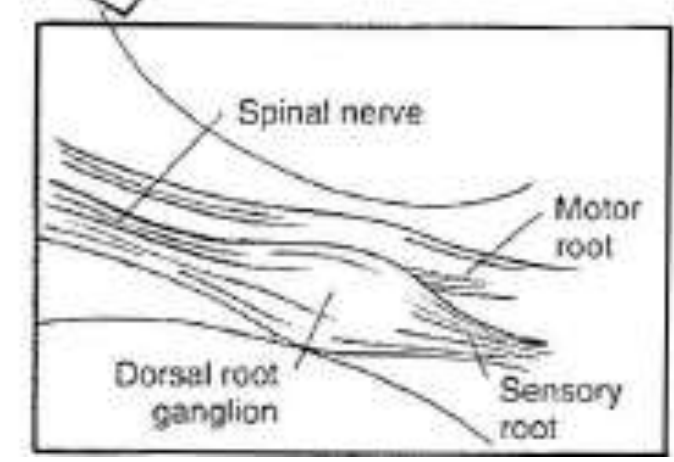
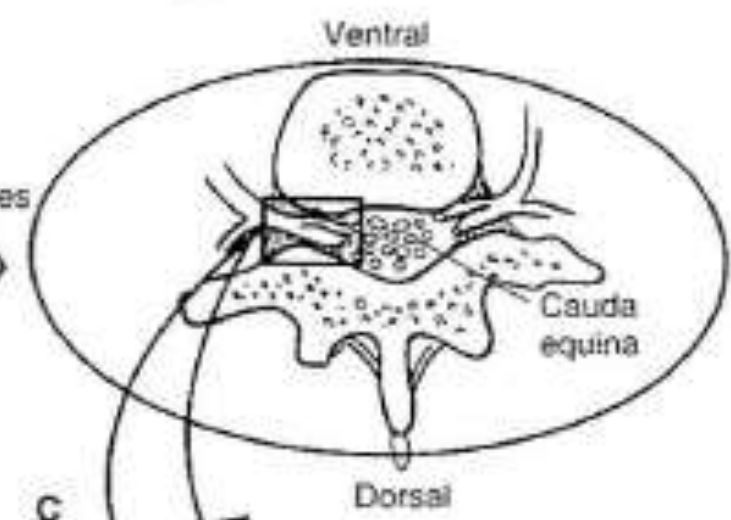
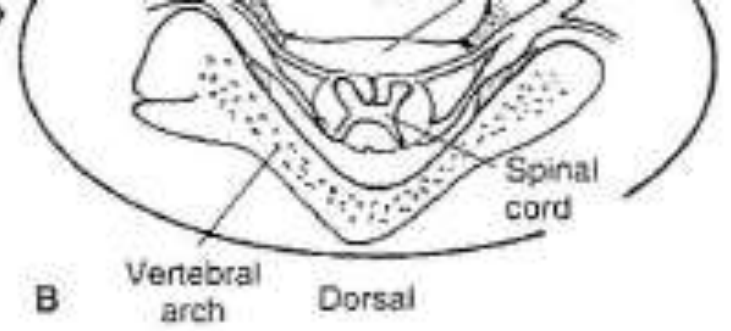
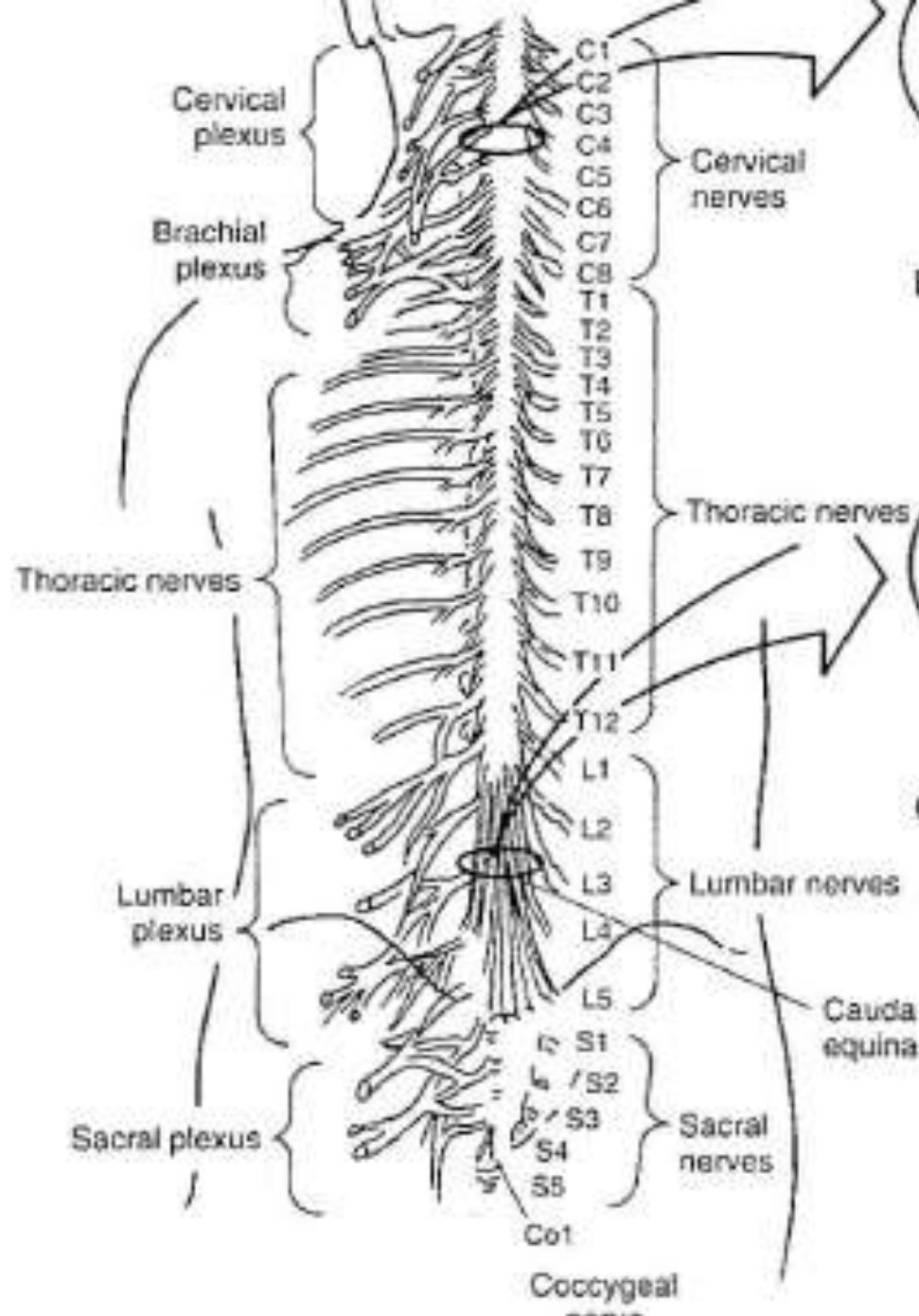

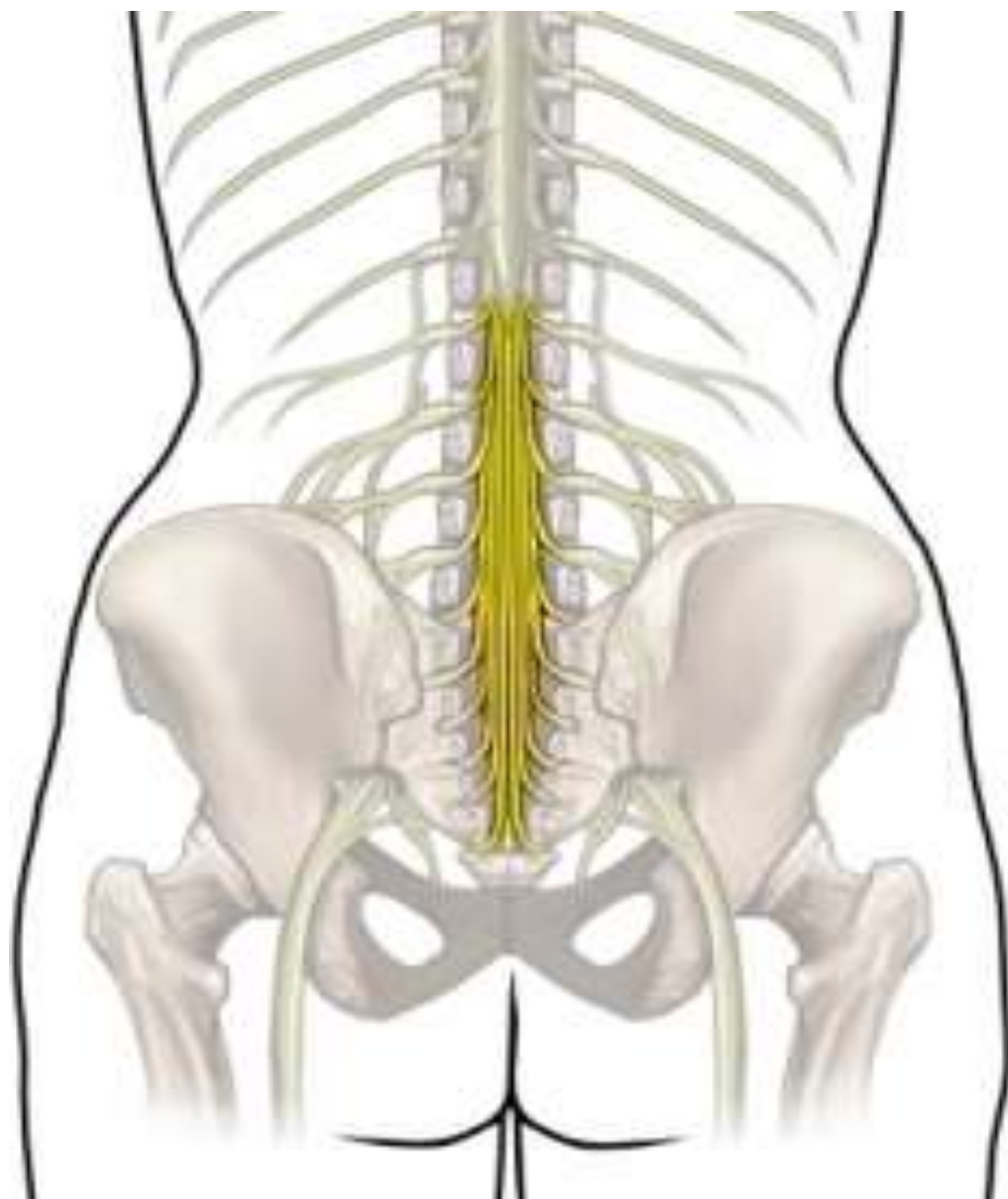

Spinal cord

Cauda equina
(horse's tail)

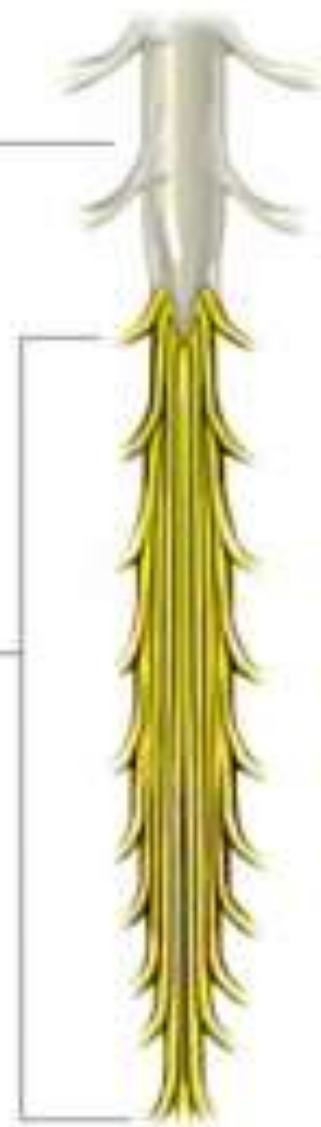

Membranous coverings of spinal nerve Roots

⌘ The axons/nerve roots in the endoneurium are separated from the cerebrospinal fluid by a thin layer of connective tissue called the **Root Sheath**, 2 to 5 cellular layers in the root sheath. **& fluid barrier.**

⌘ **Outer layers/proximal part** of root sheath similar to the **Pia cells** of the spinal cord
Distal part similar to the arachnoid cells of the **spinal Dura.**

The inner layers of root sheath resemble to **perineurium** of peripheral nerves.

Fluid barrier: The inner layers of the root sheath constitute a diffusion barrier between the endoneurium of the nerve roots and the cerebrospinal fluid, This barrier is considered to be relatively weak and may only prevent the passage of macromolecules.

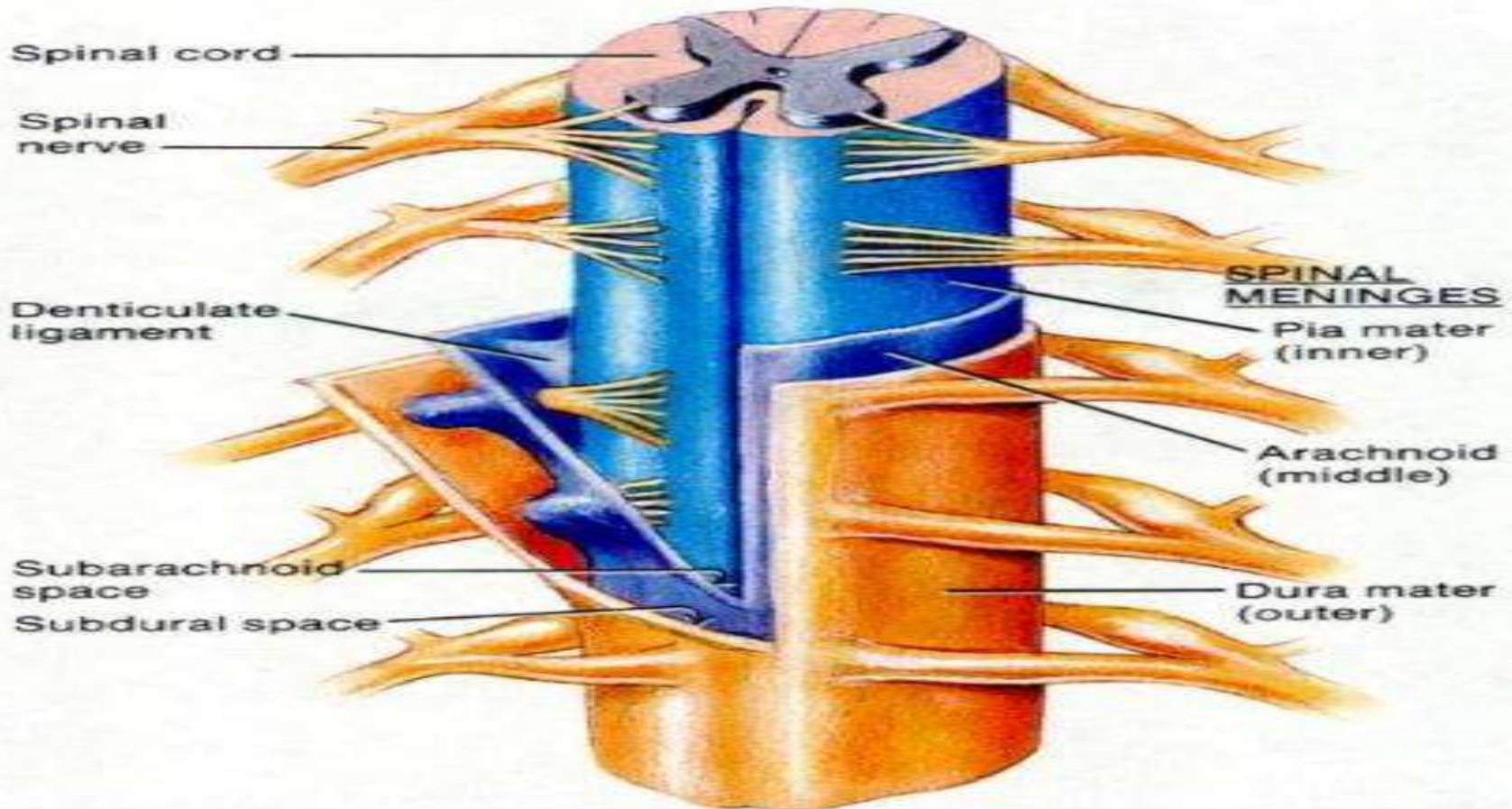

The Microvascular system of spinal nerve roots

- ⌘ **Vascularization** of the spinal cord
- ⌘ The segmental arteries generally divide into three branches when approaching the Intervertebral foramen
- ⌘ ***An anterior branch*** that supplies the posterior abdominal wall and lumbar plexus.
- ⌘ ***A posterior*** branch that supplies the paraspinal muscles and facet joints
- ⌘ ***An intermediate branch*** that supplies the contents of the spinal canal

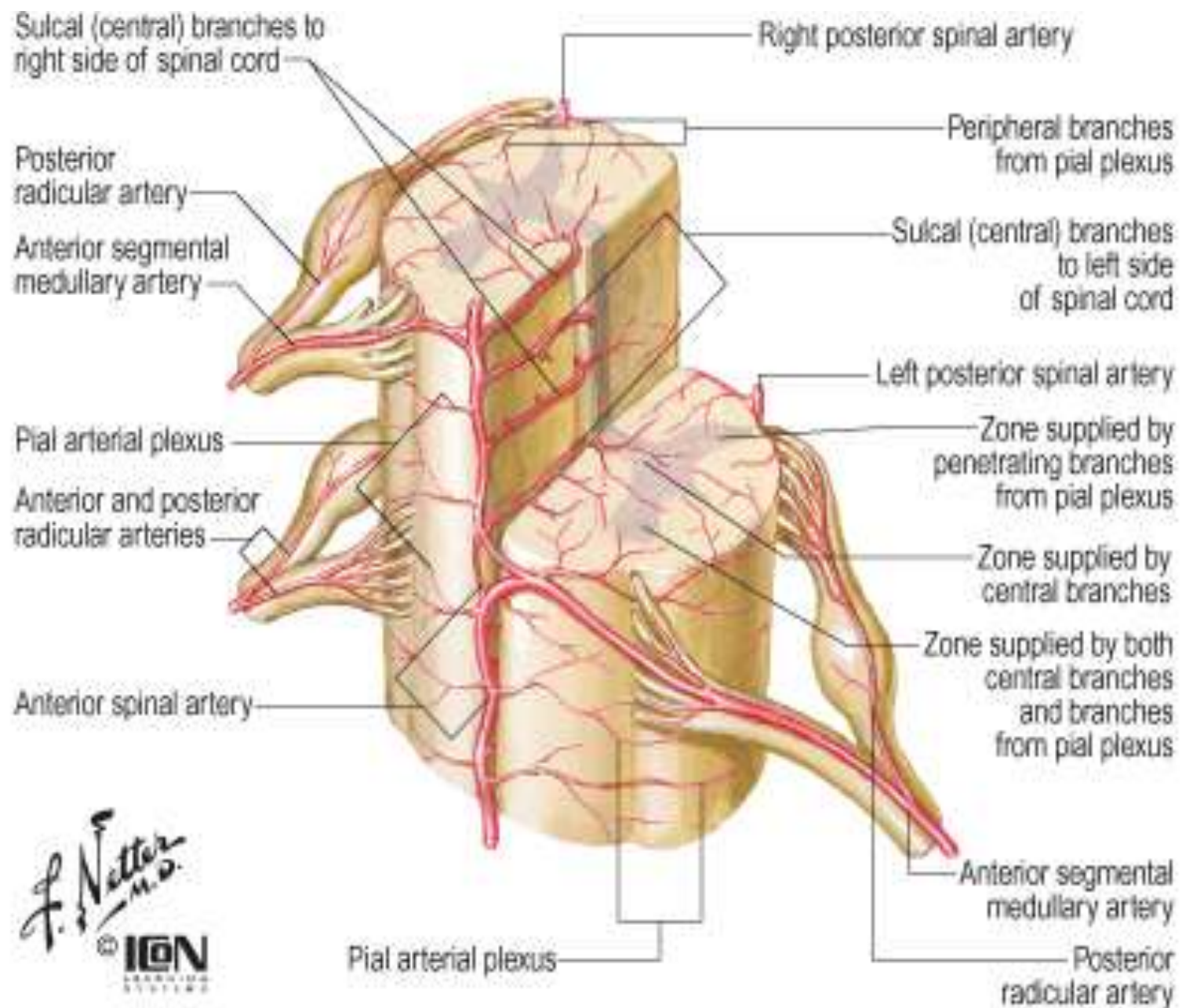

F. & N. Netter
 M.D.
 © ION
 ILLUSTRATIONS

⌘ A branch of the **intermediate** branch joins the nerve root at the level of the dorsal root ganglion

Three branches from this vessel:

⌘ one to the ventral root

⌘ One to the dorsal root

⌘ One to the vasa corona of the spinal cord (**vasa corona**. An obsolete term that formerly used for any of the arterial anastomoses that penetrate the spinal cord in a radial fashion.

⌘ **Branches of Vasa corona** of the spinal cord, called medullary arteries

⌘ Medullary arteries run parallel to the nerve roots.....no connection with network of nerve roots.

⌘ **Medullary feeder arteries** only occasionally supply the nerve roots, they have been referred to as the ***extrinsic vascular system*** of the Cauda Equina.

⌘ The vasculature of the nerve roots is formed by branches **from the intermediate branch** of the segmental artery distally and by branches from the **vasa corona** of the spinal cord proximally.

⌘ As opposed to the medullary arteries, this vascular network has been named the ***intrinsic vascular system*** of the Cauda Equina

⌘ Arteries of the intrinsic system send branches down to the deeper parts of the nerve tissue in a ***T like manner***.

Schematic presentation of some anatomical features of the intrinsic arteries of the spinal nerve roots

The arterioles within the cauda equina may be referred to either the extrinsic (1) or the intrinsic (2) vascular system. From the superficial intrinsic arterioles are branches that continue almost at right angles down between the fascicles. These vessels often run in a spiraling course, thus forming vascular "coils" (3). When reaching a specific fascicle they branch in a T-like manner, with one branch running cranially and one caudally, forming interfascicular arterioles (2b).

From these interfascicular arterioles are small branches that enter the fascicles, where they supply the endoneurial capillary networks (2c).

Arterioles of the extrinsic vascular system run outside the spinal dura (4) and have no connections with the intrinsic system by local vascular branches. The superficial intrinsic arterioles (2a) are located within the root sheath (5).

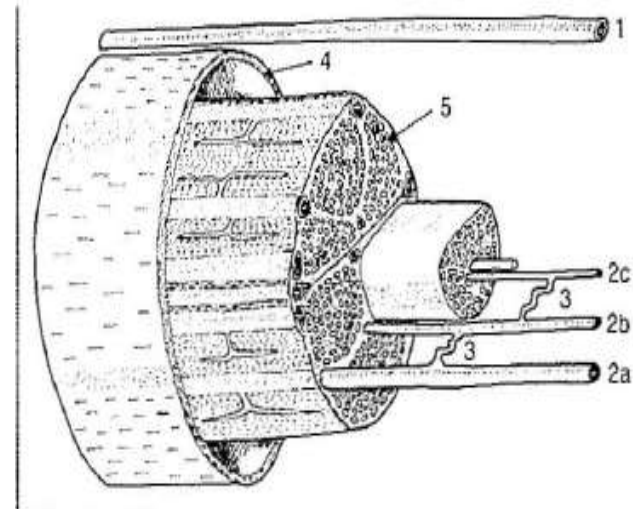



⌘ Barrier of the endoneurial capillaries in peripheral nerves called the ***Blood-nerve barrier***, which is similar to the blood-brain barrier of the central nervous system



⌘ ***but barrier is in still question if present then, Edema*** formed more easily in nerve roots

Biomechanical Behavior of Peripheral Nerves

- ⌘ External trauma to the extremities and nerve entrapment
- ⌘ There may be changes in nerve structure and function if mechanical trauma exceeds a certain degree.
- ⌘ Common modes of nerve injury are stretching and compression caused by rapid extension and crushing.

Stretching (Tensile) Injuries Of Peripheral Nerves

- ⌘ These may occur as a result of rapid extension of the nerve or by crushing. Nerves may also be damaged by chemical, thermal, and ischemic means.
- ⌘ Nerves have the ability for self-repair, but the process is slow and dependent on the severity of the injury.
- ⌘ A stretching injury may result in failure of the nerve without failure of the surrounding membranes.

⌘ If this occurs than the nerve has a pathway to follow during its regeneration.

⌘ Nerve regeneration is much more difficult if the entire nerve is damaged and retracts.

Stretching (Tensile) Injuries Of Peripheral Nerves

⌘ The maximal load that can be sustained by the median and ulnar nerves is in the range of 70 to 220 Newton (N) and 60 to 150 N, respectively.

- 
- ⌘ Initially: low load → significant elongation
 - ⌘ Elastic/linear region
 - ⌘ Disruption of endoneurial tubes & perineurium → rupture

⌘ Elongation of nerve under very small load followed by an interval in which stress and elongation show a linear relationship

⌘ As the limit of the linear region is approached, **the nerve fibers** start to rupture inside the endoneurial tubes and inside the intact perineurium.

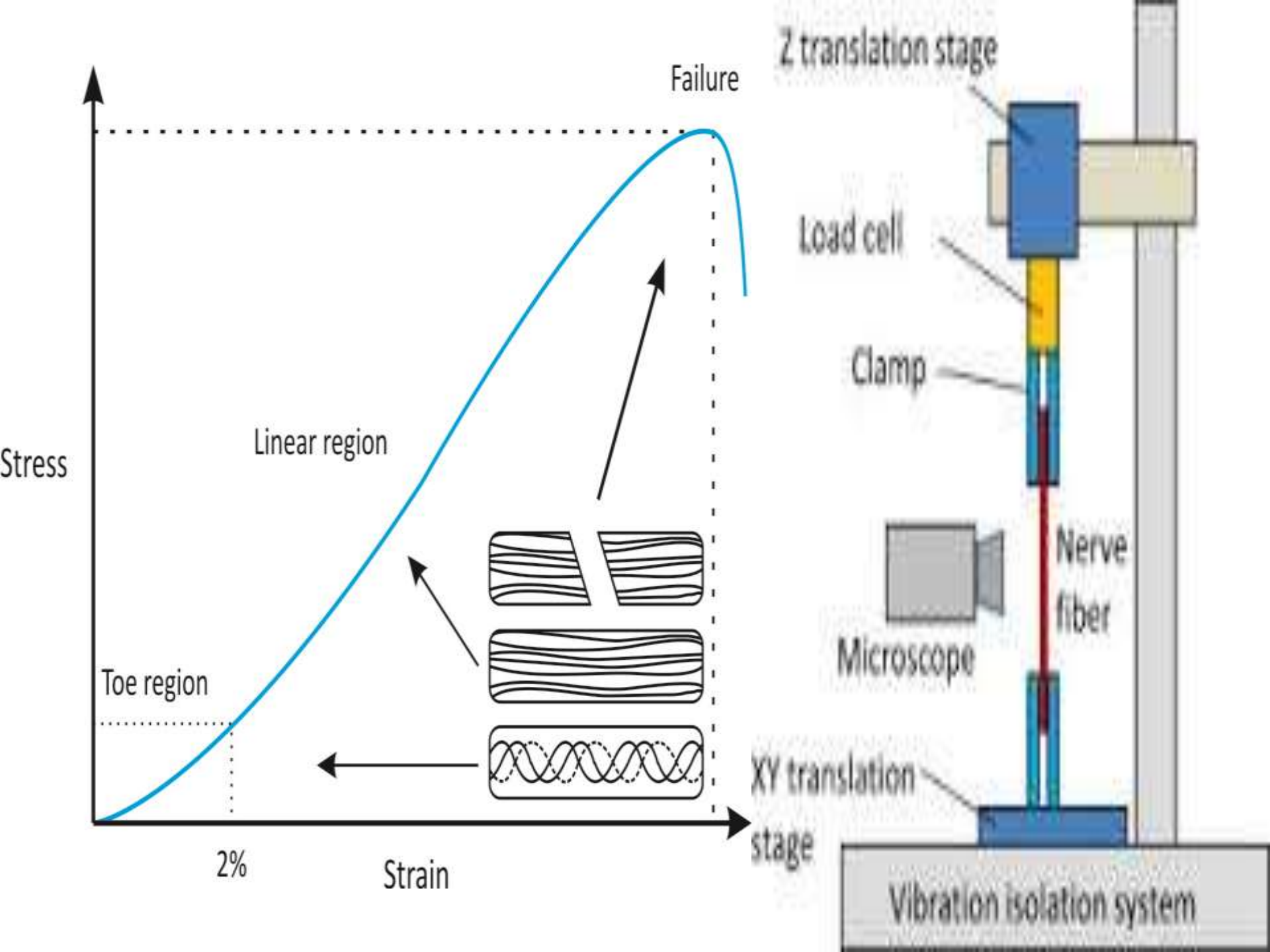

⌘ The perineurial sheaths rupture at approximately 25 to 30% elongation



- ⌘ Stretching, or tensile, injuries of peripheral nerves are usually associated with severe accidents----
→ Partial or total functional loss of some or all of the nerves in the upper extremity, and the consequent functional deficits
- ⌘ The **outcome** depends on which tissue components of the nerves are damaged as well as on the extent of the tissue injury.
- ⌘ **High-energy plexus injuries** represent an extreme type of stretching lesion caused by sudden violent trauma

⌘ **Treatment:**

- ⌘ **Suturing** of the two ends under moderate tension (Moderate tension necessary to bring both ends together and to maintain blood supply)
- ⌘ **The moderate, gradual tension** applied to the nerve in these cases may cause elongation stretch and angulate local feeding vessels help in nerve healing.
- ⌘ Attempts to suture the nerve together may cause increased tension in the nerve, which may lead to blood flow occlusion and inhibition of nerve regeneration.
- ⌘ **Note: Complete cessation** of all blood flow in the nerve usually occurs at approximately 15% elongation

**Schematic representation of a peripheral nerve and its blood supply at three stages during stretching.
Stage III: 15% elongation**

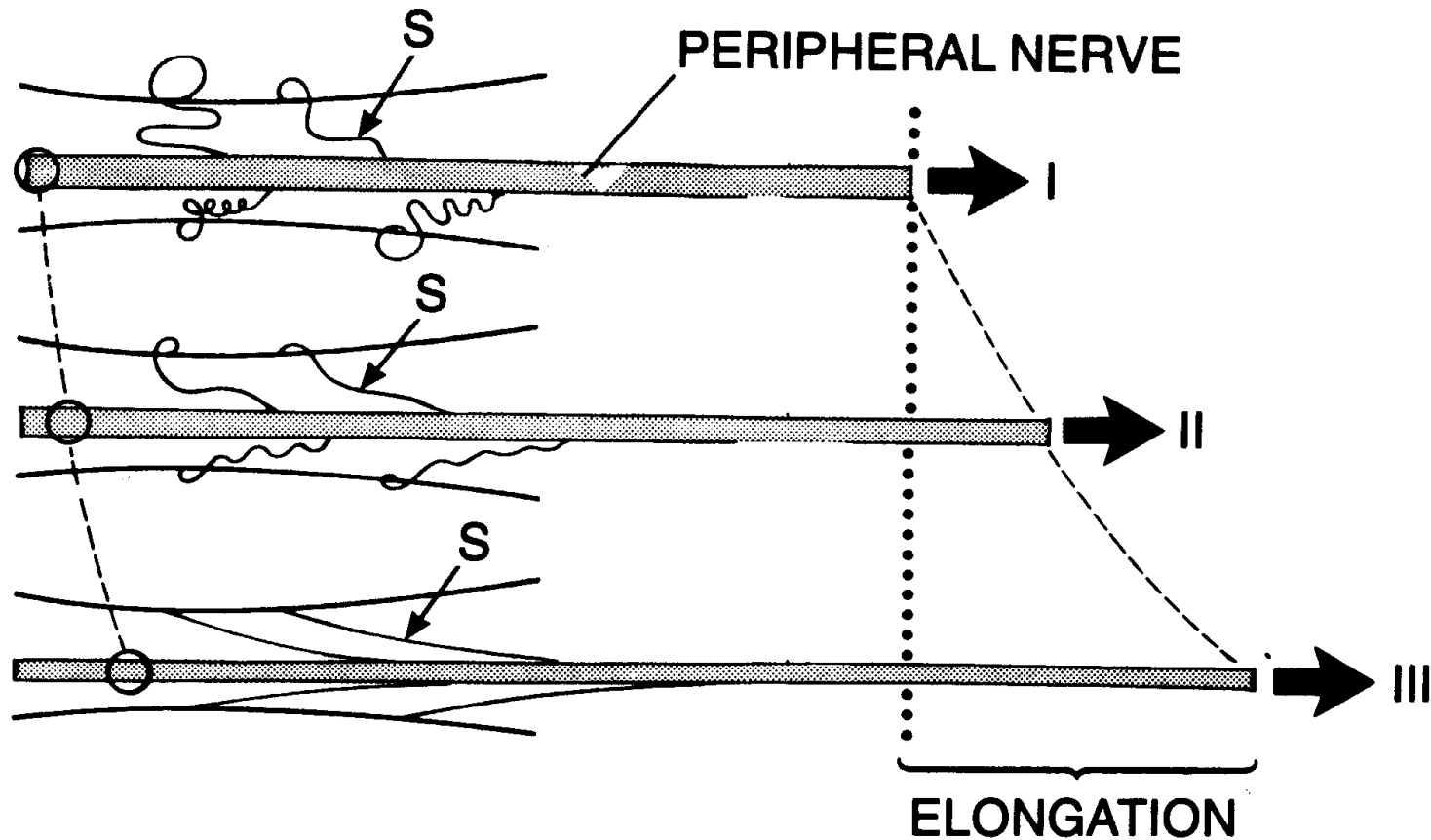

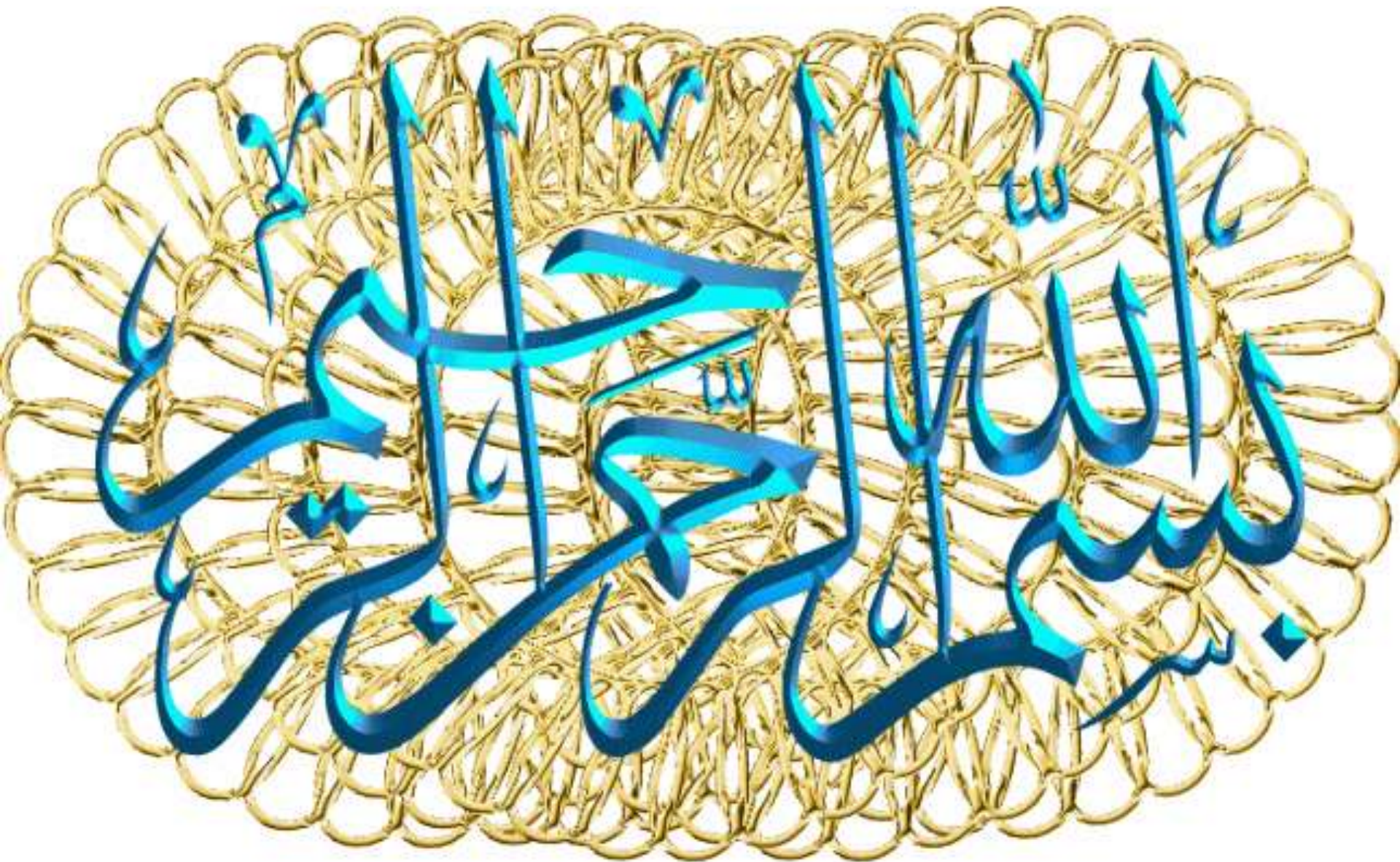

Compression Injuries Of Peripheral Nerves

- ⌘ Compression of a nerve can induce symptoms such as numbness, pain, and muscle weakness.
- ⌘ Depend on: Pressure level and mode of compression



Compression Injuries Of Peripheral Nerves

- ⌘ Nerves are very sensitive to oxygen concentrations and it appears that compression injuries may act to inhibit oxygen availability.
- ⌘ Intermittent compressive loads may lead to scar formation which may inhibit blood flow and oxygen transport.
- ⌘ Pressures of 30 mm of mercury 72 for several hours may lead to nerve impairment.

Compression Injuries Of Peripheral Nerves

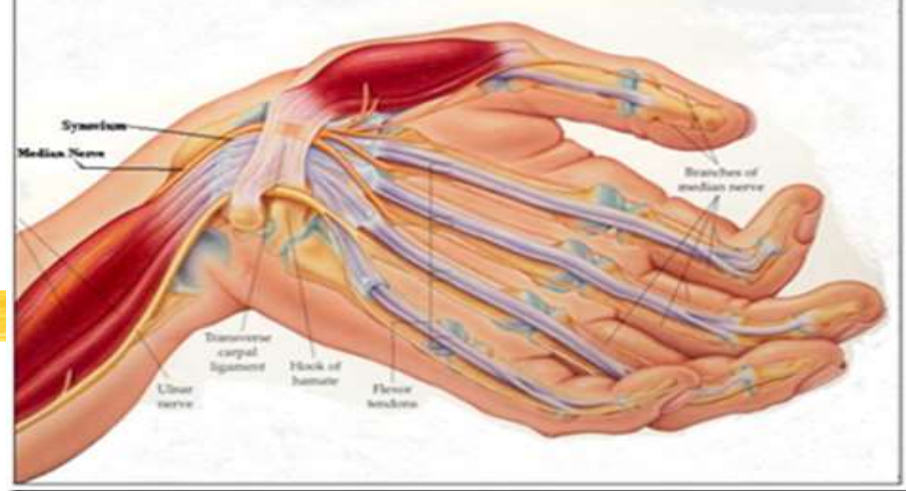

- ⌘ At ***30 mm Hg*** of local compression, functional changes may occur in the nerve, and its viability may be increased during prolonged compression (4 to 6 hours) at this pressure level..(impaired blood flow.)
- ⌘ Corresponding pressure levels (approximately 32 mm Hg) were recorded close to the median nerve in the carpal tunnel in patients with ***carpal tunnel syndrome***

⌘ long-standing compression lead to depletion of axonally transported signals distal to the compression site. (Changes in the axonal transport systems, depend on Magnitude of **applied pressure** and **severity of the induced compression lesion**.)

⌘ Such blockage cause axon More susceptible to additional compression distally the so-called ***double crush syndrome***.

⌘ Slightly higher pressure (***80 mm Hg, for example***) causes complete cessation of Intraneural blood flow; the nerve in the locally compressed segment becomes completely ischemic

Compression Injuries Of Peripheral Nerves

Mode of Pressure Application

- ⌘ Mode of pressure application is also of major significance
- ⌘ Direct compression of a nerve at 400 mm Hg by means of a small inflatable cuff around the nerve induces a more severe nerve injury **than does indirect** compression of the nerve at 1000 mm Hg via a tourniquet applied around the extremity.

Compression Injuries Of Peripheral Nerves

Mechanical Aspects of Nerve Compression

- ⌘ Experiments on baboon's nerve by tourniquet compression.
- ⌘ "Edge effect" a specific lesion was induced in the nerve fibers at both edges of the compressed nerve segment
- ⌘ Nodes of Ranvier were displaced toward the non compressed parts of the nerve.

- ⌘ Nerve fibers in center not effected (In center hydrostatic pressure high so spare the nerve fibers)
- ⌘ Compression lesion of a nerve first affects the *large fibers* carrying motor function while the *thin fibers* carrying pain sensation) are often preserved
- ⌘ *Intraneural blood vessels* have also been shown to be injured at the edges of the compressed segment

⌘ Consequences of the pressure gradient= higher at the edges



⌘ Effect of a given pressure depends on the way in which it is applied, its magnitude and duration.

⌘ Two basic types of pressure applications

⌘ **1:Uniform pressure** applied around the entire circumference of a longitudinal segment or a nerve or extremity.

⌘ 2:Radial pressure that is applied by the common pneumatic tourniquet.

⌘ 2nd experiment= Nerve is compressed laterally

⌘ When a nerve or extremity is placed between two parallel flat rigid surfaces that moved toward each other squeezing the nerve, damage nerve as whole resulting in denervation of distal segment of damaged nerve. Symptoms produced weakness, paresis or paralysis of distal innervated muscles depends on severity of damage.

⌘ Example: sudden blow by a rigid object squeezes a nerve against the surface of an underlying bone

Duration of Pressure Versus Pressure Level

- ⌘ Mechanical factors are relatively more important at higher than at lower pressures.
- ⌘ Duration is more imp than pressure level,-
→ indicate High pressure has to act for a **certain period of time** for injury to occur.
- ⌘ **Ischemia** plays a dominant role in longer duration compression.
- ⌘ **Time factors most imp**.....
- ⌘ Compression at **400 mm** Hg causes a much more severe nerve injury after 2 hours than after 15 minutes.

Compression Injuries Of Peripheral Nerves

- ⌘ The ability to recover from such injury is dependent on the damage incurred, which depends on the nerve, type of compression, duration of compression, and the type of deformation created.
- ⌘ After an injury in which the membranes remain intact, the distal parts of the nerve degenerate and are resorbed by macrophages.

Compression Injuries Of Peripheral Nerves

- ⌘ During the first week following injury Schwann cells proliferate and proximal axons start sending out a great number of sprouts which grow toward the distal end.
- ⌘ The rate of axonal growth is about 1-3 mm per day. Repair of an injury in which the membranes are disrupted is less well organized.
- ⌘ Regenerating axons often do not reinnervate the same organs and thus there is some central reprocessing that must occur to regain proper motor control.
- ⌘ Nerve regeneration is greatly influenced by biochemical and biomechanical factor

Biomechanical Behavior of Spinal Nerve Roots

⌘ **Characteristics of nerve roots:**

- ⌘ The nerve roots in the thecal sac lack **epineurium and perineurium**, but under tensile loading they exhibit both elasticity and tensile strength.
- ⌘ Ultimate load for **ventral spinal nerve** roots from the thecal sac is between 2 and 22 N
- ⌘ For **dorsal root** is 5-33 N
- ⌘ Damage occur above than this load.

- ⌘ The values of ultimate load are approximately **five times higher** for the foraminal segment of the spinal nerve roots(nerve) than for the intrathecal portion of the same nerve roots under tensile loading.
- ⌘ Nerve roots in the spine are **not static structures, they had** Capacity to glide during movement.
- ⌘ **Disc herniation and/or Foraminal stenosis (main two causes for nerve root compression)**. can impair the gliding capacity of the nerve roots --→damage of nerve root

⌘ **Repeated "microstretching"** injuries of the nerve roots occur even during normal spinal movements leads to Further tissue irritation in the nerve root components

⌘ was studied by:

⌘ **Cadaver experiments**= Needle pressure transducer and a Calibrator (tuned)

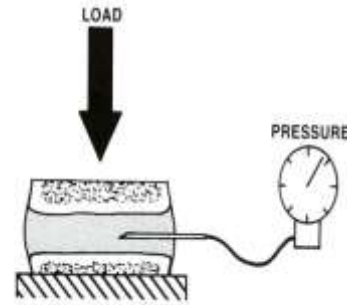

☑ Introduced into nucleus pulposus/ surrounding soft tissues of cadaveric functional unit to study pressure on discs or nerve roots.

⌘ (It was found that straight leg raising moved the nerve roots at the level of the Intervertebral foramina approximately 2 to 5 mm increase pressure on nerve roots causing repetitive trauma damage to root.

⌘ Symptoms induced by nerve root deformation in association with **disc herniation & spinal stenosis** and resulting in radiating pain. (sciatica= compression of sciatic nerve roots compression)

⌘ **Disc herniation**, only one nerve root is usually compressed.

⌘ Sciatic pain is relieved after chemonucleolysis(chymopapain) disc degeneration,(degrade & remove unrepaired discs material) otherwise progresses over time and compress nerve roots continuously.

**Lumbar Disc
Herniation**

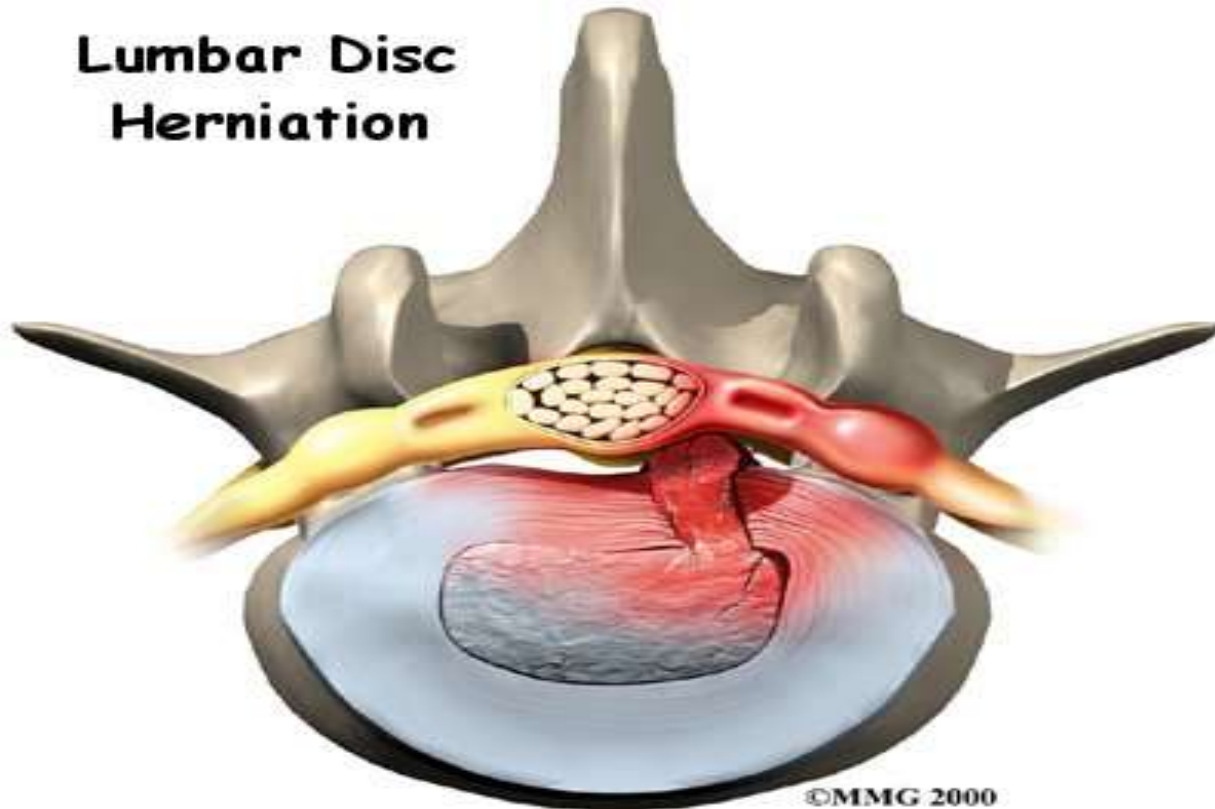

©MMG 2000

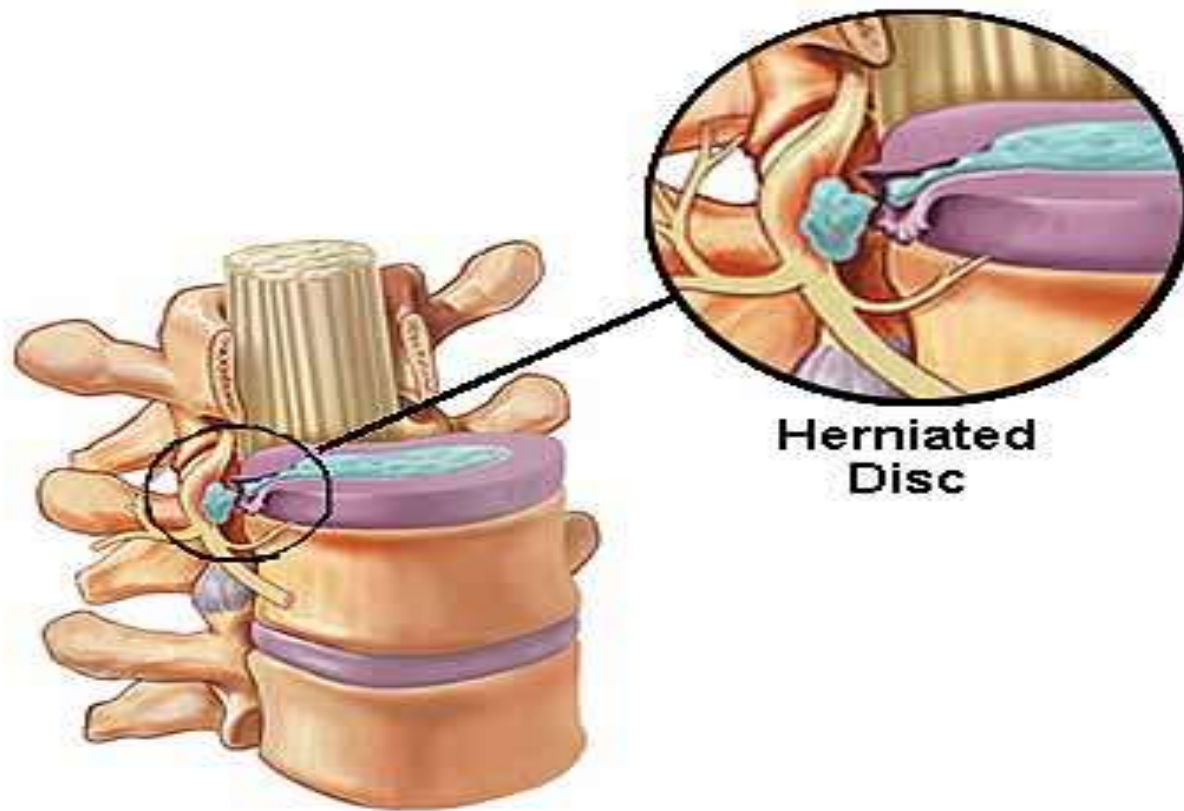

**Herniated
Disc**

Four stages to a disc herniation

Degeneration



Prolapse



Extrusion



Sequestration



SPINE CONDITIONS



SCIATICA

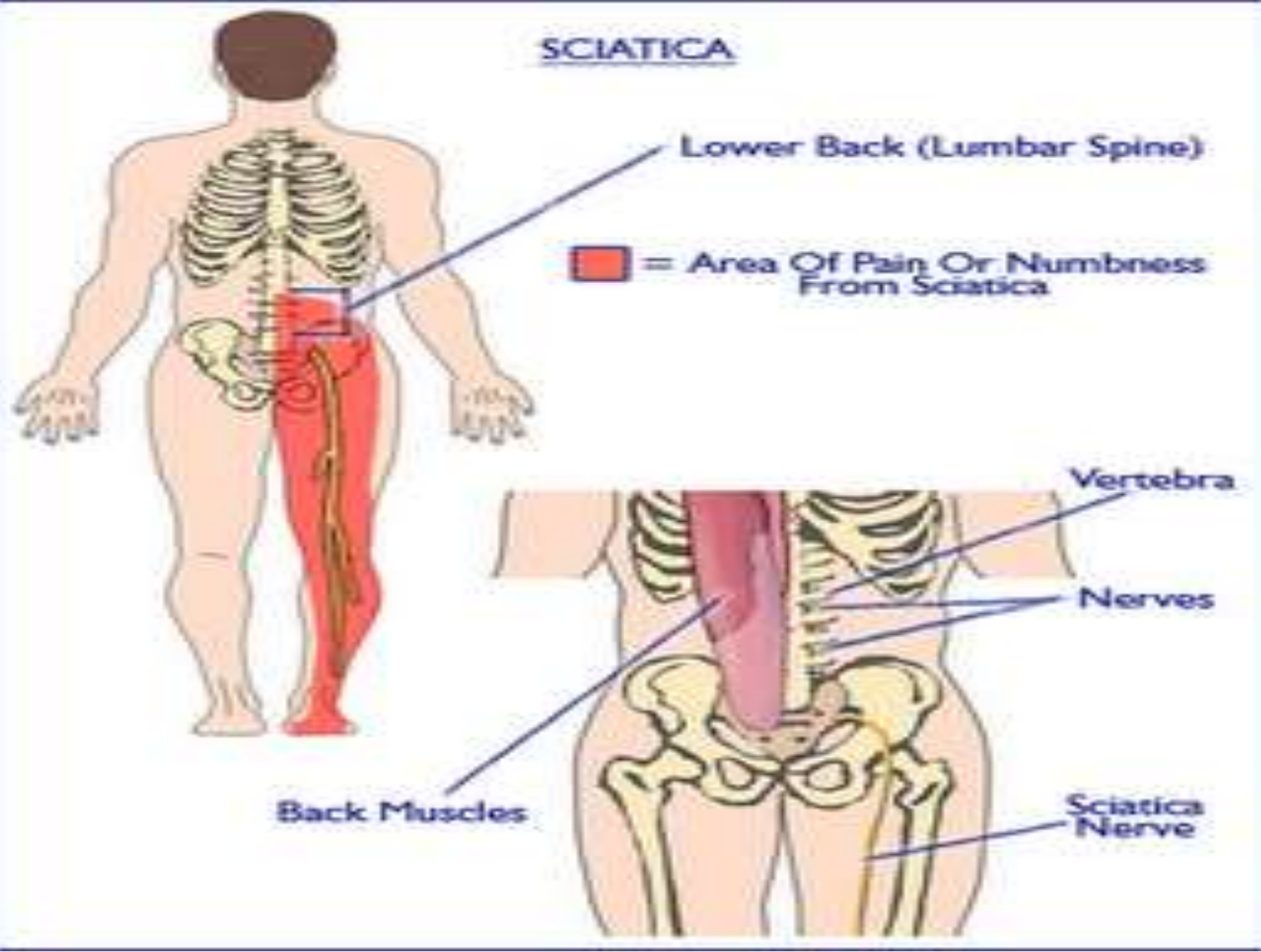

Lower Back (Lumbar Spine)

■ = Area Of Pain Or Numbness From Sciatica

Vertebra

Nerves

Back Muscles

Sciatica Nerve

⌘ spinal foramina stenosis:

⌘ Stenosis causes compression on peripheral nerve and produce radiating pain, parathesia or numbness

⌘ the mechanics or nerve root compression are completely different.

⌘ The pressure is applied circumferentially

around the nerve roots in the Cauda Equina at a **slow, gradual rate** shows different symptoms as compare to pressure more laterally (**almost same manner as for nerves**). Nerve roots centrally within the Cauda Equina differ completely from the nerve roots located more laterally, close to the discs.

⌘ **In central lesion: Symptoms** of spinal cord damage, saddle anesthesia, or loss of bowel and bladder control.

Wallerian degeneration

- ⌘ The degenerative changes the distal segment of a peripheral nerve fiber (axon and myelin) occur when its continuity with its cell body is interrupted by a focal lesion. OR
- ⌘ A process that results when a nerve fiber is cut or crushed and the part of the axon distal to the injury degenerates.
- ⌘ This is also known as **anterograde** or **orthograde degeneration**.
- ⌘ Wallerian degeneration occurs after axonal injury in both the peripheral nervous system (PNS) and central nervous system (CNS).



Thank You
Thank You
Thank You!!!!

SHAY